

R3G210-AA73-01 ebmpapst Datasheet
 sales@fansco.com
 www.fansco.com

Limited partnership · Headquarters Muldingen
 County court Stuttgart · HRA 590344

General partner Elektrobau Muldingen GmbH · Headquarters Muldingen
 County court Stuttgart · HRB 590142

Nominal data

Type	R3G210-AA73-01	
Motor	M3G074-CF	
Phase		1~
Nominal voltage	VAC	230
Frequency	Hz	50/60
Type of data definition		fa
Speed (rpm)	min ⁻¹	3050
Power input	W	176
Current draw	A	1.4
Max. ambient temperature	°C	60

ml = Max. load · me = Max. efficiency · fa = Running at free air · cs = Customer specs · cu = Customer unit
 Subject to alterations



Technical features

Mass	3.4 kg
Size	210 mm
Surface of rotor	Thick layer passivated
Material of impeller	Sheet steel, rust-resistant
Direction of rotation	Clockwise, seen on rotor
Type of protection	IP 44; Depending on installation and position as per EN 60034-5
Insulation class	"B"
Humidity (F)/environmental protection class (H)	F3-1
Max. permissible ambient motor temp. (transp./ storage)	+ 80 °C
Min. permissible ambient motor temp. (transp./storage)	- 40 °C
Mounting position	Shaft horizontal or rotor on bottom; rotor on top on request
Condensate discharge holes	Rotor-side
Operation mode	S1
Motor bearing	Ball bearing
Technical features	<ul style="list-style-type: none"> - Output 10 VDC, max. 1.1 mA - Tach output - Output limit - Motor current limit - Soft start - Control input 0-10 VDC / PWM - Control interface with SELV potential safely disconnected from the mains - Over-temperature protected electronics / motor
EMC interference immunity	Acc. to EN 61000-6-2 (industrial environment)
EMC interference emission	Acc. to EN 61000-6-4 (industrial environment)
Touch current acc. IEC 60990 (measuring network Fig. 4, TN system)	<= 3.5 mA
Motor protection	Thermal overload protector (TOP) wired internally
Cable exit	Variable
Protection class	I (if protective earth is connected by customer)
Product conforming to standard	EN 60335-1; CE
Approval	EAC

Product drawing

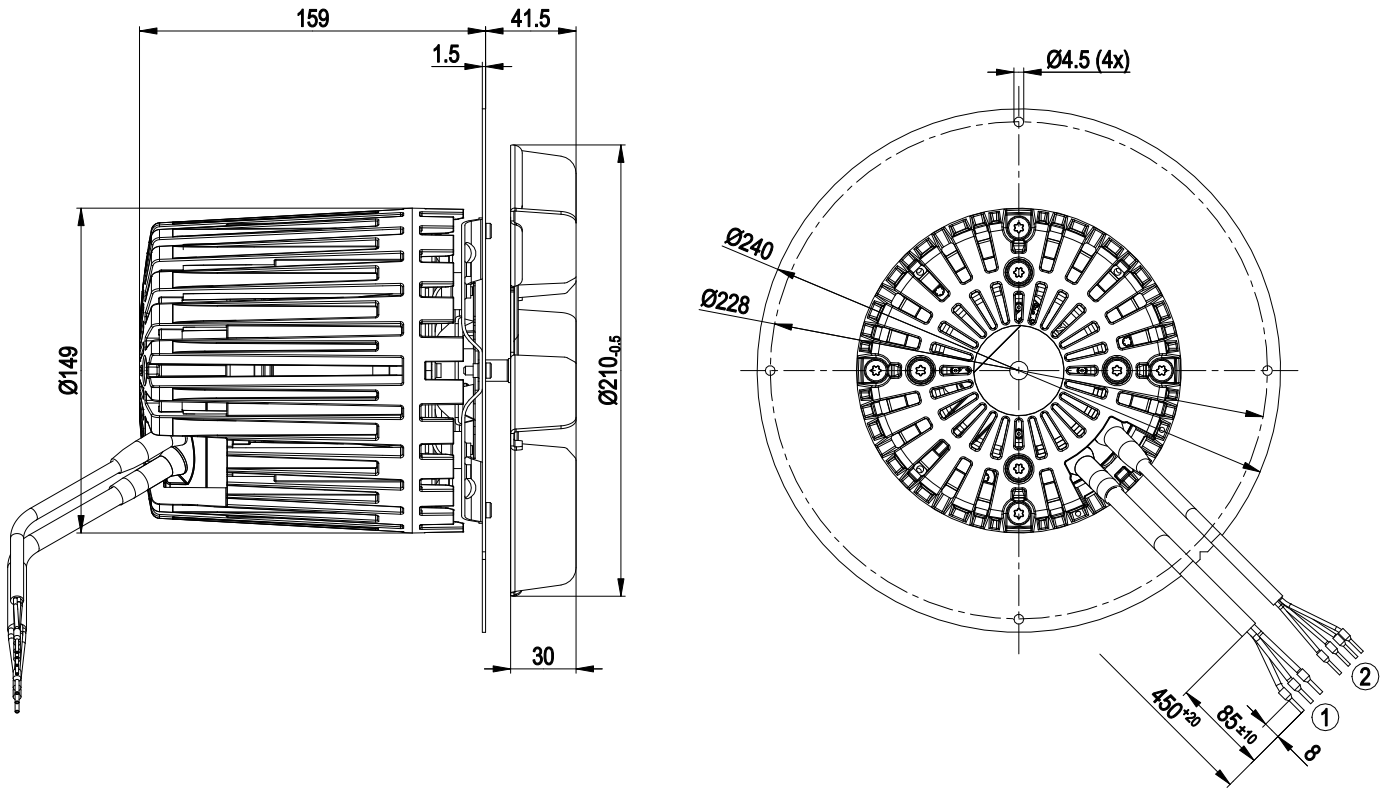

- 1 Connection line PVC AWG18, 3x crimped core-end sleeves
- 2 Connection line PVC AWG22, 4x crimped core-end sleeves

Connection screen

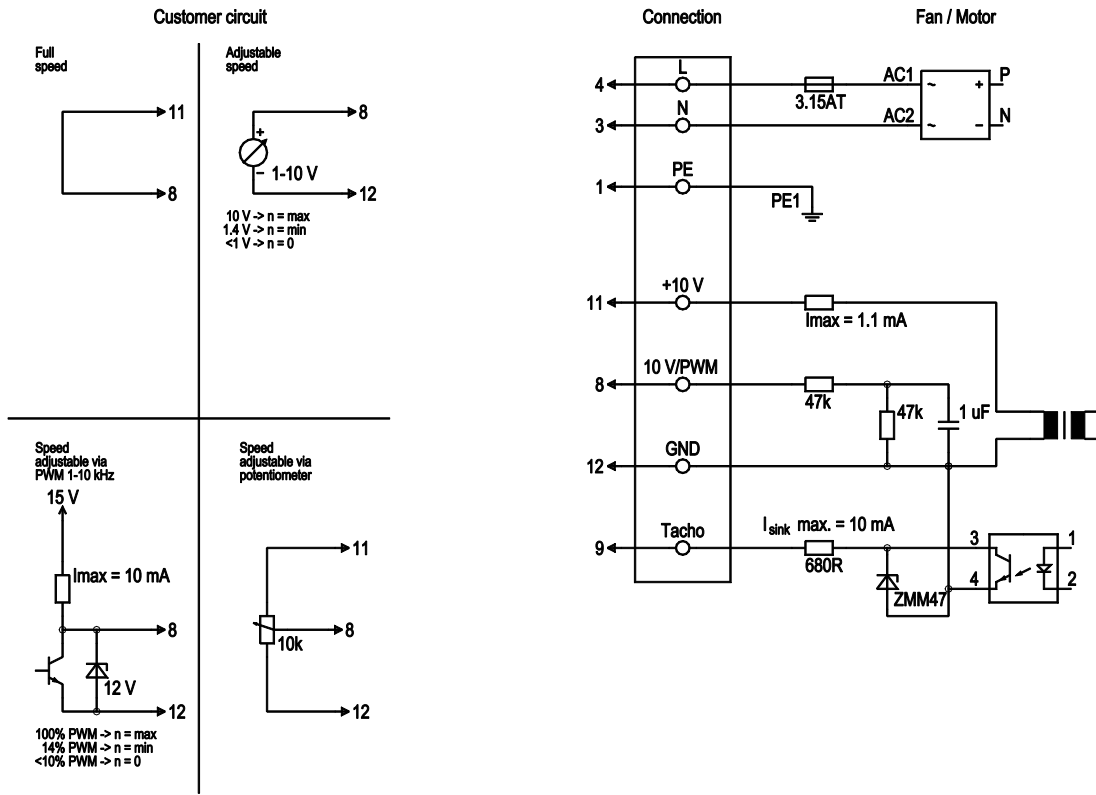

No.	Conn.	Designation	Colour	Function / assignment
	4	L	black	Power supply 230 VAC, 50-60 Hz, see type plate for voltage range
	3	N	blue	Neutral conductor
	1	PE	green/yellow	Protective earth
	8	0-10 V PWM	yellow	Control input 0-10 V or PWM, electrically isolated
	9	Tach	white	Tach output: Open collector, 1 pulse per revolution, electrically isolated, I _{sink} max = 10 mA
	11	10V / max 1.1 mA	red	Voltage output 10 V / max. 1.1 mA, electrically isolated
	12	GND	blue	GND connection for control interface

Charts: Air flow 50 Hz

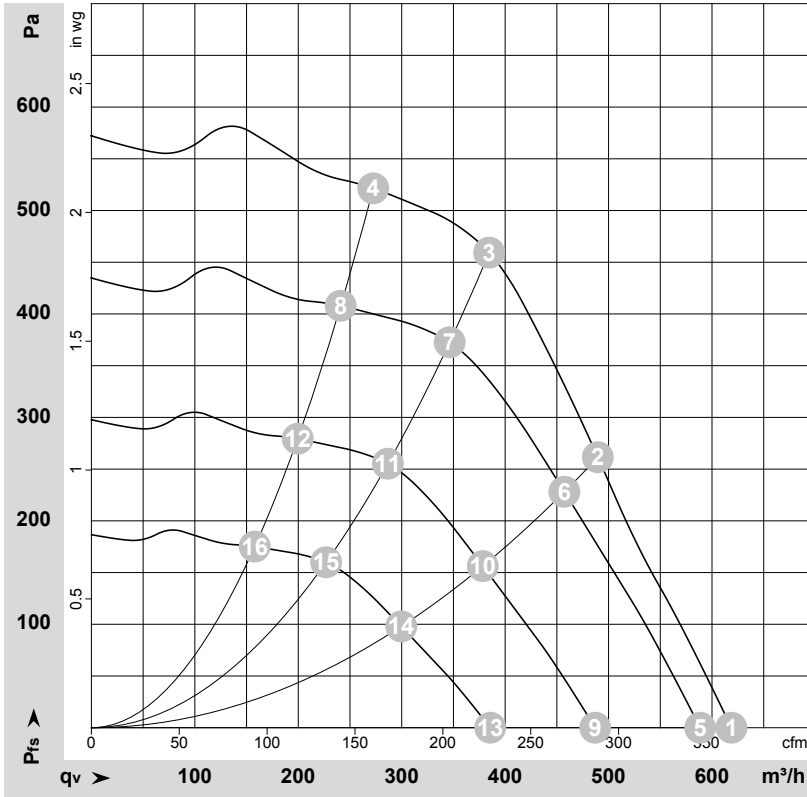

$\rho = 1.15 \text{ kg/m}^3 \pm 2 \%$

Measurement: LU-166312-1

Air performance measured as per ISO 5801 Installation category A. For detailed information on the measuring set-up, please contact ebmpapst. Suction-side noise levels: LwA measured as per ISO 13347 / LpA measured with 1m distance to fan axis. The values given are valid under the measuring conditions mentioned above and may vary according to the actual installation situation. With any deviation from the standard set-up, the specific values have to be checked and reviewed with the unit installed.

Measured values

	Conn.	U	f	n	P _{ed}	I	q _v	P _{fs}	q _v	P _{fs}
		V	Hz	min ⁻¹	W	A	m ³ /h	Pa	cfm	inH2O
1	Y	230	50	3050	176	1.40	620	0	365	0.00
2	Y	230	50	3105	176	1.40	490	260	290	1.04
3	Y	230	50	3220	164	1.33	385	460	225	1.85
4	Y	230	50	3280	145	1.19	270	520	160	2.09
5	Y	230	50	2900	152	1.21	590	0	345	0.00
6	Y	230	50	2900	143	1.15	455	228	270	0.92
7	Y	230	50	2900	120	0.97	345	374	205	1.50
8	Y	230	50	2900	100	0.82	240	408	140	1.64
9	Y	230	50	2400	86	0.69	485	0	285	0.00
10	Y	230	50	2400	81	0.65	380	156	220	0.63
11	Y	230	50	2400	68	0.55	285	256	170	1.03
12	Y	230	50	2400	57	0.47	200	280	115	1.12
13	Y	230	50	1900	43	0.34	385	0	225	0.00
14	Y	230	50	1900	40	0.32	300	98	175	0.39
15	Y	230	50	1900	34	0.27	225	160	135	0.64
16	Y	230	50	1900	28	0.23	160	175	95	0.70

Conn. = Connection · U = Supply voltage · f = Frequency · n = Speed (rpm) · P_{ed} = Power input · I = Current draw · q_v = Air flow · p_{fs} = Pressure increase

