

EC centrifugal fan - RadiCal

backward-curved, single-intake

for rail applications

R3G190-RY87-P2 ebmpapst Datasheet

sales@fansco.com

www.fansco.com

Limited partnership · Headquarters Muldingen

Amtsgericht (court of registration) Stuttgart · HRA 590344

General partner Elektrobau Muldingen GmbH · Headquarters Muldingen

Amtsgericht (court of registration) Stuttgart · HRB 590142

Nominal data

Type	R3G190-RY87-P2	
Motor	M3G074-CF	
Nominal voltage	VDC	80
Nominal voltage range	VDC	56 .. 100
Method of obtaining data		ml
Speed (rpm)	min ⁻¹	4800
Power consumption	W	240
Current draw	A	3.0
Min. ambient temperature	°C	-40
Max. ambient temperature	°C	60

ml = Max. load · me = Max. efficiency · fa = Free air · cs = Customer specification · ce = Customer equipment
Subject to change



Technical description

Weight	2.08 kg
Size	190 mm
Motor size	74
Electronics housing material	Die-cast aluminum, painted black
Impeller material	PA plastic, sheet-metal plate painted black
Number of blades	7
Direction of rotation	Clockwise, viewed toward rotor
Degree of protection	Customer-specific; IP 6K9K
Insulation class	"B"
Moisture (F) / Environmental (H) protection class	H3
Max. permitted ambient temp. for motor (transport/storage)	+80 °C
Min. permitted ambient temp. for motor (transport/storage)	-40 °C
Installation position	Any
Condensation drainage holes	None, open rotor
Mode	S1
Motor bearing	Ball bearing; (sealed)
Technical features	<ul style="list-style-type: none"> - Output 10 VDC, max. 10 mA - Alarm relay - Run monitoring - Power limiter - Motor current limitation - RS-485 MODBUS-RTU - Soft start - EEPROM write cycles: 100,000 maximum - Control input 0-10 VDC / PWM - Control interface with SELV potential safely disconnected from the mains - Overvoltage detection - Thermal overload protection for electronics - Line undervoltage detection - Reverse polarity protection
EMC regulations	According to EN 50121-3-2
Motor protection	Electronic motor protection
With cable	Lateral
Protection class assignment	<p>I; If a protective earth is connected by the customer</p> <p>This component for installation may have several local protection classes. This information relates to this component's basic design.</p> <p>The final protection class is based on the component's intended installation and connection.</p>
Conformity with standards	EN 45545-2, HL3: 2013 + A1:2015; EN 50155: 2008; EN 61373, Cat. 1B: 2010; CE
Approval	EAC
Comment	<p>If voltage (e.g. 230 VAC) is passed through the alarm relay, the SELV signal wires lose their property of reinforced insulation, meaning they then have only basic insulation</p> <p>The SELV property (reinforced insulation) is not lost when voltages of up to 110 VDC are passed through the alarm relay.</p>

EC centrifugal fan - RadiCal

backward-curved, single-intake

for rail applications

Product drawing

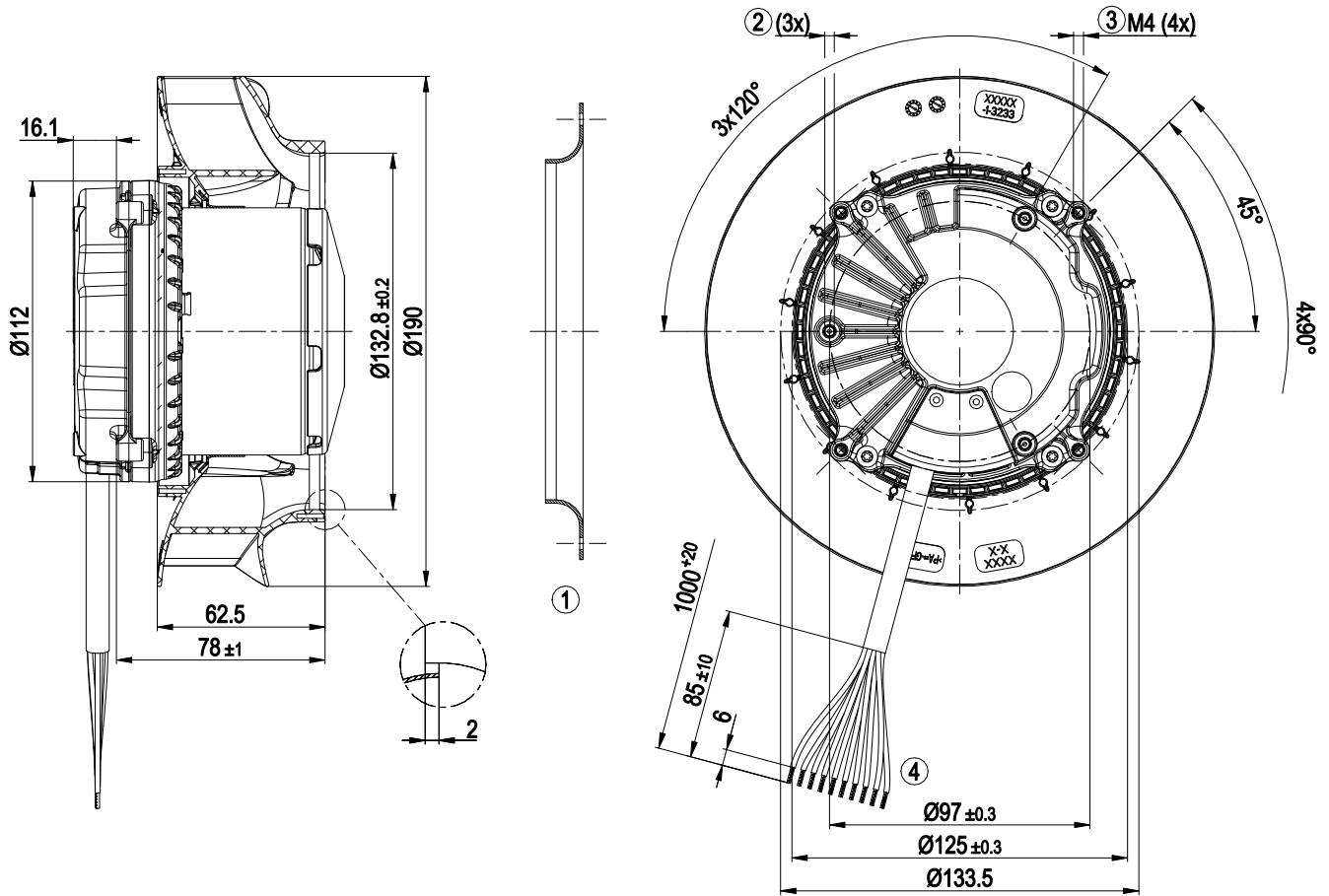

- | | |
|---|--|
| 1 | Accessory part: inlet ring 09576-2-4013 not included in scope of delivery |
| 2 | Tapping hole prepared for self-tapping M4 screw, max. screw-in depth 8 mm |
| 3 | Max. clearance for screw 10 mm |
| 4 | Cable, halogen-free, railway application EN 45545, 10G 1.0 mm ² |
| | 10x lead tip |



EC centrifugal fan - RadiCal

backward-curved, single-intake

for rail applications

Connection diagram

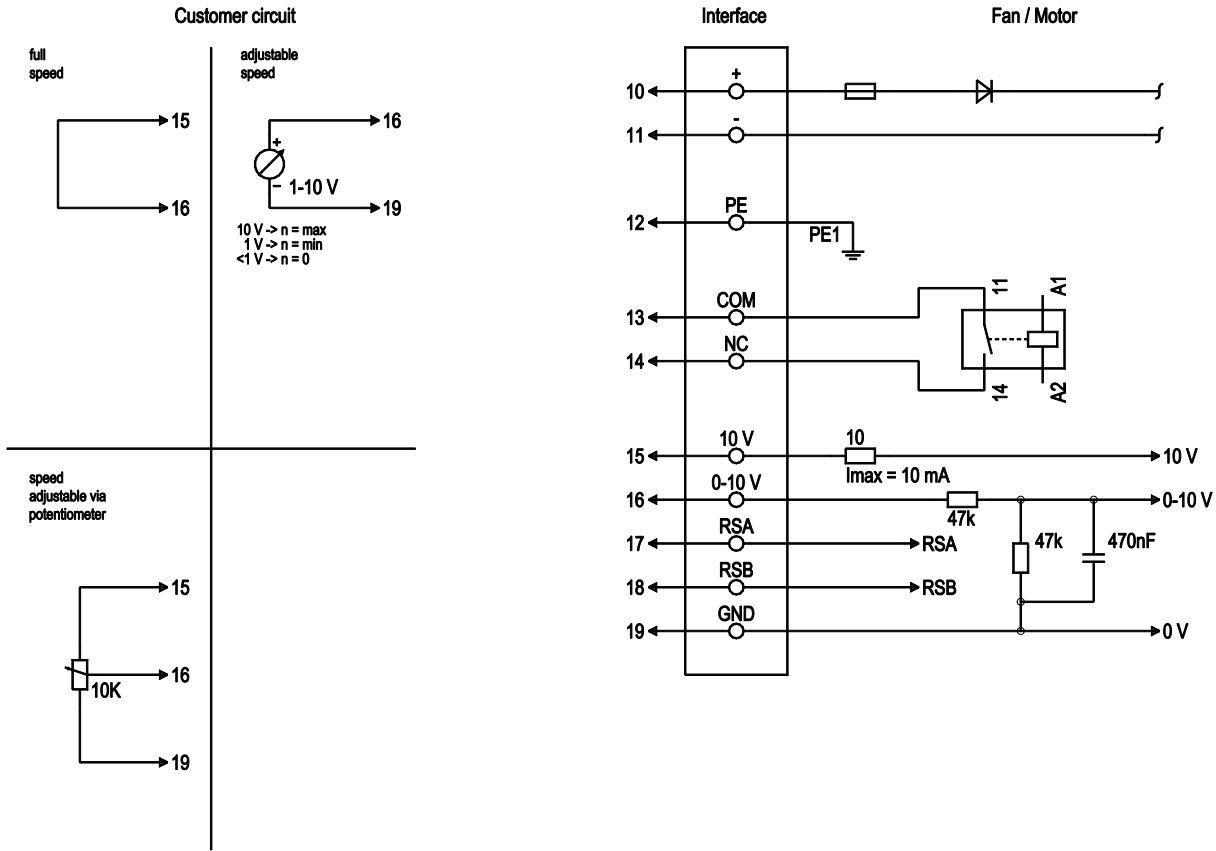

No.	Conn.	Designation	Color	Function/assignment
10	+		brown	Power supply, see nameplate for voltage range
11	-		black	Power supply, see nameplate for voltage range
12	PE		green/yellow	Protective earth
13	COM		gray	Status relay, floating status contact, common connection, contact rating 250 VAC/30 VDC max. 2 A (AC1), min. 1 mA/5 VDC, reinforced insulation on control interface side, basic insulation on supply side in accordance with EN 50124-1
14	NO		purple	Status relay, floating status contact, normally open contact, contact rating 250 VAC/30 VDC max. 2 A (AC1), min. 1 mA/5 VDC, reinforced insulation on control interface side, basic insulation on supply side in accordance with EN 50124-1
15	+10 V		red	Fixed voltage output 10 VDC, SELV, +10 V +/-3%, max. 10 mA, short-circuit-proof, power supply for external devices (e.g. potentiometers)
16	0-10 V		yellow	Analog input (set value) SELV, 0-10 V, R _i = 100 kΩ, adjustable curve
17	RSA		white	RS-485 interface for MODBUS, RSA; SELV, bus termination resistor provided by customer
18	RSB		orange	RS-485 interface for MODBUS, RSB; SELV, bus termination resistor provided by customer
19	GND		blue	Reference ground for control interface, SELV



Curves: Air performance

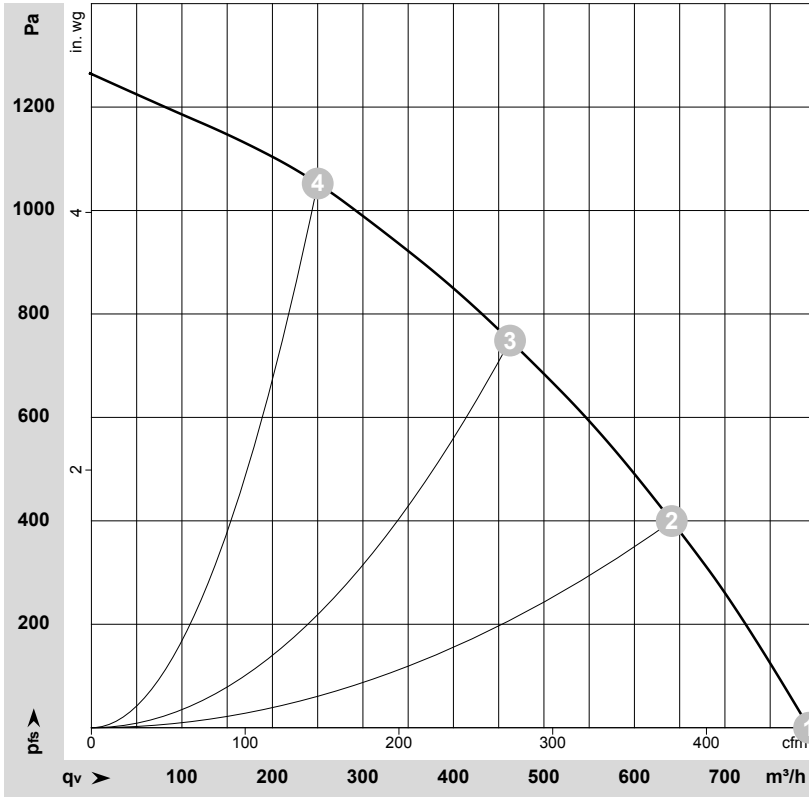

$\rho = 1.15 \text{ kg/m}^3 \pm 2 \%$

Measurement: LU-198884-1

Air performance measured according to ISO 5801 installation category A. For detailed information on the measurement setup, contact ebmpapst. Intake sound level: Sound power level according to ISO 13347 / sound pressure level measured at 1 m distance from fan axis. The values given are valid under the specified measuring conditions and may vary due to conditions of installation. For deviations from the standard configuration, the parameters have to be checked on the installed unit.

Measured values

	U	n	P _{ed}	I	LpA _{in}	LwA _{in}	q _v	p _{fs}	q _v	p _{fs}
	V	min ⁻¹	W	A	dB(A)	dB(A)	m ³ /h	Pa	cfm	in. wg
1	80	5060	240	3.00	77	85	795	0	465	0.00
2	80	4875	240	3.00	73	81	640	400	375	1.61
3	80	4800	240	3.00	70	79	465	750	275	3.01
4	80	5100	240	3.00	75	83	250	1050	145	4.22

U = Voltage · n = Speed (rpm) · P_{ed} = Power consumption · I = Current draw · LpA_{in} = Sound pressure level intake side · LwA_{in} = Sound power level intake side · q_v = Air flow
 p_{fs} = Pressure increase

