

R3G190-RV65-02

EC centrifugal fan - RadiCal

backward-curved, single-intake

for rail applications



R3G190-RV65-02 ebmpapst Datasheet FansCo

sales@fansco.com

www.fansco.com

Nominal data

Type	R3G190-RV65-02	
Motor	M3G074-BF	
Nominal voltage	VDC	110
Method of obtaining data		ml
Speed (rpm)	min ⁻¹	3950
Power consumption	W	155
Current draw	A	1.4
Min. ambient temperature	°C	-40
Max. ambient temperature	°C	60

ml = Max. load · me = Max. efficiency · fa = Free air · cs = Customer specification · ce = Customer equipment
Subject to change



Technical description

Weight	1.87 kg
Size	190 mm
Motor size	74
Rotor surface	Painted black
Electronics housing material	Die-cast aluminum
Impeller material	PA plastic UL94 V0
Number of blades	7
Direction of rotation	Clockwise, viewed toward rotor
Degree of protection	IP44; installation- and position-dependent
Insulation class	"B"
Moisture (F) / Environmental (H) protection class	H3
Max. permitted ambient temp. for motor (transport/storage)	+80 °C
Min. permitted ambient temp. for motor (transport/storage)	-40 °C
Installation position	Shaft horizontal or rotor on bottom; rotor on top on request
Condensation drainage holes	On rotor side
Mode	S1
Motor bearing	Ball bearing; (sealed)
Technical features	<ul style="list-style-type: none"> - Output 10 VDC, max. 10 mA - Alarm relay - Run monitoring - Power limiter - Motor current limitation - Soft start - Control input 0-10 VDC / PWM - Thermal overload protection for electronics/motor - Reverse polarity protection
Motor protection	Thermal overload protector (TOP) internally connected
With cable	Variable
Protection class	I (with customer connection of protective earth)
Conformity with standards	EN 15085-1, CPC3: 2007; EN 45545-2, HL3: 2013; EN 50155: 2008; EN 61373, Cat. 1B: 2010; CE
Approval	EAC
Comment	Only suitable for indoor use

EC centrifugal fan - RadiCal

backward-curved, single-intake
for rail applications

Product drawing

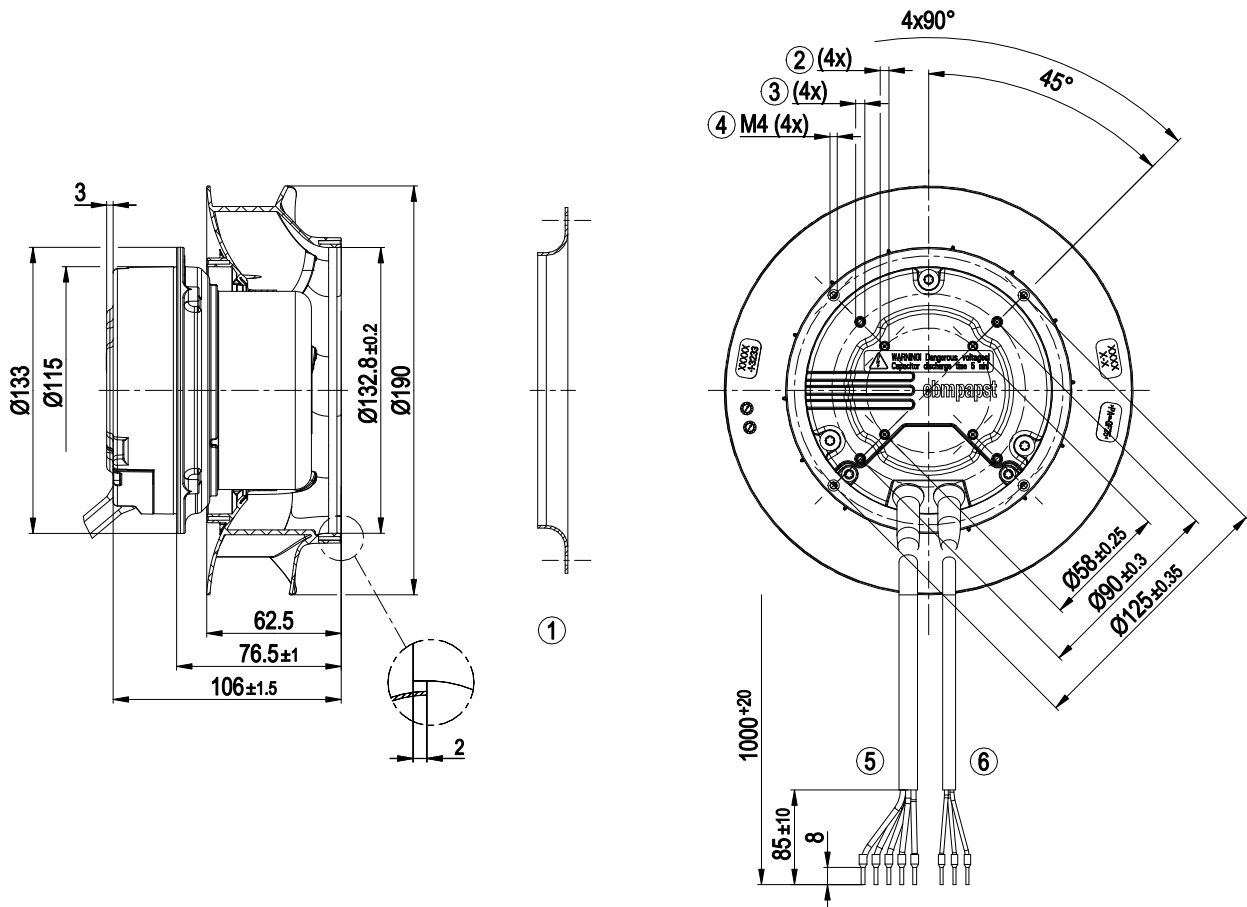

1	Accessory part: inlet ring 09576-2-4013 not included in scope of delivery
2	Tapping hole prepared for self-tapping M4 screw, max. screw-in depth 8 mm
3	Tapping hole prepared for self-tapping M4 screw, max. screw-in depth 6 mm
4	Max. clearance for screw 10 mm
5	Cable, halogen-free, railway application EN 45545, 5G 1.0 mm ² 5x wire-end ferrule
6	Cable, halogen-free, railway application EN 45545, 3x 0.33 mm ² 3x wire-end ferrule



EC centrifugal fan - RadiCal

backward-curved, single-intake

for rail applications

Accessory part

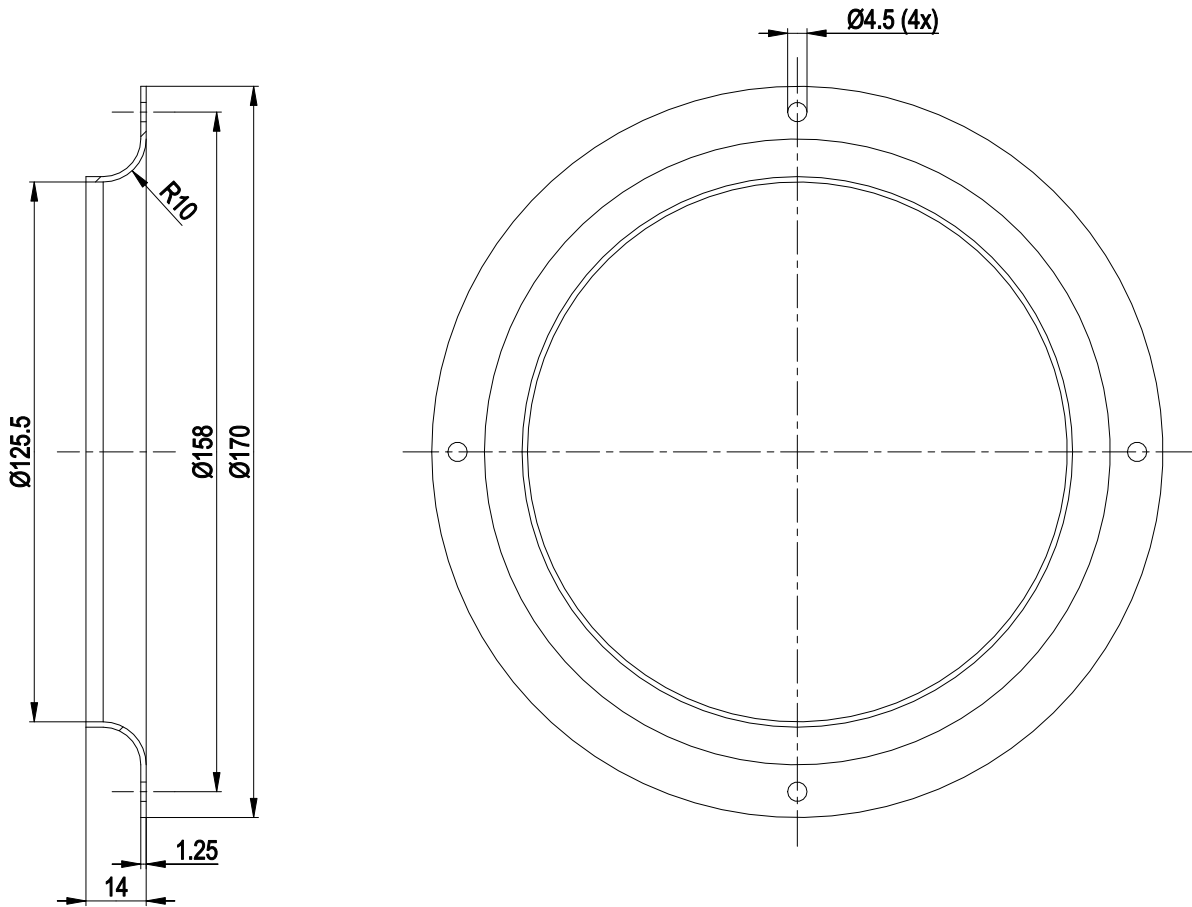

1 Accessory part: inlet ring 09576-2-4013 not included in scope of delivery



Connection diagram

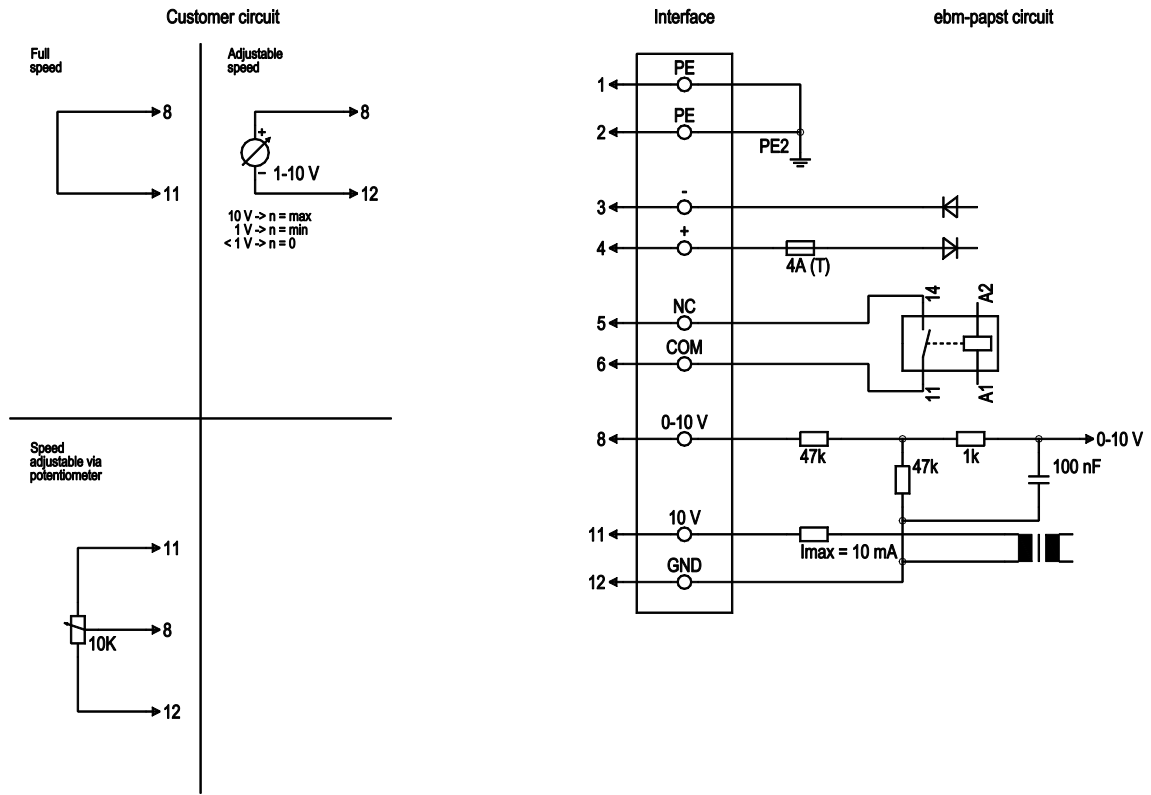

No.	Conn.	Designation	Function/assignment
1	1, 2	PE	Protective earth
1	3	-	Power supply, GND (110 VDC)
1	4	+	Power supply, 110 VDC
1	5	NC	Floating status contact (0.3 A - 110 VDC, 1 A - 60 VDC, 3 A - 30 VDC), closed at $n \geq 100$ rpm, break for failure
1	6	COM	Floating status contact, closed at $n \geq 100$ rpm, break for failure
2	8	0-10 V	Control input, set value 0-10 VDC, impedance 100 k Ω ; SELV
2	11	10 VDC	Voltage output 10 VDC ($\pm 3\%$), max. 10 mA, power supply for external devices (e.g. potentiometer); SELV
2	12	GND	Reference ground for control interface, SELV



Curves: Air performance

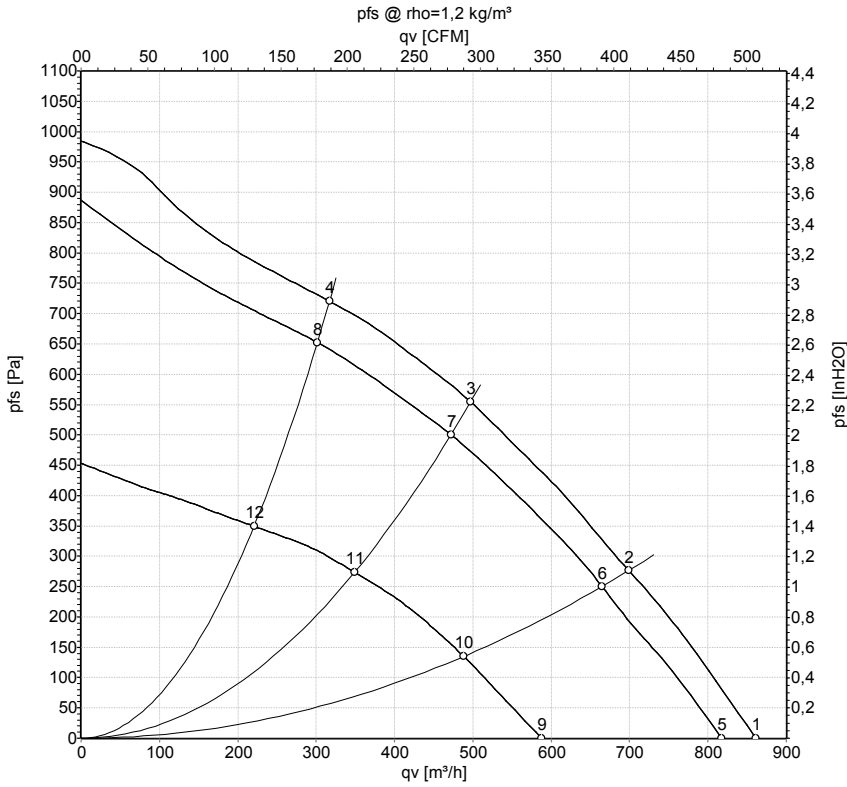

Measurement: LU-159693-1
 Measurement: LU-159560-1
 Measurement: LU-159692-1

Air performance measured according to ISO 5801 installation category A. For detailed information on the measurement setup, contact ebmpapst. Intake sound level: Sound power level according to ISO 13347 / sound pressure level measured at 1 m distance from fan axis. The values given are valid under the specified measuring conditions and may vary due to conditions of installation. For deviations from the standard configuration, the parameters have to be checked on the installed unit.

Measured values

	U	n	P _{ed}	I	LpA _{in}	LwA _{in}	q _v	P _{fs}	q _v	P _{fs}
	V	min ⁻¹	W	A	dB(A)	dB(A)	m ³ /h	Pa	cfm	in. wg
1	138	4330	151	1.10			860	0	505	0.00
2	138	4220	165	1.20			700	276	410	1.11
3	138	4150	173	1.26			495	557	295	2.24
4	138	4250	164	1.19			315	721	185	2.89
5	110	4130	131	1.19	69	77	815	0	480	0.00
6	110	4015	146	1.33	67	74	665	250	390	1.00
7	110	3950	155	1.40	66	73	470	500	280	2.01
8	110	4025	144	1.32	68	75	300	650	180	2.61
9	77	3010	55	0.71			590	0	345	0.00
10	77	2970	61	0.79			490	135	285	0.54
11	77	2935	68	0.88			350	274	205	1.10
12	77	2965	61	0.79			220	349	130	1.40

U = Voltage · n = Speed (rpm) · P_{ed} = Power consumption · I = Current draw · LpA_{in} = Sound pressure level intake side · LwA_{in} = Sound power level intake side · q_v = Air flow
 p_{fs} = Pressure increase

