

R3G190-RH54-12 ebmpapst Datasheet
 sales@fansco.com
 www.fansco.com

Limited partnership · Headquarters Muldingen
 Amtsgericht (court of registration) Stuttgart · HRA 590344

General partner Elektrobau Muldingen GmbH · Headquarters Muldingen
 Amtsgericht (court of registration) Stuttgart · HRB 590142



Nominal data

Type	R3G190-RH54-12	
Motor	M3G074-BF	
Phase		1~
Nominal voltage	VAC	230
Frequency	Hz	50/60
Method of obtaining data		ml
Speed (rpm)	min ⁻¹	4180
Power consumption	W	170
Current draw	A	1.3
Min. ambient temperature	°C	-25
Max. ambient temperature	°C	60

ml = Max. load · me = Max. efficiency · fa = Free air · cs = Customer specification · ce = Customer equipment
 Subject to change

Data according to ErP Directive

		Actual	Req. 2015			
01 Overall efficiency η_{es}	%	55.1	43.1	09 Power consumption P_{ed}	kW	0.16
02 Measurement category		A		09 Air flow q_v	m ³ /h	565
03 Efficiency category		Static		09 Pressure increase p_{fs}	Pa	523
04 Efficiency grade N		74	62	10 Speed (rpm) n	min ⁻¹	4120
05 Variable speed drive		Yes		11 Specific ratio*		1.01

Data obtained at optimum efficiency level.

The ErP data is determined using a motor-impeller combination in a standardized measurement setup.

* Specific ratio = $1 + p_s / 100\,000\text{ Pa}$

LU-128667



Technical description

Weight	1.9 kg
Fan size	190 mm
Rotor surface	Thick-film passivated
Electronics housing material	Die-cast aluminum
Impeller material	PA plastic
Number of blades	7
Direction of rotation	Clockwise, viewed toward rotor
Degree of protection	IP44
Insulation class	"B"
Moisture (F) / Environmental (H) protection class	F3-1
Max. permitted ambient temp. for motor (transport/storage)	+ 80 °C
Min. permitted ambient temp. for motor (transport/storage)	- 40 °C
Installation position	Any
Condensation drainage holes	None
Mode	S1
Motor bearing	Ball bearing
Technical features	<ul style="list-style-type: none"> - Output 10 VDC, max. 1.1 mA - Tach output - Power limiter - Motor current limitation - Soft start - Control input 0-10 VDC / PWM - Control interface with SELV potential safely disconnected from the mains - Thermal overload protection for motor
Touch current according to IEC 60990 (measuring circuit Fig. 4, TN system)	<= 3.5 mA
Motor protection	Thermal overload protector (TOP) internally connected
With cable	Variable
Protection class	I (with customer connection of protective earth)
Conformity with standards	EN 60335-1

Product drawing

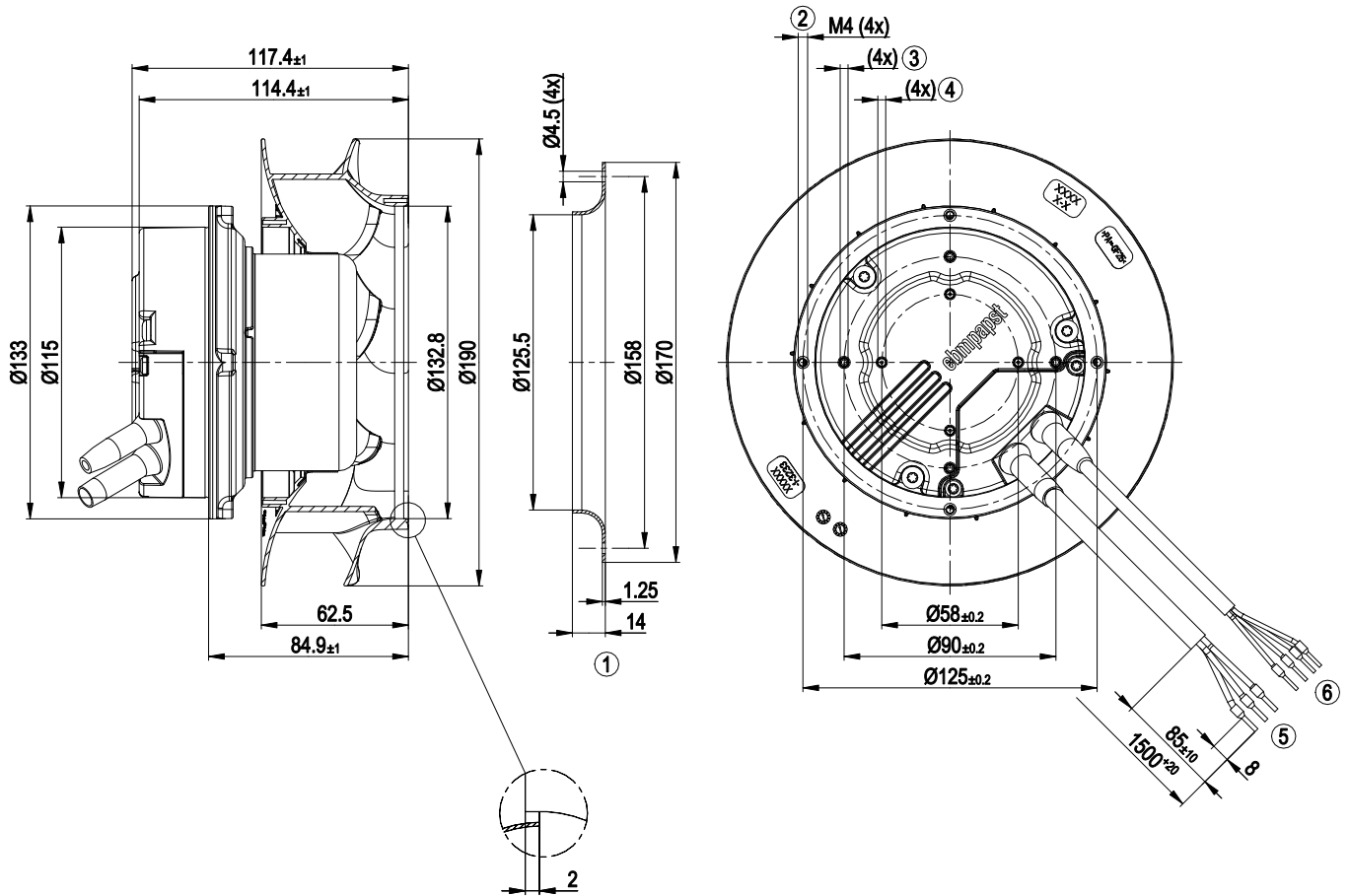

1	Accessory part: inlet ring 09576-2-4013 not included in scope of delivery
2	Clearance for screw 8 - 10 mm
3	Tapping hole ready for self-tapping M4 screw, max. clearance for screw 6 mm
4	Tapping hole ready for self-tapping M4 screw, max. clearance for screw 8 mm
5	Cable PVC AWG22, 4x crimped ferrules
6	Cable PVC AWG18, 3x crimped ferrules



Connection diagram

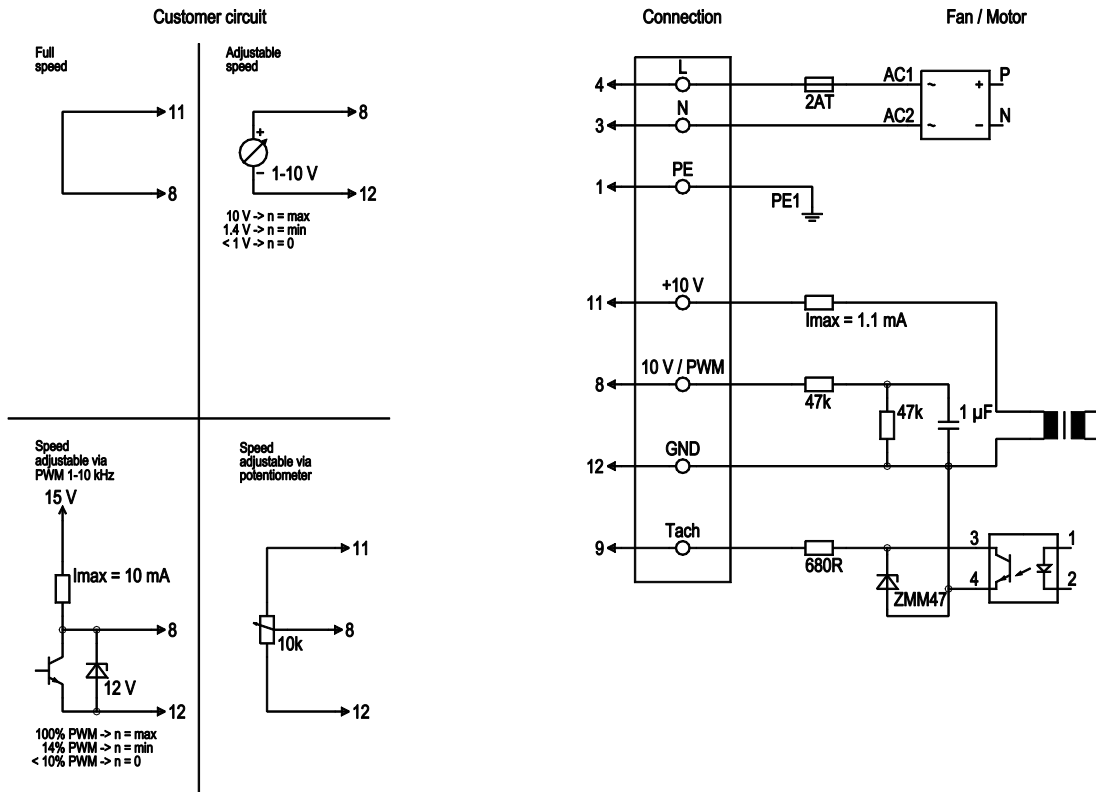

No.	Conn.	Designation	Color	Function/assignment
	4	L	black	Power supply 230 VAC, 50-60 Hz, see nameplate for voltage range
	3	N	blue	Neutral conductor
	1	PE	green/yellow	Protective earth
	8	0-10 V PWM	yellow	Control input 0-10 V or PWM, electrically isolated
	9	Tach	white	Tach output: open collector, 1 pulse per revolution, electrically isolated
	11	10V / max 1.1 mA	red	Voltage output 10 V/max. 1.1 mA, electrically isolated
	12	GND	blue	GND connection for control interface

Curves: Air performance 50 Hz

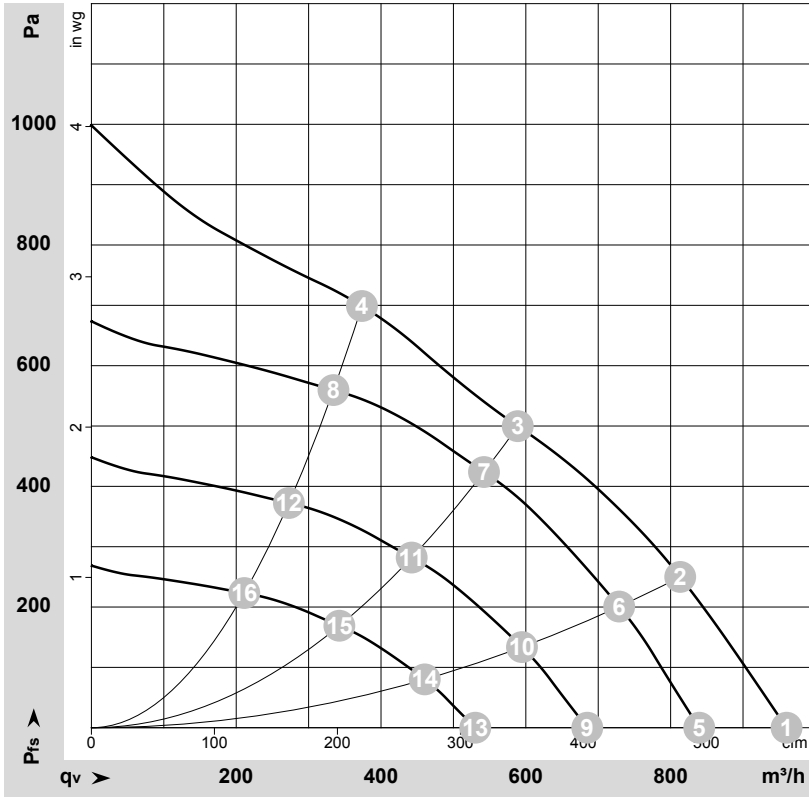

$\rho = 1.15 \text{ kg/m}^3 \pm 2 \%$

Measurement: LU-128667-1

Air performance measured according to ISO 5801 installation category A. For detailed information on the measurement setup, contact ebmpapst. Intake sound level: Sound power level according to ISO 13347 / sound pressure level measured at 1 m distance from fan axis. The values given are valid under the specified measuring conditions and may vary due to conditions of installation. For deviations from the standard configuration, the parameters have to be checked on the installed unit.

Measured values

	U	f	n	P _{ed}	I	qv	p _{fs}	qv	p _{fs}
	V	Hz	min ⁻¹	W	A	m ³ /h	Pa	CFM	inH2O
1	230	50	4345	154	1.24	960	0	565	0.00
2	230	50	4240	165	1.30	815	250	480	1.00
3	230	50	4180	170	1.30	590	500	345	2.01
4	230	50	4245	167	1.30	375	700	220	2.81
5	230	50	3800	103	0.83	840	0	495	0.00
6	230	50	3800	119	0.94	730	201	430	0.81
7	230	50	3800	132	1.05	540	424	320	1.70
8	230	50	3800	119	0.94	335	560	195	2.25
9	230	50	3100	56	0.45	685	0	405	0.00
10	230	50	3100	65	0.51	595	134	350	0.54
11	230	50	3100	72	0.57	440	282	260	1.13
12	230	50	3100	65	0.51	275	372	160	1.49
13	230	50	2400	26	0.21	530	0	310	0.00
14	230	50	2400	30	0.24	460	80	270	0.32
15	230	50	2400	33	0.27	340	169	200	0.68
16	230	50	2400	30	0.24	210	223	125	0.90

U = Power supply · f = Frequency · n = Speed (rpm) · P_{ed} = Power consumption · I = Current draw · qv = Air flow · p_{fs} = Pressure increase

