

R3G180-AI17-09 ebmpapst Datasheet

sales@fansco.com

www.fansco.com

Limited partnership · Headquarters Mulfingen

Amtsgericht (court of registration) Stuttgart · HRA 590344

General partner Elektrobau Mulfingen GmbH · Headquarters Mulfingen

Amtsgericht (court of registration) Stuttgart · HRB 590142

Nominal data

Type	R3G180-AI17-09	
Motor	M3G055-CF	
Phase		1~
Nominal voltage	VAC	230
Nominal voltage range	VAC	200 .. 240
Frequency	Hz	50/60
Method of obtaining data		ml
Speed (rpm)	min ⁻¹	3000
Power consumption	W	77
Current draw	A	0.73
Min. ambient temperature	°C	-25
Max. ambient temperature	°C	50

ml = Max. load · me = Max. efficiency · fa = Free air · cs = Customer specification · ce = Customer equipment
Subject to change



Technical description

Weight	3 kg
Fan size	180 mm
Rotor surface	Unpainted
Terminal box material	PA plastic
Impeller material	Sheet steel, rust-resistant
Direction of rotation	Clockwise, viewed toward rotor
Degree of protection	IP54
Insulation class	"B"
Moisture (F) / Environmental (H) protection class	H0 - dry environment
Max. permitted ambient temp. for motor (transport/storage)	+ 80 °C
Min. permitted ambient temp. for motor (transport/storage)	- 40 °C
Installation position	Any
Condensation drainage holes	None
Mode	S1
Motor bearing	Ball bearing
Technical features	<ul style="list-style-type: none"> - Output 10 VDC, max. 1.1 mA - Tach output - Motor current limitation - Soft start - Control input 0-10 VDC / PWM - Control interface with SELV potential safely disconnected from supply - Thermal overload protection for electronics/motor
EMC immunity to interference	According to EN 61000-6-2 (industrial environment)
EMC circuit feedback	According to EN 61000-3-2/3
EMC interference emission	According to EN 61000-6-3 (household environment), on account of the installation conditions, ferritic damping in the cable may be required for the application.
Touch current according to IEC 60990 (measuring circuit Fig. 4, TN system)	<= 3.5 mA
Electrical hookup	With plug
Motor protection	Locked-rotor protection
Protection class	I (with customer connection of protective earth)
Conformity with standards	CE

Product drawing

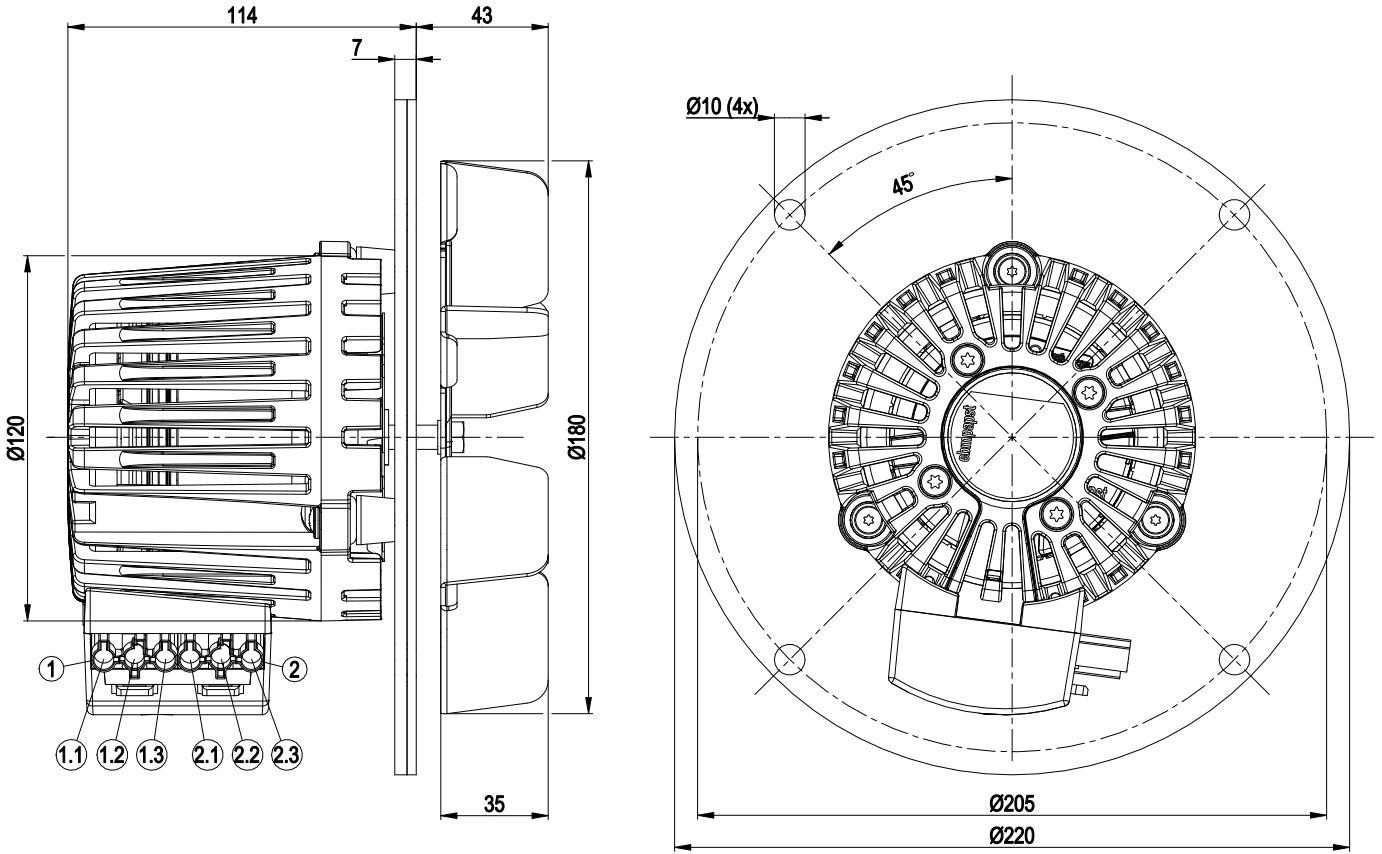

1	3-pole connector housing Wieland 93.031.3257.0
1.1	PWM / 0-10 V
1.2	GND
1.3	Tach
2	3-pole connector housing Wieland 93.031.3757.0
2.1	N
2.2	PE
2.3	L



Connection diagram

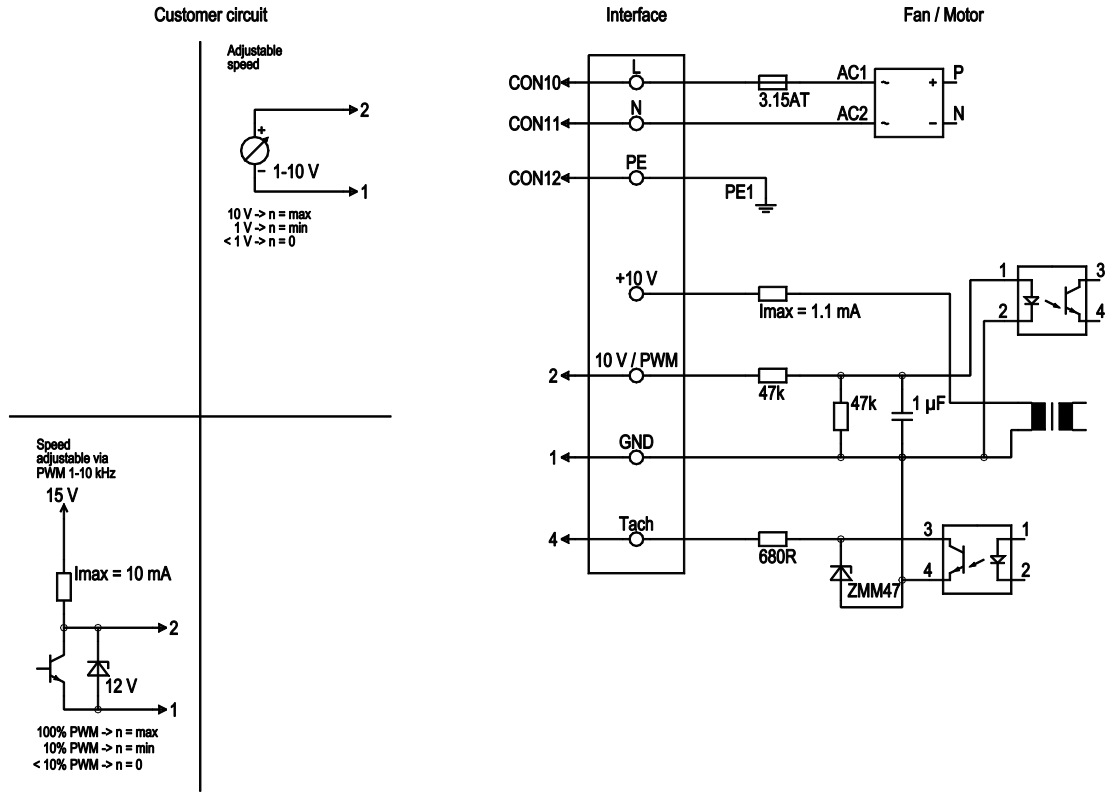

No.	Conn.	Designation	Color	Function/assignment
	CON10	L	black	Power supply 230 VAC, 50-60 Hz, see nameplate for voltage range
	CON11	N	blue	Neutral conductor
	CON12	PE	green/yellow	Protective earth
	1	GND	blue	GND connection for control interface
	2	0- 10V PWM	yellow	Control input 0-10 V or PWM, electrically isolated
	4	Tach	white	Tach output: open collector, 1 pulse per revolution, electrically isolated

Curves: Air performance 50 Hz

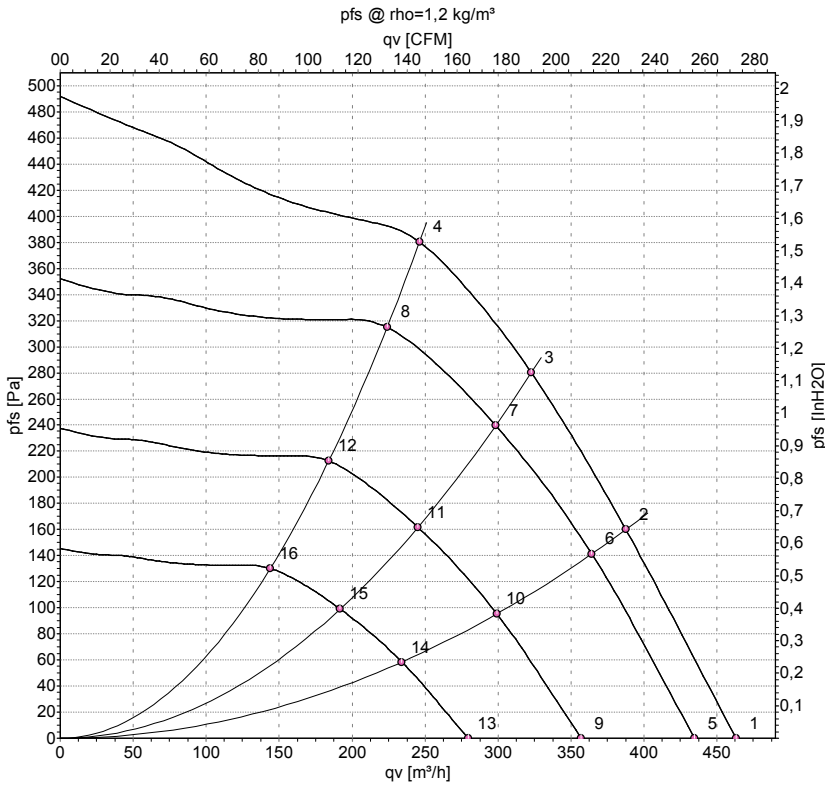

Measurement: LU-156445-1

Air performance measured according to ISO 5801 installation category A. For detailed information on the measurement setup, contact ebm-papst. Intake sound level: Sound power level according to ISO 13347 / sound pressure level measured at 1 m distance from fan axis. The values given are valid under the specified measuring conditions and may vary due to conditions of installation. For deviations from the standard configuration, the parameters have to be checked on the installed unit.

Measured values

	U	f	n	P _{ed}	I	q _v	p _{fs}	q _v	p _{fs}
	V	Hz	min ⁻¹	W	A	m ³ /h	Pa	cfm	inH2O
1	230	50	3000	77	0.73	465	0	275	0.00
2	230	50	2980	77	0.73	390	160	230	0.64
3	230	50	3030	75	0.71	325	280	190	1.12
4	230	50	3075	70	0.67	245	380	145	1.53
5	230	50	2800	64	0.60	435	0	255	0.00
6	230	50	2800	64	0.60	365	141	215	0.57
7	230	50	2800	59	0.56	300	240	175	0.96
8	230	50	2800	53	0.51	225	317	130	1.27
9	230	50	2300	36	0.33	355	0	210	0.00
10	230	50	2300	35	0.33	300	95	175	0.38
11	230	50	2300	33	0.31	245	162	145	0.65
12	230	50	2300	29	0.28	185	214	110	0.86
13	230	50	1800	17	0.16	280	0	165	0.00
14	230	50	1800	17	0.16	235	58	140	0.23
15	230	50	1800	16	0.15	190	99	115	0.40
16	230	50	1800	14	0.13	145	131	85	0.53

U = Power supply · f = Frequency · n = Speed (rpm) · P_{ed} = Power consumption · I = Current draw · q_v = Air flow · p_{fs} = Pressure increase

