

R3G160-RB31-10 ebmpapst Datasheet

sales@fansco.com

www.fansco.com

Limited partnership · Headquarters Muldingen

Amtsgericht (court of registration) Stuttgart · HRA 590344

General partner Elektrobau Muldingen GmbH · Headquarters Muldingen

Amtsgericht (court of registration) Stuttgart · HRB 590142

Nominal data

Type	R3G160-RB31-10	
Motor	M3G055-BD	
Phase		1~
Nominal voltage	VAC	230
Nominal voltage range	VAC	200 .. 240
Frequency	Hz	50/60
Method of obtaining data		ml
Speed (rpm)	min ⁻¹	4300
Power consumption	W	85
Current draw	A	0.75
Min. ambient temperature	°C	-25
Max. ambient temperature	°C	60

ml = Max. load · me = Max. efficiency · fa = Free air · cs = Customer specification · ce = Customer equipment
Subject to change



Technical description

Weight	0.88 kg
Size	160 mm
Motor size	55
Rotor surface	Thick-film passivated
Impeller material	PP plastic
Direction of rotation	Clockwise, viewed toward rotor
Degree of protection	IP54
Insulation class	"B"
Moisture (F) / Environmental (H) protection class	H1
Max. permitted ambient temp. for motor (transport/storage)	+ 80 °C
Min. permitted ambient temp. for motor (transport/storage)	- 40 °C
Installation position	Any
Condensation drainage holes	None, open rotor
Mode	S1
Motor bearing	Ball bearing
Technical features	<ul style="list-style-type: none"> - Output 10 VDC, max. 1.1 mA - Tach output - Power limiter - Motor current limitation - Soft start - Control input 0-10 VDC / PWM - Control interface with SELV potential safely disconnected from the mains - Overvoltage detection - Thermal overload protection for electronics/motor - Line undervoltage detection
EMC immunity to interference	According to EN 61000-6-2 (industrial environment)
EMC circuit feedback	According to EN 61000-3-2/3
EMC interference emission	According to EN 61000-6-3 (household environment)
Touch current according to IEC 60990 (measuring circuit Fig. 4, TN system)	<= 3.5 mA
Motor protection	Electronic motor protection
With cable	Variable
Protection class	I (with customer connection of protective earth)
Conformity with standards	EN 60335-1; CE

Product drawing

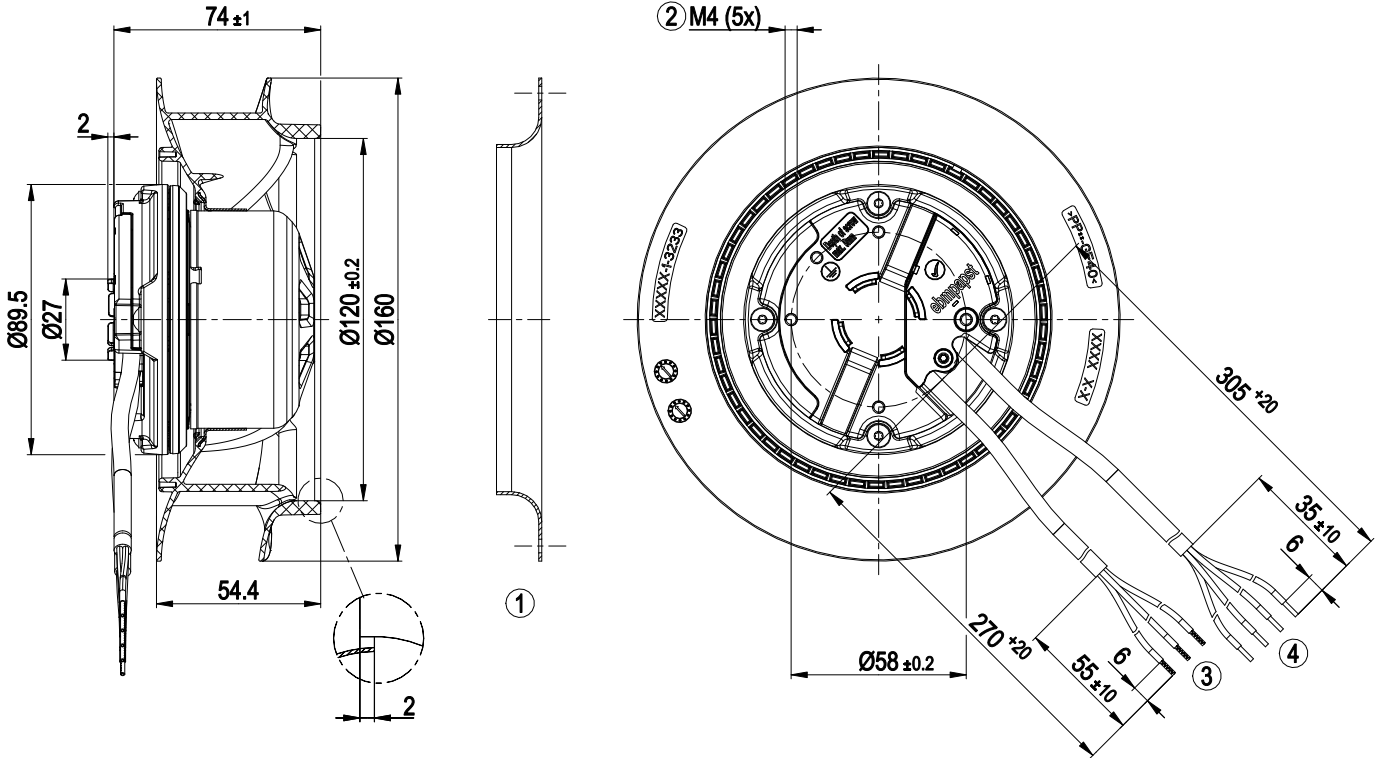

1	Accessory part: Inlet ring 09567-2-4013 not included in scope of delivery
2	Max. clearance for screw 5 mm
3	Cable AWG20 3x splice
4	Cable PVC AWG22 4x splice



Accessory part

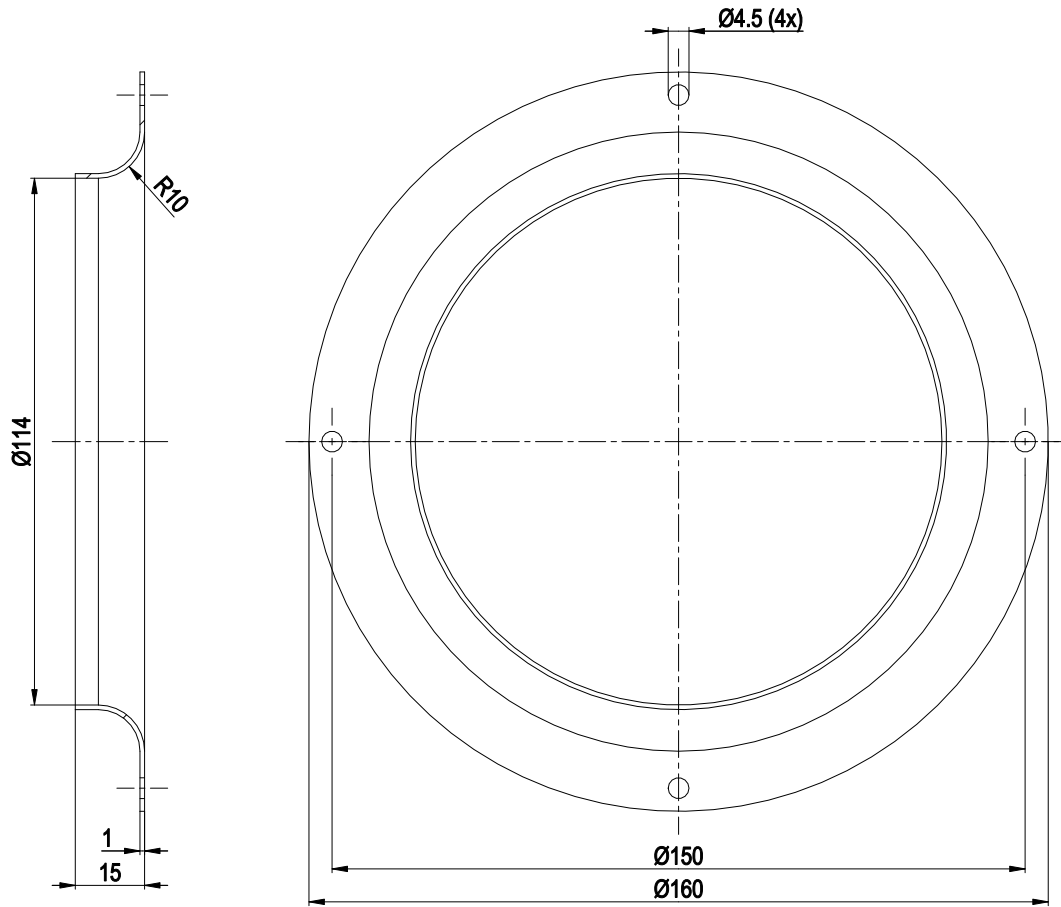

Inlet ring 09567-2-4013



Connection diagram

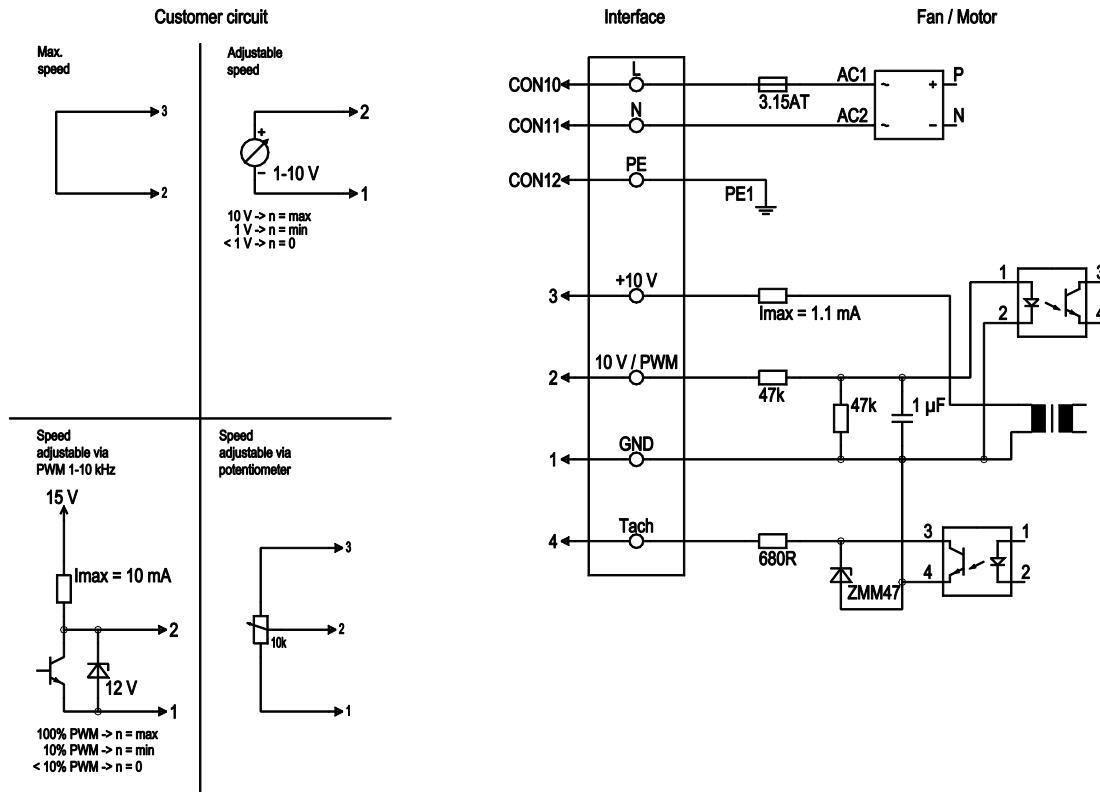

No.	Conn.	Designation	Color	Function/assignment
	CON10	L	black	Power supply 230 VAC, 50-60 Hz, see nameplate for voltage range
	CON11	N	blue	Neutral conductor
	CON12	PE	green/yellow	Protective earth
	1	GND	blue	GND connection for control interface
	2	0-10V PWM	yellow	Control input 0-10 V or PWM, electrically isolated
	3	10 V / max. 1,1 mA	red	Voltage output 10 VDC 1.1 mA, electrically isolated, short-circuit-proof
	4	Tacho	white	Tach output: open collector, 1 pulse per revolution, electrically isolated



Curves: Air performance 50 Hz

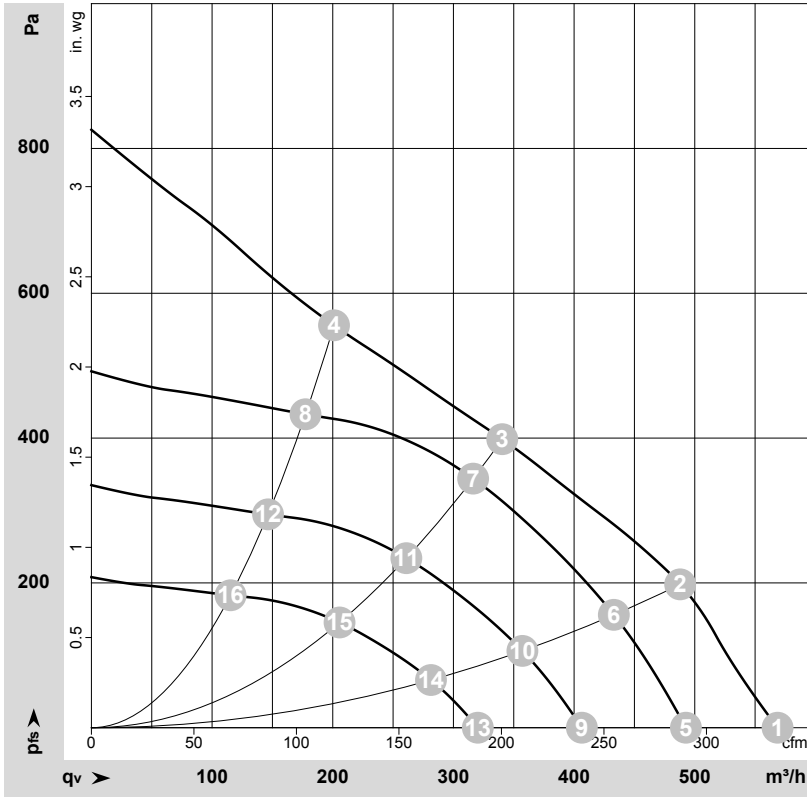

$\rho = 1.15 \text{ kg/m}^3 \pm 2 \%$

Measurement: LU-193699-1

Air performance measured according to ISO 5801 installation category A. For detailed information on the measurement setup, contact ebmpapst. Intake sound level: Sound power level according to ISO 13347 / sound pressure level measured at 1 m distance from fan axis. The values given are valid under the specified measuring conditions and may vary due to conditions of installation. For deviations from the standard configuration, the parameters have to be checked on the installed unit.

Measured values

	Wired	U	f	n	P _{ed}	I	LpA _{in}	LwA _{in}	q _v	P _{fs}	q _v	P _{fs}
		V	Hz	min ⁻¹	W	A	dB(A)	dB(A)	m ³ /h	Pa	cfm	in. wg
1	1~	230	50	4615	85	0.75	68	76	570	0	335	0.00
2	1~	230	50	4510	85	0.75	65	74	490	200	285	0.80
3	1~	230	50	4300	85	0.75	60	68	340	400	200	1.61
4	1~	230	50	4530	85	0.75	65	74	200	550	120	2.21
5	1~	230	50	4000	55	0.48	65	73	495	0	290	0.00
6	1~	230	50	4000	59	0.51	63	71	435	157	255	0.63
7	1~	230	50	4000	67	0.59	58	66	315	345	185	1.39
8	1~	230	50	4000	59	0.51	62	71	175	433	105	1.74
9	1~	230	50	3300	31	0.27	60	68	405	0	240	0.00
10	1~	230	50	3300	33	0.29	58	66	355	107	210	0.43
11	1~	230	50	3300	38	0.33	53	61	260	235	155	0.94
12	1~	230	50	3300	33	0.29	57	66	145	294	85	1.18
13	1~	230	50	2600	15	0.13	54	62	320	0	190	0.00
14	1~	230	50	2600	16	0.14	52	60	280	66	165	0.26
15	1~	230	50	2600	18	0.16	47	55	205	146	120	0.59
16	1~	230	50	2600	16	0.14	51	60	115	183	70	0.73

Wired = Wiring · U = Voltage · f = Frequency · n = Speed (rpm) · P_{ed} = Power consumption · I = Current draw · LpA_{in} = Sound pressure level intake side · LwA_{in} = Sound power level intake side
 q_v = Air flow · P_{fs} = Pressure increase

