

R3G160-BA13-11 ebmpapst Datasheet  
 sales@fansco.com  
 www.fansco.com

Limited partnership · Headquarters Mulfingen  
 Amtsgericht (court of registration) Stuttgart · HRA 590344

General partner Elektrobau Mulfingen GmbH · Headquarters Mulfingen  
 Amtsgericht (court of registration) Stuttgart · HRB 590142

## Nominal data

<b>Type</b>	<b>R3G160-BA13-11</b>	
<b>Motor</b>	<b>M3G055-DF</b>	
Phase		1~
Nominal voltage	VAC	230
Nominal voltage range	VAC	200 .. 240
Frequency	Hz	50/60
Method of obtaining data		ml
Speed (rpm)	min <sup>-1</sup>	1840
Power consumption	W	115
Current draw	A	1
Min. ambient temperature	°C	-25
Max. ambient temperature	°C	60

ml = Max. load · me = Max. efficiency · fa = Free air · cs = Customer specification · ce = Customer equipment  
 Subject to change



### Technical description

<b>Weight</b>	1.6 kg
<b>Fan size</b>	160 mm
<b>Rotor surface</b>	Thick-film passivated
<b>Impeller material</b>	Sheet steel, galvanized
<b>Direction of rotation</b>	Clockwise, viewed toward rotor
<b>Degree of protection</b>	IP54
<b>Insulation class</b>	"B"
<b>Moisture (F) / Environmental (H) protection class</b>	H1
<b>Max. permitted ambient temp. for motor (transport/storage)</b>	+ 80 °C
<b>Min. permitted ambient temp. for motor (transport/storage)</b>	- 40 °C
<b>Installation position</b>	Any
<b>Condensation drainage holes</b>	None, open rotor
<b>Mode</b>	S1
<b>Motor bearing</b>	Ball bearing
<b>Technical features</b>	<ul style="list-style-type: none"> <li>- Output 10 VDC, max. 10 mA</li> <li>- Tach output</li> <li>- Power limiter</li> <li>- Motor current limitation</li> <li>- Soft start</li> <li>- Control input 0-10 VDC / PWM</li> <li>- Control interface with SELV potential safely disconnected from the mains</li> <li>- Overvoltage detection</li> <li>- Thermal overload protection for electronics/motor</li> <li>- Line undervoltage detection</li> </ul>
<b>EMC immunity to interference</b>	According to EN 61000-6-2 (industrial environment)
<b>EMC circuit feedback</b>	According to EN 61000-3-2/3
<b>EMC interference emission</b>	According to EN 61000-6-3 (household environment)
<b>Touch current according to IEC 60990 (measuring circuit Fig. 4, TN system)</b>	<= 3.5 mA
<b>Motor protection</b>	Electronic motor protection
<b>With cable</b>	Variable
<b>Protection class</b>	I (with customer connection of protective earth)
<b>Conformity with standards</b>	EN 60335-1; EN 60335-2-31; CE



Product drawing

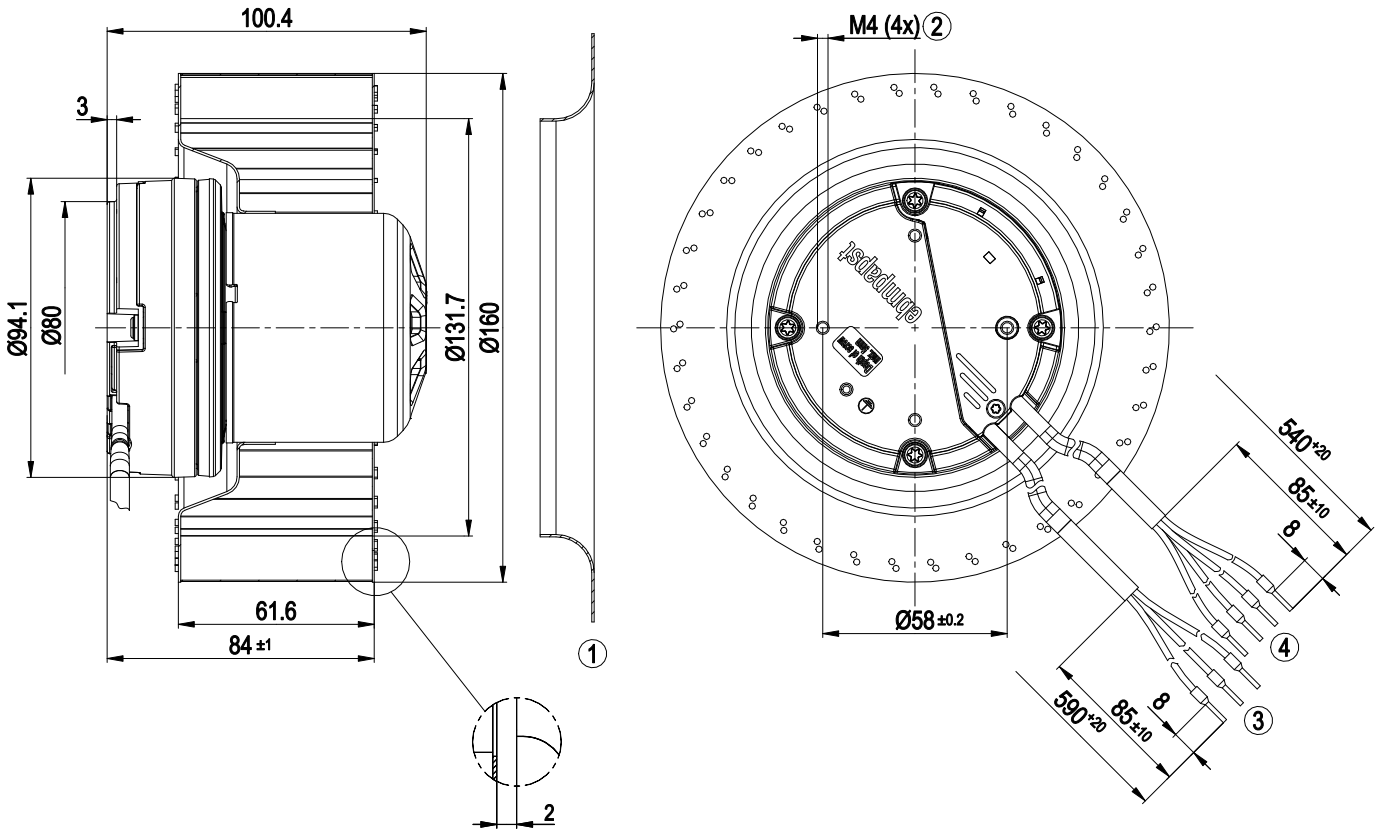

1	Accessory part: inlet ring 09588-2-4013 not included in scope of delivery
2	Max. clearance for screw 5 mm
3	Cable PVC 3G 0.5 mm <sup>2</sup> , 3x crimped ferrules
4	Cable PVC 4x 0.25 mm <sup>2</sup> , 4x crimped ferrules



Accessory part

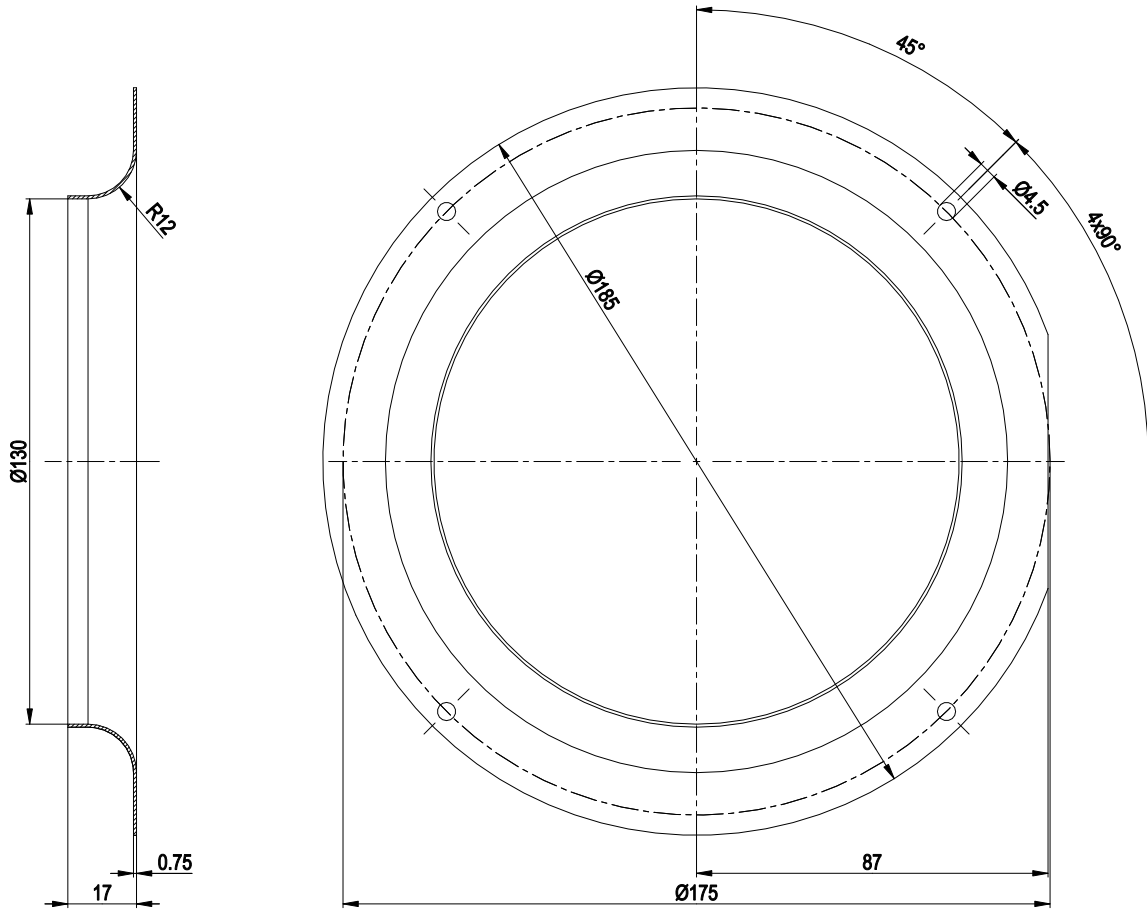

Accessory part: inlet ring 09588-2-4013 not included in scope of delivery



## Connection diagram

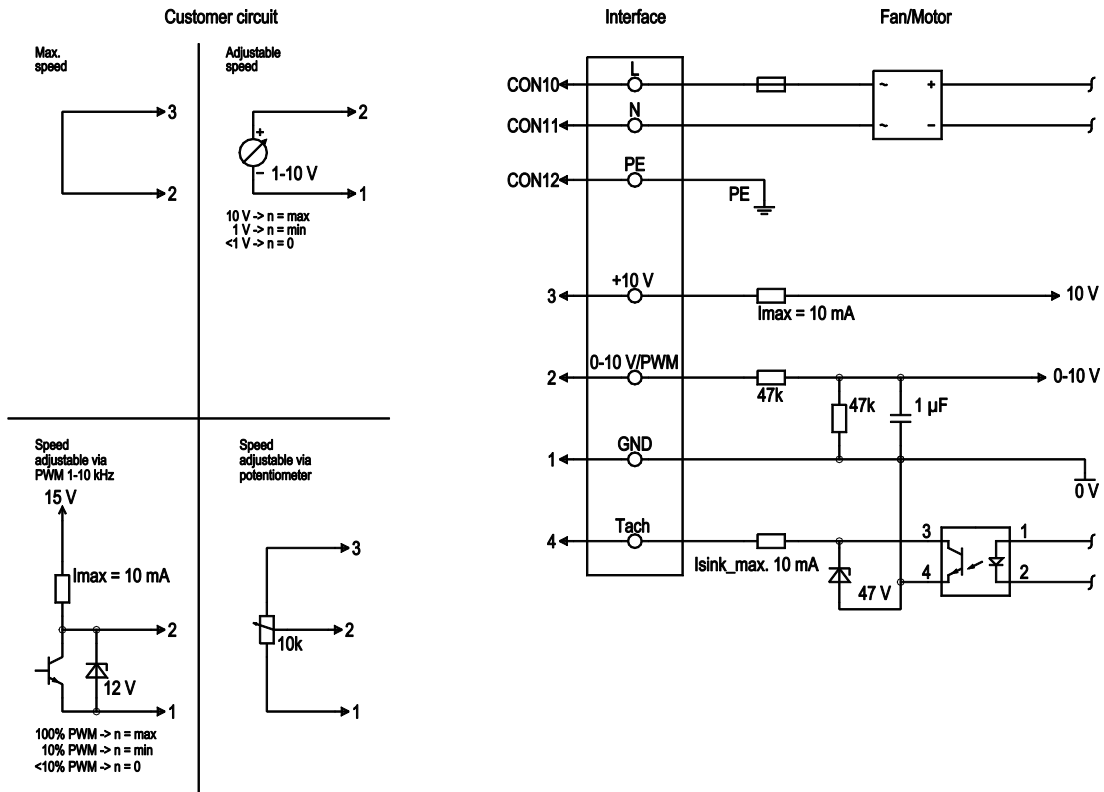

No.	Conn.	Designation	Color	Function/assignment
	CON10	L	brown	Supply connection, power supply, phase, see nameplate for voltage range
	CON11	N	blue	Supply connection, power supply, neutral conductor, see nameplate for voltage range
	CON12	PE	green/yellow	Ground connection
	2	0- 10V PWM	yellow	0-10 V / PWM control input, R <sub>i</sub> =100 kΩ, SELV
	4	Tach	white	Tach output, open collector, 1 pulse per revolution, I <sub>sink max</sub> = 10 mA, SELV
	3	+10 V	red	Fixed voltage output 10 VDC +/-3 %, I <sub>max</sub> . 10 mA, short-circuit-proof, power supply for ext. devices (e.g. pot), SELV
	1	GND	blue	Reference ground for control interface, SELV



## Curves: Air performance 50 Hz

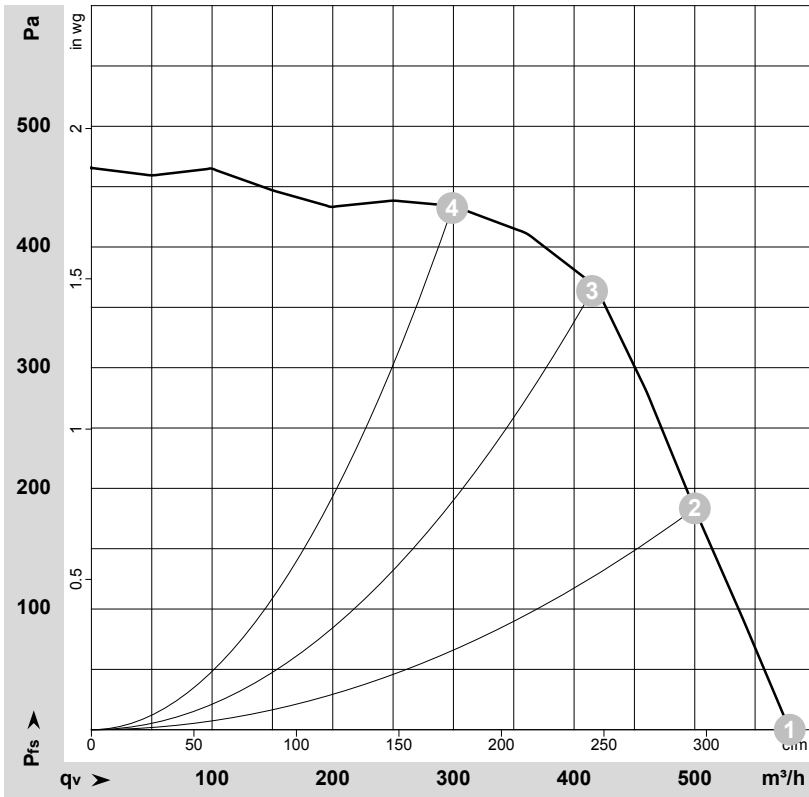

$\rho = 1.15 \text{ kg/m}^3 \pm 2 \%$

Measurement: LU-184795-1

Air performance measured according to ISO 5801 installation category A. For detailed information on the measurement setup, contact ebmpapst. Intake sound level: Sound power level according to ISO 13347 / sound pressure level measured at 1 m distance from fan axis. The values given are valid under the specified measuring conditions and may vary due to conditions of installation. For deviations from the standard configuration, the parameters have to be checked on the installed unit.

## Measured values

	U	f	n	P <sub>ed</sub>	I	LpA <sub>in</sub>	LwA <sub>in</sub>	q <sub>v</sub>	p <sub>fs</sub>	q <sub>v</sub>	p <sub>fs</sub>
	V	Hz	min <sup>-1</sup>	W	A	dB(A)	dB(A)	m <sup>3</sup> /h	Pa	cfm	in. wg
1	230	50	1840	115	1.00	69	75	580	0	340	0.00
2	230	50	2080	115	1.00	67	74	500	180	295	0.72
3	230	50	2305	113	0.95	66	73	415	370	245	1.49
4	230	50	2430	90	0.77	65	72	300	430	175	1.73

U = Power supply · f = Frequency · n = Speed (rpm) · P<sub>ed</sub> = Power consumption · I = Current draw · LpA<sub>in</sub> = Sound pressure level intake side · LwA<sub>in</sub> = Sound power level intake side  
 q<sub>v</sub> = Air flow · p<sub>fs</sub> = Pressure increase

