

R3G160-AZ09-01 ebmpapst Datasheet

sales@fansco.com

www.fansco.com

Limited partnership · Headquarters Muldingen

Amtsgericht (court of registration) Stuttgart · HRA 590344

General partner Elektrobau Muldingen GmbH · Headquarters Muldingen

Amtsgericht (court of registration) Stuttgart · HRB 590142



## Nominal data

<b>Type</b>	<b>R3G160-AZ09-01</b>	
<b>Motor</b>	<b>M3G055-DF</b>	
Phase		1~
Nominal voltage	VAC	230
Nominal voltage range	VAC	200 .. 240
Frequency	Hz	50/60
Method of obtaining data		fa
Speed (rpm)	min <sup>-1</sup>	2000
Power consumption	W	165
Current draw	A	1.3
Min. back pressure	Pa	0
Min. back pressure	inH <sub>2</sub> O	0
Min. ambient temperature	°C	-25
Max. ambient temperature	°C	60

ml = Max. load · me = Max. efficiency · fa = Free air · cs = Customer specification · ce = Customer equipment  
Subject to change

## Data according to ErP Directive

		Actual	Req. 2015		
01 Overall efficiency $\eta_{es}$	%	46.9	32.1	09 Power consumption $P_{ed}$	kW
02 Measurement category		A		09 Air flow $q_v$	m <sup>3</sup> /h
03 Efficiency category		Static		09 Pressure increase $p_{fs}$	Pa
04 Efficiency grade N		58.8	44	10 Speed (rpm) n	min <sup>-1</sup>
05 Variable speed drive		Yes		11 Specific ratio*	

Data obtained at optimum efficiency level.

The ErP data is determined using a motor-impeller combination in a standardized measurement setup.

\* Specific ratio =  $1 + p_s / 100\,000\text{ Pa}$

LU-138657



## Technical description

Fan size	160 mm
Impeller material	Sheet steel, galvanized
Direction of rotation	Clockwise, viewed toward rotor
Degree of protection	IP54
Insulation class	"B"
Max. permitted ambient temp. for motor (transport/storage)	+ 80 °C
Min. permitted ambient temp. for motor (transport/storage)	- 40 °C
Installation position	Any
Condensation drainage holes	None, open rotor
Mode	S1
Motor bearing	Ball bearing
Technical features	<ul style="list-style-type: none"> <li>- Output 10 VDC, max. 10 mA</li> <li>- Tach output</li> <li>- Power limiter</li> <li>- Motor current limitation</li> <li>- Soft start</li> <li>- Control input 0-10 VDC / PWM</li> <li>- Control interface with SELV potential safely disconnected from the mains</li> <li>- Overvoltage detection</li> <li>- Thermal overload protection for electronics/motor</li> <li>- Line undervoltage detection</li> </ul>
Touch current according to IEC 60990 (measuring circuit Fig. 4, TN system)	<= 3.5 mA
Motor protection	Locked-rotor protection
With cable	Variable
Protection class	I (with customer connection of protective earth)
Conformity with standards	EN 60335-1; CE
Approval	CCC; CSA C22.2 No. 77; UL 2111

Product drawing

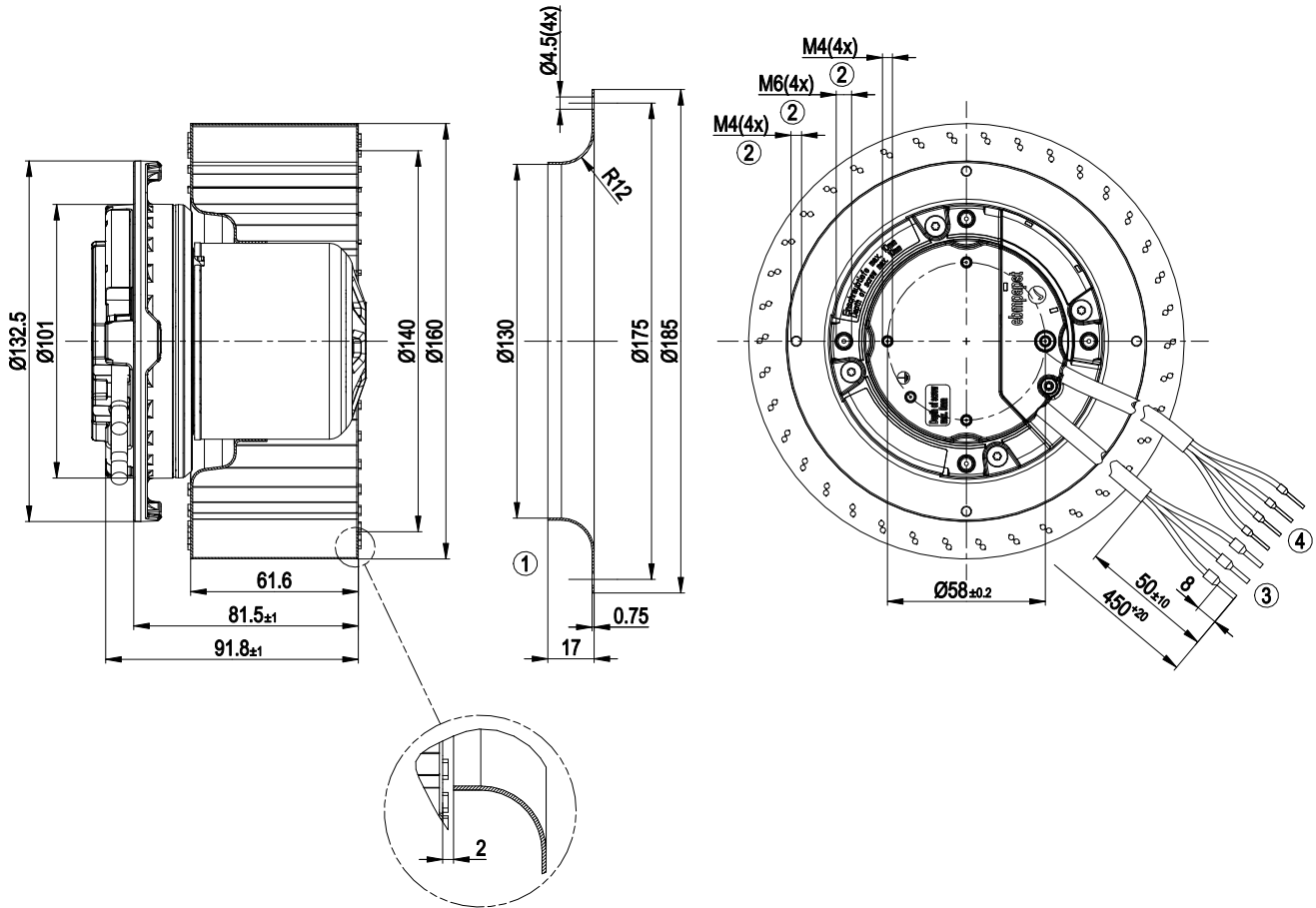

1	Accessory part: Inlet ring: 09588-2-4013 not included in scope of delivery
2	Max. clearance for screw 10 mm
3	Cable PVC 3x AWG22, 3x crimped ferrules
4	Cable PVC 4x AWG20, 4x crimped ferrules



# EC centrifugal fan

forward-curved, single-intake

## Connection diagram

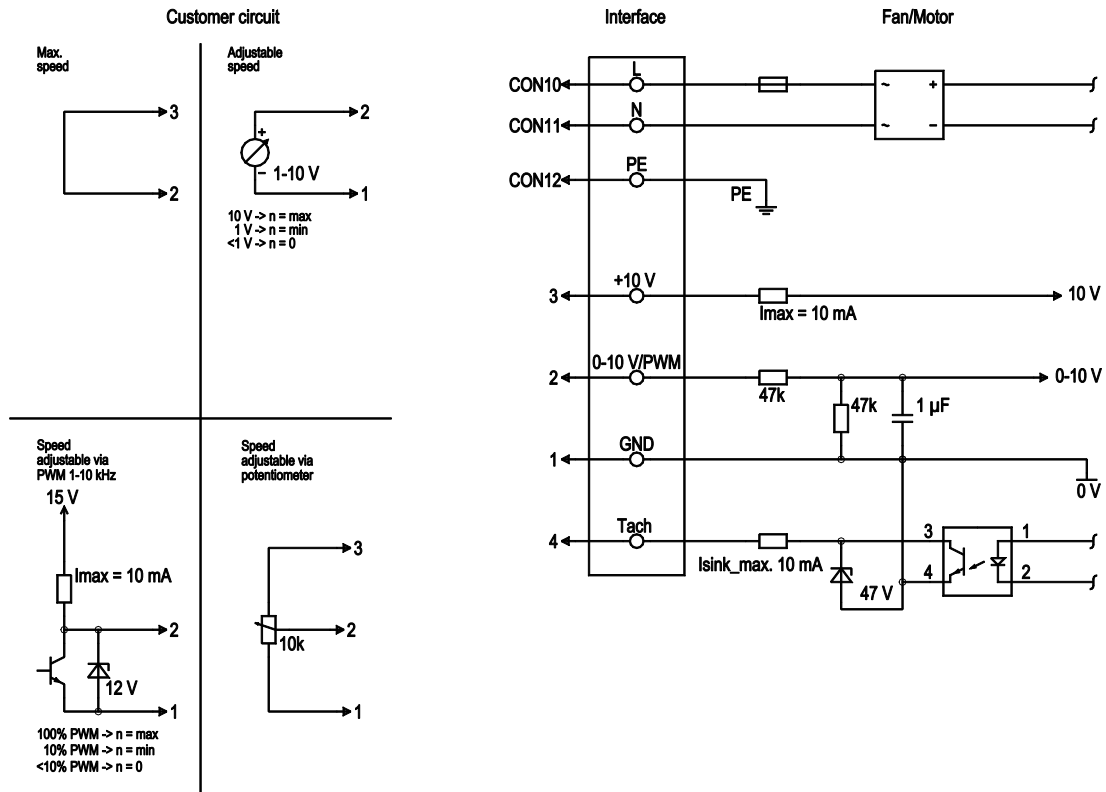

No.	Conn.	Designation	Color	Function/assignment
	CON10	L	black	Supply connection, power supply, phase, see nameplate for voltage range
	CON11	N	blue	Supply connection, power supply, neutral conductor, see nameplate for voltage range
	CON12	PE	green/yellow	Ground connection
	2	0- 10V PWM	yellow	0-10 V / PWM control input, R <sub>i</sub> =100 kΩ, SELV
	4	Tach	white	Tach output, open collector, 1 pulse per revolution, I <sub>sink max</sub> = 10 mA, SELV
	3	+10 V	red	Fixed voltage output 10 VDC +/-3 %, I <sub>max</sub> . 10 mA, short-circuit-proof, power supply for ext. devices (e.g. pot), SELV
	1	GND	blue	Reference ground for control interface, SELV



## Curves: Air performance 50 Hz

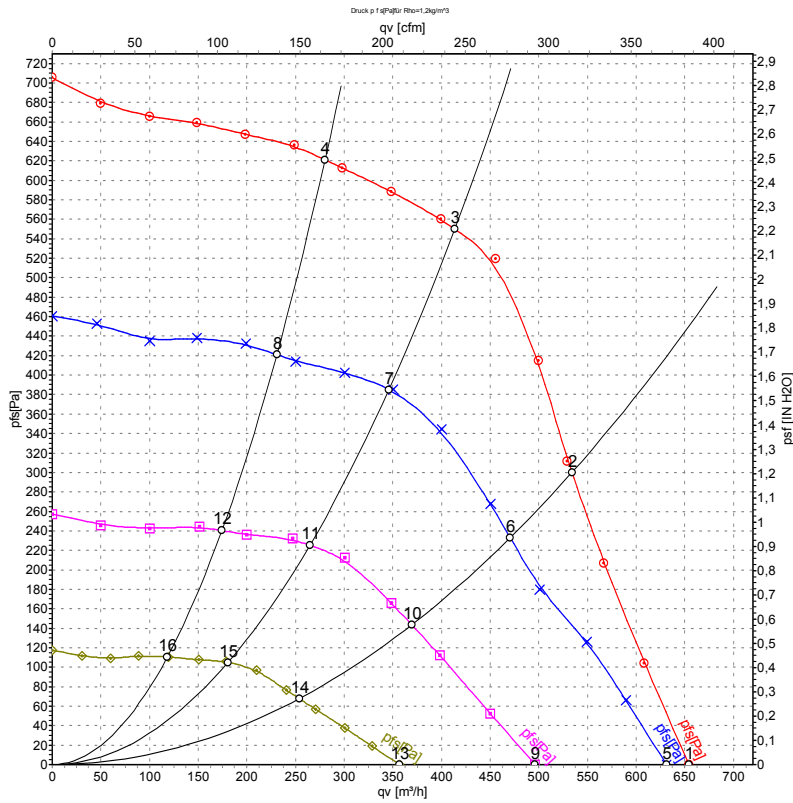

Measurement: LU-138657-1  
 Measurement: LU-138670-1  
 Measurement: LU-138672-1  
 Measurement: LU-138673-1

Air performance measured according to ISO 5801 installation category A. For detailed information on the measurement setup, contact ebmpapst. Intake sound level: Sound power level according to ISO 13347 / sound pressure level measured at 1 m distance from fan axis. The values given are valid under the specified measuring conditions and may vary due to conditions of installation. For deviations from the standard configuration, the parameters have to be checked on the installed unit.

## Measured values

	U	f	n	P <sub>ed</sub>	I	LpA <sub>in</sub>	LwA <sub>in</sub>	qv	p <sub>fs</sub>	qv	p <sub>fs</sub>
	V	Hz	min <sup>-1</sup>	W	A	dB(A)	dB(A)	m <sup>3</sup> /h	Pa	CFM	inH <sub>2</sub> O
1	230	50	2000	165	1.30	69	76	655	0	385	0.00
2	230	50	2370	165	1.30	69	75	535	300	315	1.20
3	230	50	2665	155	1.22	68	74	415	550	245	2.21
4	230	50	2845	116	0.96	69	76	280	620	165	2.49
5	230	50	1925	154	1.24			630	0	370	0.00
6	230	50	2110	117	0.99			470	233	275	0.94
7	230	50	2240	91	0.78			345	387	205	1.55
8	230	50	2350	70	0.62			230	421	135	1.69
9	230	50	1535	76	0.65			495	0	290	0.00
10	230	50	1665	57	0.51			370	144	220	0.58
11	230	50	1745	43	0.38			265	226	155	0.91
12	230	50	1800	34	0.30			175	240	100	0.96
13	230	50	1105	29	0.31			355	0	210	0.00
14	230	50	1160	22	0.21			255	68	150	0.27
15	230	50	1205	17	0.17			180	106	105	0.43
16	230	50	1240	13	0.14			120	111	70	0.45

U = Power supply · f = Frequency · n = Speed (rpm) · P<sub>ed</sub> = Power consumption · I = Current draw · LpA<sub>in</sub> = Sound pressure level intake side · LwA<sub>in</sub> = Sound power level intake side  
 qv = Air flow · p<sub>fs</sub> = Pressure increase

