

R3G133-AE07-22 ebmpapst Datasheet

sales@fansco.com

www.fansco.com

Nominal data

Type	R3G133-AE07-22	
Motor	M3G055-BD	
Phase		1~
Nominal voltage	VAC	230
Nominal voltage range	VAC	200 .. 240
Frequency	Hz	50/60
Method of obtaining data		ml
Speed (rpm)	min ⁻¹	4320
Power consumption	W	50
Current draw	A	0.46
Min. ambient temperature	°C	-25
Max. ambient temperature	°C	60

ml = Max. load · me = Max. efficiency · fa = Free air · cs = Customer specification · ce = Customer equipment
Subject to change



Technical description

Weight	1.094 kg
Size	133 mm
Motor size	55
Rotor surface	Thick-film passivated
Impeller material	PA plastic
Number of blades	7
Direction of rotation	Clockwise, viewed toward rotor
Degree of protection	IP54
Insulation class	"B"
Moisture (F) / Environmental (H) protection class	H1
Max. permitted ambient temp. for motor (transport/storage)	+ 80 °C
Min. permitted ambient temp. for motor (transport/storage)	- 40 °C
Installation position	Any
Condensation drainage holes	None, open rotor
Mode	S1
Motor bearing	Ball bearing
Technical features	<ul style="list-style-type: none"> - Output 10 VDC, max. 10 mA - Tach output - Power limiter - Motor current limitation - Soft start - Control input 0-10 VDC / PWM - Control interface with SELV potential safely disconnected from the mains - Overvoltage detection - Thermal overload protection for electronics/motor - Line undervoltage detection
EMC immunity to interference	According to EN 61000-6-2 (industrial environment)
EMC circuit feedback	According to EN 61000-3-2/3
EMC interference emission	According to EN 61000-6-3 (household environment)
Touch current according to IEC 60990 (measuring circuit Fig. 4, TN system)	<= 3.5 mA
Motor protection	Electronic motor protection
With cable	Variable
Protection class	I (with customer connection of protective earth)
Conformity with standards	EN 60335-1; CE

Product drawing

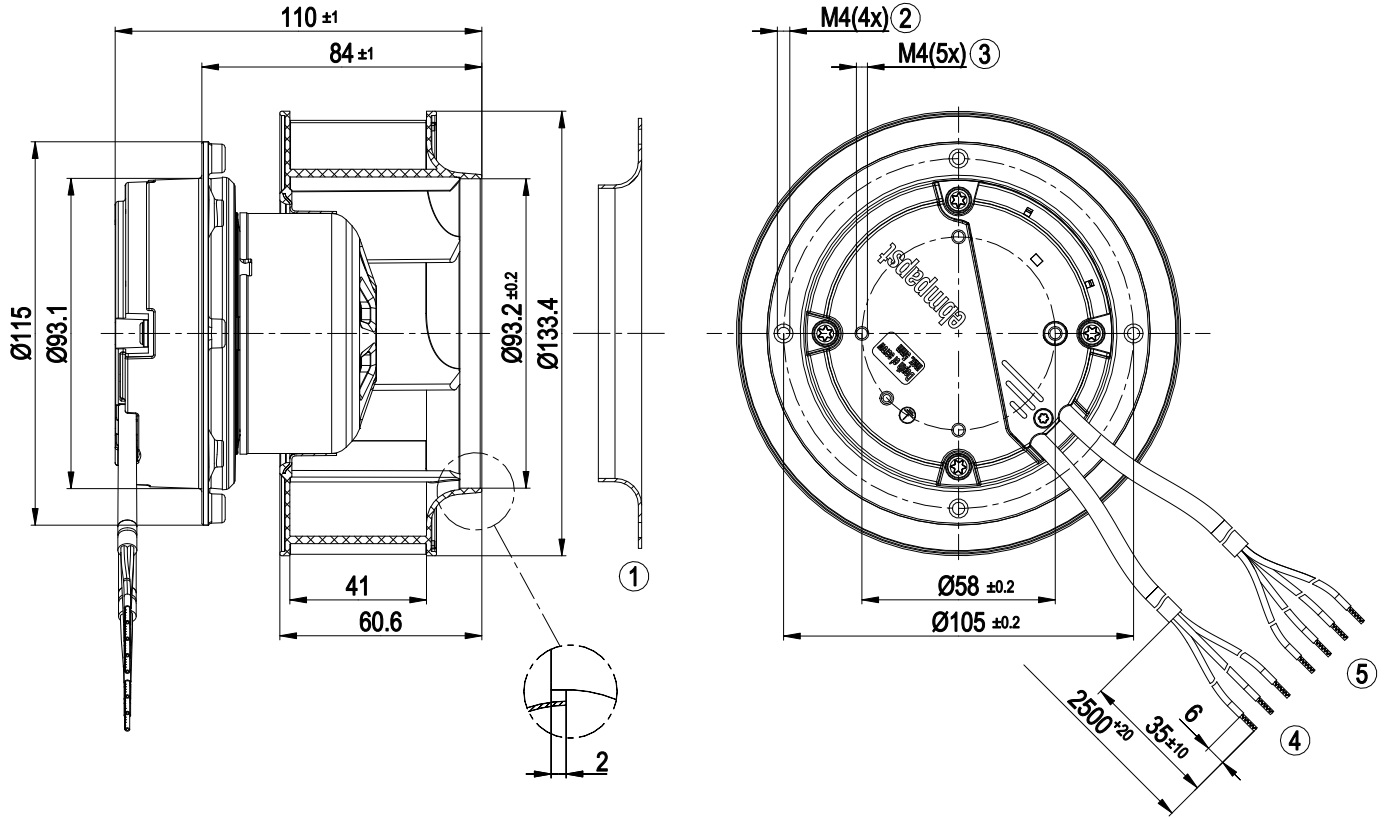

1	Accessory part: Inlet ring 09566-2-4013, not included in scope of delivery
2	Max. clearance for screw 5 mm
3	Max. clearance for screw 5 mm
4	Cable PVC 3G 0.5 mm ² 3x splice
5	Cable PVC 4x 0.25 mm ² 4x splice

EC centrifugal fan

backward-curved, single-intake

Accessory part

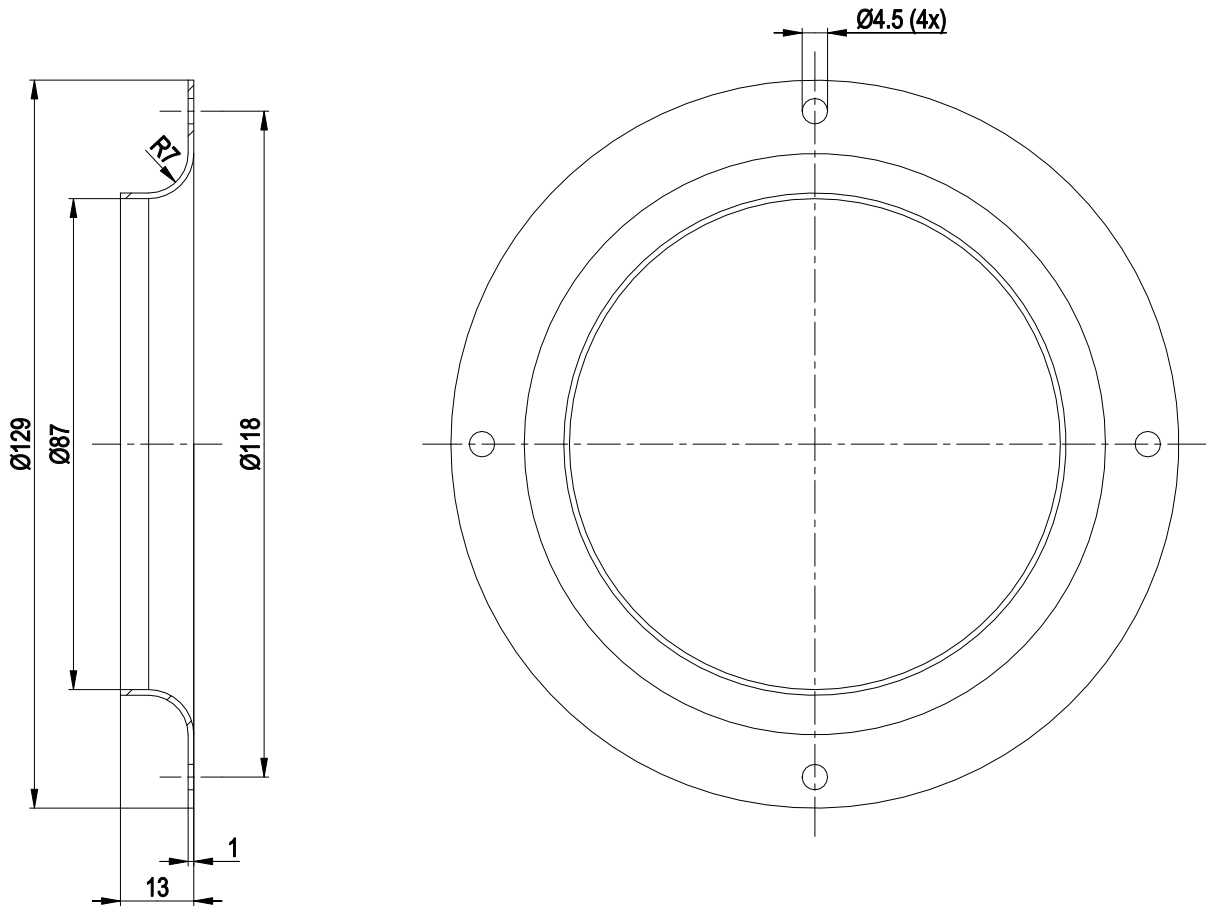

1 Accessory part: inlet ring 09566-2-4013 not included in scope of delivery

Connection diagram

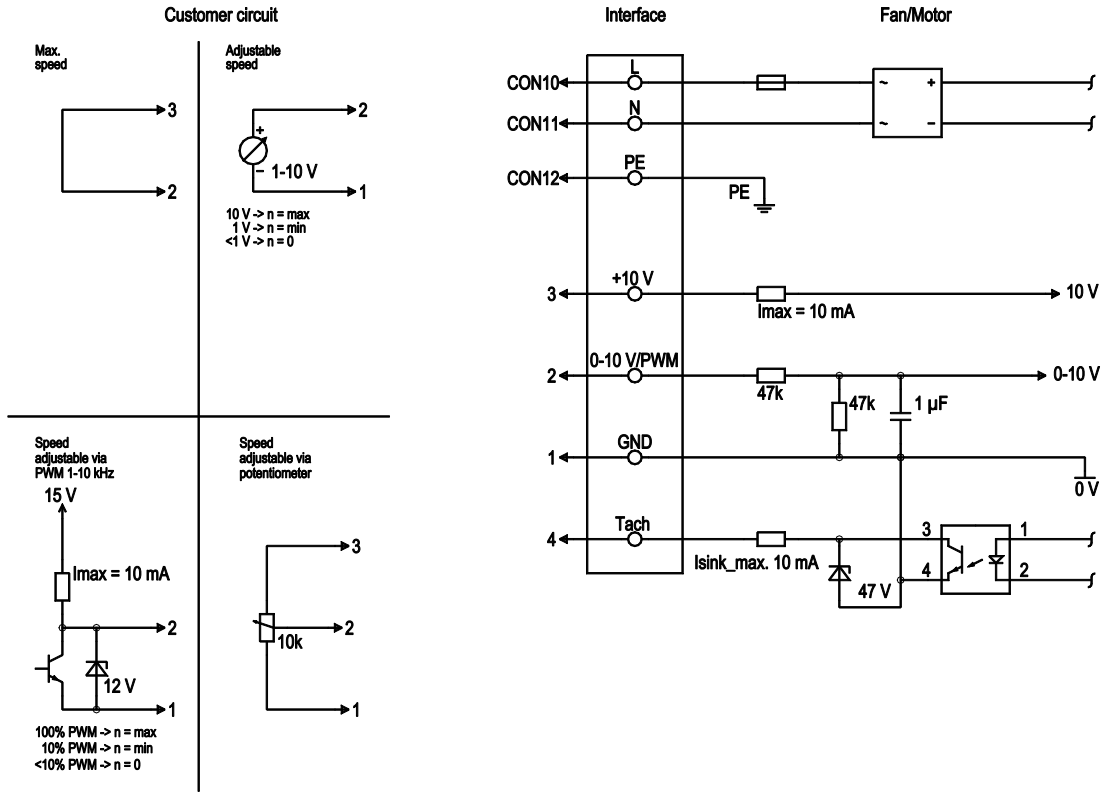

No.	Conn.	Designation	Color	Function/assignment
	CON10	L	brown	Supply connection, power supply, phase, see nameplate for voltage range
	CON11	N	blue	Supply connection, power supply, neutral conductor, see nameplate for voltage range
	CON12	PE	green/yellow	Ground connection
	2	0- 10V PWM	yellow	0-10 V / PWM control input, R _i =100 kΩ, SELV
	4	Tach	white	Tach output, open collector, 1 pulse per revolution, I _{sink max} = 10 mA, SELV
	3	+10 V	red	Fixed voltage output 10 VDC +/-3 %, I _{max} . 10 mA, short-circuit-proof, power supply for ext. devices (e.g. pot), SELV
	1	GND	blue	Reference ground for control interface, SELV

Curves: Air performance 50 Hz

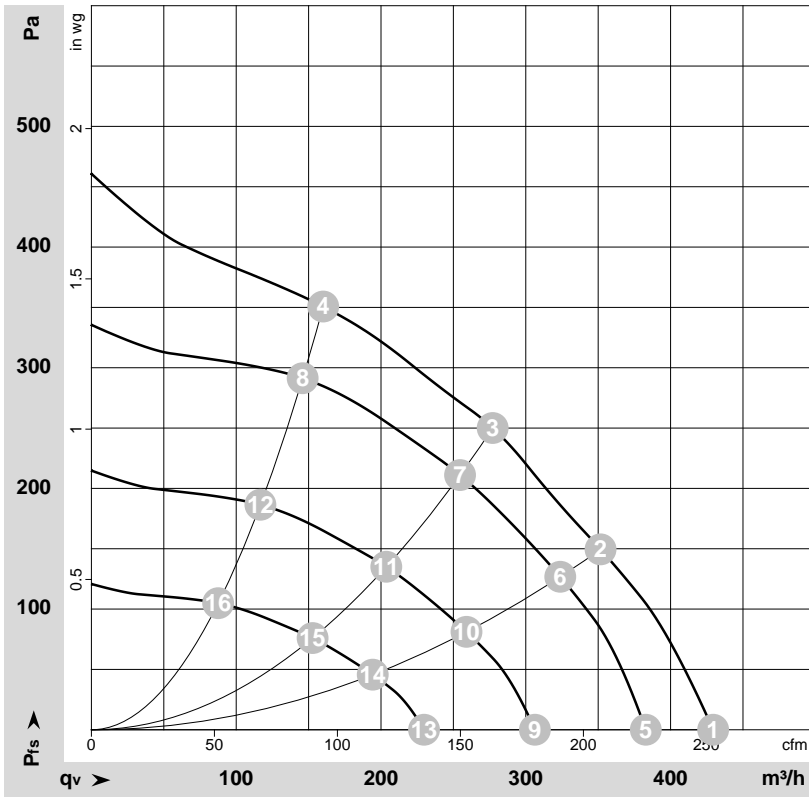

$\rho = 1.15 \text{ kg/m}^3 \pm 2 \%$

Measurement: LU-170319-1

Air performance measured according to ISO 5801 installation category A. For detailed information on the measurement setup, contact ebmpapst. Intake sound level: Sound power level according to ISO 13347 / sound pressure level measured at 1 m distance from fan axis. The values given are valid under the specified measuring conditions and may vary due to conditions of installation. For deviations from the standard configuration, the parameters have to be checked on the installed unit.

Measured values

	U	f	n	P _{ed}	I	LpA _{in}	LwA _{in}	q _v	P _{fs}	q _v	P _{fs}
	V	Hz	min ⁻¹	W	A	dB(A)	dB(A)	m ³ /h	Pa	cfm	in. wg
1	230	50	4485	43	0.35	77	86	430	0	250	0.00
2	230	50	4350	50	0.46	64	76	350	150	205	0.60
3	230	50	4320	50	0.46	59	67	275	250	165	1.00
4	230	50	4385	46	0.40	61	69	160	350	95	1.41
5	230	50	4000	31	0.23	74	83	385	0	225	0.00
6	230	50	4000	39	0.30	62	74	325	127	190	0.51
7	230	50	4000	37	0.29	57	65	255	212	150	0.85
8	230	50	4000	35	0.27	59	67	145	292	85	1.17
9	230	50	3200	16	0.12	69	77	305	0	180	0.00
10	230	50	3200	20	0.15	57	69	260	81	150	0.33
11	230	50	3200	19	0.15	51	59	205	136	120	0.55
12	230	50	3200	18	0.14	53	61	115	187	70	0.75
13	230	50	2400	7.0	0.05	62	70	230	0	135	0.00
14	230	50	2400	8.0	0.06	49	61	195	46	115	0.18
15	230	50	2400	8.0	0.06	44	52	155	76	90	0.31
16	230	50	2400	8.0	0.06	46	54	90	105	50	0.42

U = Voltage · f = Frequency · n = Speed (rpm) · P_{ed} = Power consumption · I = Current draw · LpA_{in} = Sound pressure level intake side · LwA_{in} = Sound power level intake side
 q_v = Air flow · P_{fs} = Pressure increase

