

EC centrifugal fan

backward curved

R3G133-AE07-11 ebmpapst Datasheet

sales@fansco.com

www.fansco.com

Limited partnership · Headquarters Muldingen
County court Stuttgart · HRA 590344

General partner Elektrobau Muldingen GmbH · Headquarters Muldingen
County court Stuttgart · HRB 590142

Nominal data

Type	R3G133-AE07-11	
Motor	M3G055-BD	
Phase		1~
Nominal voltage	VAC	230
Frequency	Hz	50/60
Type of data definition		fa
Speed (rpm)	min ⁻¹	4480
Power input	W	43
Current draw	A	0.32
Min. ambient temperature	°C	-25
Max. ambient temperature	°C	60

ml = Max. load · me = Max. efficiency · fa = Running at free air · cs = Customer specs · cu = Customer unit
Subject to alterations



Technical features

Mass	1.0 kg
Size	133 mm
Surface of rotor	Thick layer passivated
Material of electronics housing	Die-cast aluminium
Material of impeller	PA plastic
Number of blades	7
Direction of rotation	Clockwise, seen on rotor
Type of protection	IP 44
Insulation class	"B"
Humidity (F)/environmental protection class (H)	F3-1
Max. permissible ambient motor temp. (transp./ storage)	+ 80 °C
Min. permissible ambient motor temp. (transp./storage)	- 40 °C
Mounting position	Any
Condensate discharge holes	Rotor-side
Operation mode	S1
Motor bearing	Ball bearing
Technical features	<ul style="list-style-type: none"> - Output 10 VDC, max. 1.1 mA - Tach output - Motor current limit - Soft start - Control input 0-10 VDC / PWM - Control interface with SELV potential safely disconnected from the mains - Over-temperature protected motor
EMC interference immunity	Acc. to EN 61000-6-2 (industrial environment)
EMC harmonics	Acc. to EN 61000-3-2/3
EMC interference emission	Acc. to EN 61000-6-3 (household environment)
Touch current acc. IEC 60990 (measuring network Fig. 4, TN system)	<= 3.5 mA
Motor protection	Thermal overload protector (TOP) wired internally
Cable exit	Variable
Protection class	I (if protective earth is connected by customer)
Product conforming to standard	EN 60335-1
Approval	EAC

Product drawing

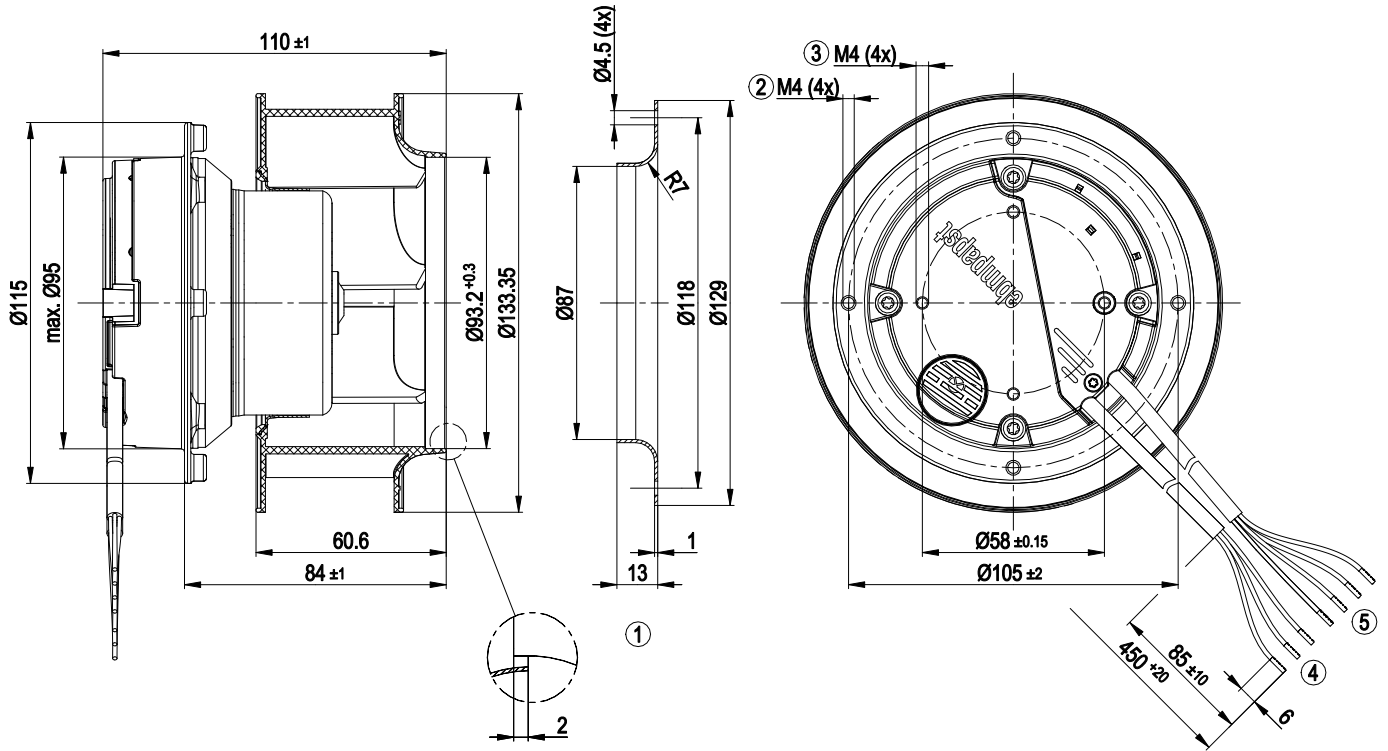

1	Accessory part: Inlet nozzle 09566-2-4013, not included in the standard scope of delivery
2	Depth of screw max. 6 mm
3	Depth of screw max. 6 mm
4	Connection line PVC 3G 0.5 mm ² , 3x brass lead tips crimped
5	Connection line PVC 4x 0.25 mm ² ; 4 x brass lead tips crimped

Connection screen

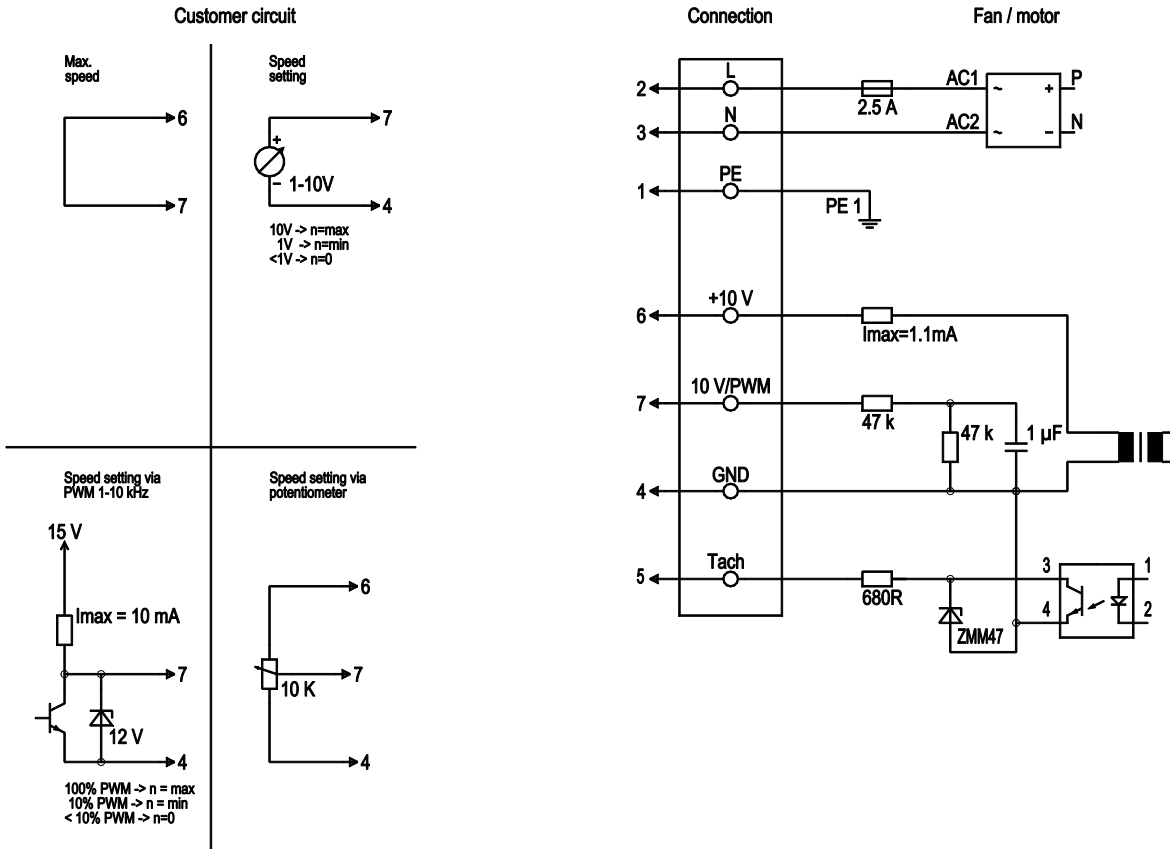

No.	Conn.	Designation	Colour	Function / assignment
	2	L	brown	Power supply 230 VAC, 50-60 Hz, see type plate for voltage range
	3	N	blue	Neutral conductor
	1	PE	green/yellow	Protective earth
	7	0-10 V PWM	yellow	Control input 0 - 10 V or PWM, electrically isolated
	5	Tach	white	Tach output: Open Collector, 1 pulse per revolution, electrically isolated
	6	10V / max. 1.1 mA	red	Voltage output 10V / 1.1mA, electrically isolated, not short-circuit-proof
	4	GND	blue	GND - Connection for control interface

Charts: Air flow 50 Hz

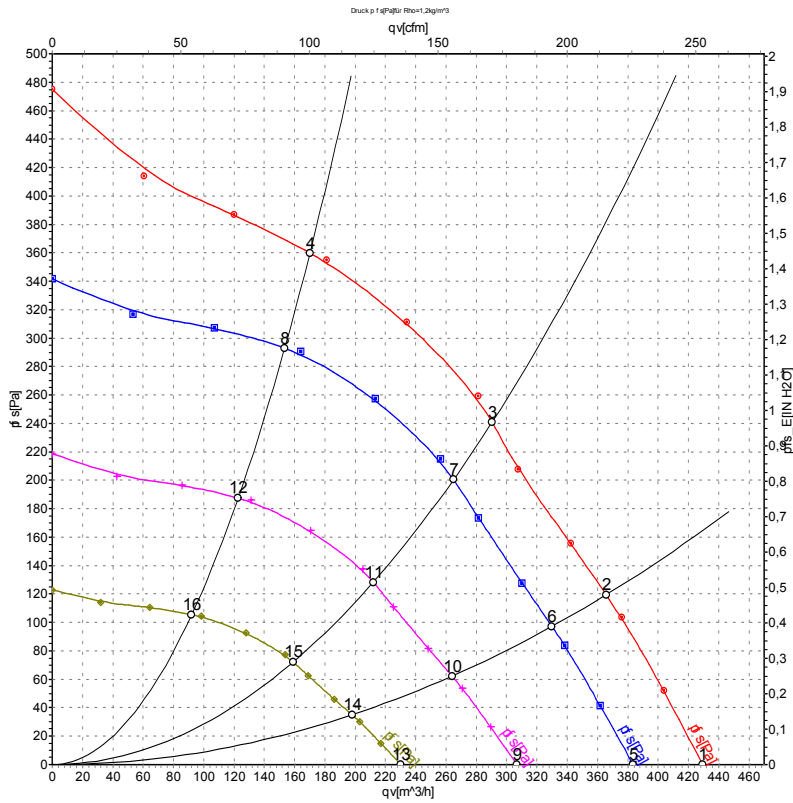

Measurement: LU-68538-1

Air performance measured as per ISO 5801 Installation category A. For detailed information on the measuring set-up, please contact ebm-papst. Suction-side noise levels: LwA measured as per ISO 13347 / LpA measured with 1m distance to fan axis. The values given are valid under the measuring conditions mentioned above and may vary according to the actual installation situation. With any deviation from the standard set-up, the specific values have to be checked and reviewed with the unit installed.

Measured values

	U	f	n	P _{ed}	I	q _v	P _{fs}	q _v	P _{fs}
	V	Hz	min ⁻¹	W	A	m ³ /h	Pa	cfm	inH2O
1	230	50	4480	43	0.32	430	0	255	0.00
2	230	50	4435	47	0.35	365	120	215	0.48
3	230	50	4385	49	0.38	290	240	170	0.96
4	230	50	4430	47	0.36	170	360	100	1.45
5	230	50	4000	31	0.23	385	0	225	0.00
6	230	50	4000	35	0.26	330	97	195	0.39
7	230	50	4000	38	0.29	265	201	155	0.81
8	230	50	4000	34	0.26	155	294	90	1.18
9	230	50	3200	16	0.12	305	0	180	0.00
10	230	50	3200	18	0.13	265	62	155	0.25
11	230	50	3200	19	0.15	210	128	125	0.51
12	230	50	3200	18	0.14	125	188	70	0.75
13	230	50	2400	6.6	0.05	230	0	135	0.00
14	230	50	2400	7.5	0.06	200	35	115	0.14
15	230	50	2400	8.1	0.06	160	72	95	0.29
16	230	50	2400	7.4	0.06	90	106	55	0.43

U = Supply voltage · f = Frequency · n = Speed (rpm) · P_{ed} = Power input · I = Current draw · q_v = Air flow · P_{fs} = Pressure increase

