

R2E250-RB06-30 ebmpapst Datasheet

sales@fansco.com

www.fansco.com

Limited partnership · Headquarters Muldingen
County court Stuttgart · HRA 590344General partner Elektrobau Muldingen GmbH · Headquarters Muldingen
County court Stuttgart · HRB 590142

Nominal data

Type	R2E250-RB06-30		
Motor	M2E074-EI		
Phase		1~	1~
Nominal voltage	VAC	230	230
Frequency	Hz	50	60
Type of data definition		ml	ml
Valid for approval / standard		CE	CE
Speed (rpm)	min ⁻¹	2750	3100
Power input	W	250	390
Current draw	A	1.1	1.71
Motor capacitor	µF	5	5
Capacitor voltage	VDB	450	450
Min. back pressure	Pa	0	0
Min. ambient temperature	°C	-25	-25
Max. ambient temperature	°C	75	65
Starting current	A	3.15	3.0

ml = Max. load · me = Max. efficiency · fa = Running at free air · cs = Customer specs · cu = Customer unit
Subject to alterations

Data in accordance with ecodesign regulation EU 327/2011

		Actual	Request 2015			
01 Overall efficiency η_{es}	%	45	45	09 Power input P_e	kW	0.24
02 Measurement category		A		09 Air flow q_v	m ³ /h	900
03 Efficiency category		Static		09 Pressure increase p_{fs}	Pa	439
04 Efficiency grade N		62	62	10 Speed (rpm) n	min ⁻¹	2775
05 Variable speed drive		No		11 Specific ratio*		1.00

Data definition with optimum efficiency.
The ErP data is determined using a motor-impeller combination in a standardised measurement configuration.* Specific ratio = $1 + p_{fs} / 100\,000\text{ Pa}$

LU-130850



Technical features

Mass	3.9 kg
Size	250 mm
Surface of rotor	Coated in black
Material of impeller	PA plastic
Number of blades	7
Direction of rotation	Clockwise, seen on rotor
Type of protection	IP 44; Depending on installation and position as per EN 60034-5
Insulation class	"F"
Humidity (F)/environmental protection class (H)	H0+
Max. permissible ambient motor temp. (transp./ storage)	+ 80 °C
Min. permissible ambient motor temp. (transp./storage)	- 40 °C
Mounting position	Shaft horizontal or rotor on bottom; rotor on top on request
Condensate discharge holes	Rotor-side
Operation mode	S1
Motor bearing	Ball bearing
Technical features	- Speed monitoring Hall IC
Touch current acc. IEC 60990 (measuring network Fig. 4, TN system)	< 0.75 mA
Motor protection	Thermal overload protector (TOP) wired internally
Cable exit	Variable
Protection class	I (if protective earth is connected by customer)
Motor capacitor according to EN 60252-1 in safety protection class	S0
Product conforming to standard	EN 60034-1; EN 60204-1; CE
Approval	UL 2111; CSA C22.2 No.77

Product drawing

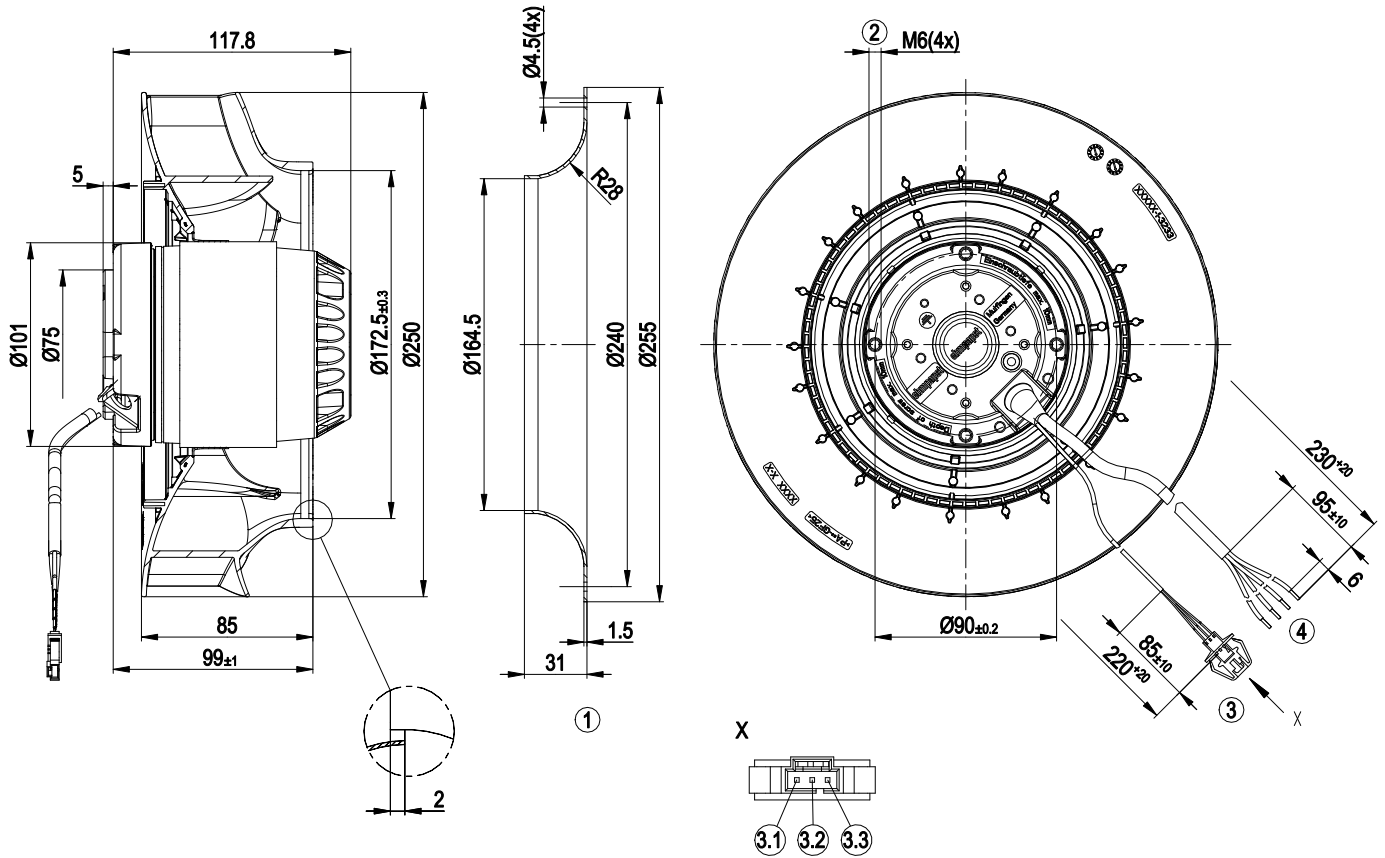

1	Accessory part: inlet nozzle 96359-2-4013, not included in scope of delivery
2	Thread reach max. 10 mm
3	Connection line Raychem Spec. 44, AWG24, connector housing 3-pole Molex 70107-0037, 3x plug pin Molex 16-02-0078
3.1	red (Hall IC)
3.2	white (Hall IC)
3.3	black (Hall IC)
4	Connection line PFA AWG20 (green/yellow AWG18), 4x lead tips crimped

Connection screen

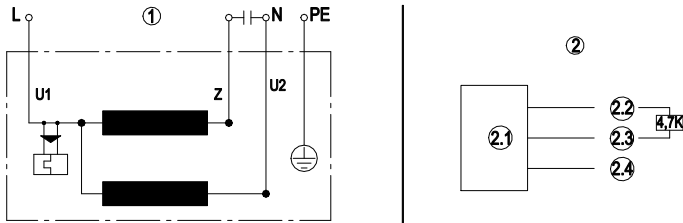

1	Fan connection diagram
U1	Blue
Z	brown
U2	black
PE	green/yellow
2	Hall IC circuit
2.1	Hall IC
2.2	Red (+5V)
2.3	White (out)
2.4	Black (0V)

Charts: Air flow 50 Hz

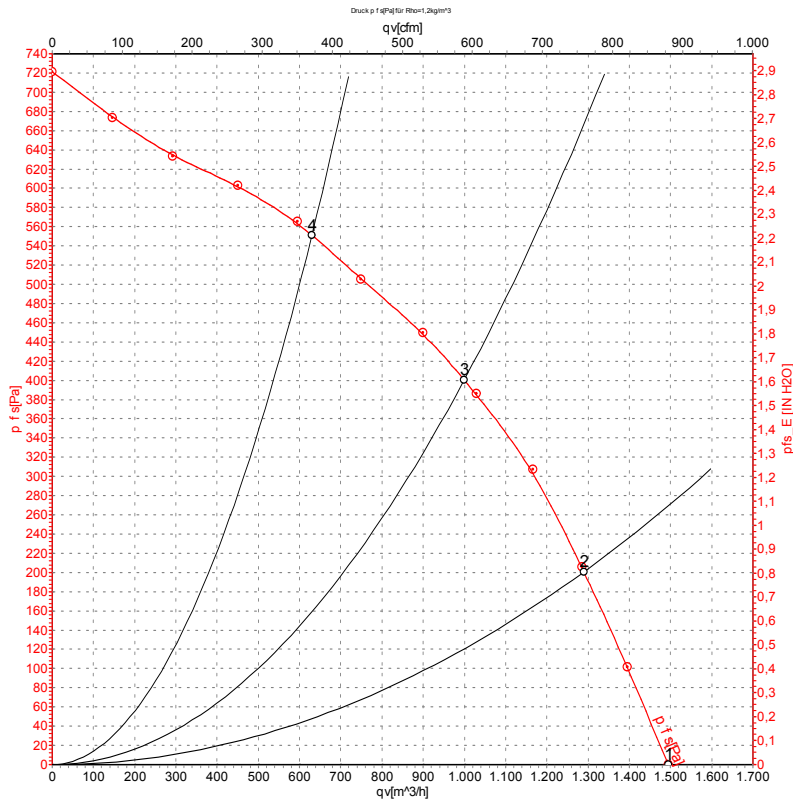

Measurement: LU-130850-1

Air performance measured as per ISO 5801 Installation category A. For detailed information on the measuring set-up, please contact ebm-papst. Suction-side noise levels: LwA measured as per ISO 13347 / LpA measured with 1m distance to fan axis. The values given are valid under the measuring conditions mentioned above and may vary according to the actual installation situation. With any deviation from the standard set-up, the specific values have to be checked and reviewed with the unit installed.

Measured values

	U	f	n	P _e	I	LpA _{in}	LwA _{in}	q _v	P _{fs}	q _v	P _{fs}
	V	Hz	min ⁻¹	W	A	dB(A)	dB(A)	m ³ /h	Pa	cfm	inH ₂ O
1	230	50	2800	215	0.95	69	78	1495	0	880	0.00
2	230	50	2790	237	1.03	65	74	1290	200	760	0.80
3	230	50	2750	250	1.10	62	71	1000	400	590	1.61
4	230	50	2800	227	0.99	66	74	630	550	370	2.21

U = Supply voltage · f = Frequency · n = Speed (rpm) · P_e = Power input · I = Current draw · LpA_{in} = Sound pressure level inlet side · LwA_{in} = Sound power level inlet side · q_v = Air flow
 P_{fs} = Pressure increase



Charts: Air flow 60 Hz

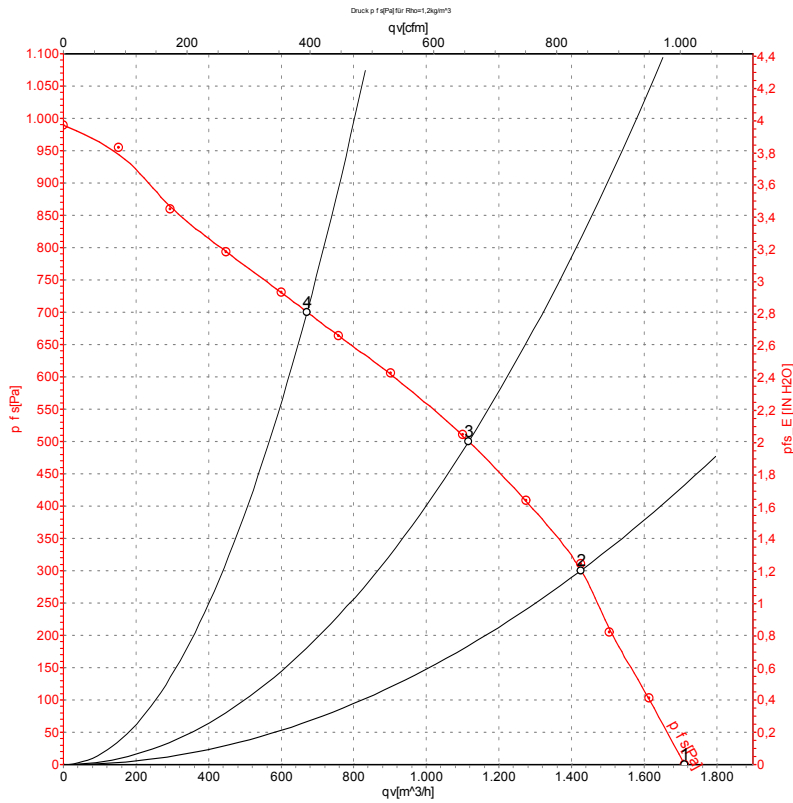

Measurement: LU-130856-1

Air performance measured as per ISO 5801 Installation category A. For detailed information on the measuring set-up, please contact ebm-papst. Suction-side noise levels: L_{wA} measured as per ISO 13347 / L_{pA} measured with 1m distance to fan axis. The values given are valid under the measuring conditions mentioned above and may vary according to the actual installation situation. With any deviation from the standard set-up, the specific values have to be checked and reviewed with the unit installed.

Measured values

	U	f	n	P _e	I	LpA _{in}	LwA _{in}	q _v	P _{fs}	q _v	P _{fs}
	V	Hz	min ⁻¹	W	A	dB(A)	dB(A)	m ³ /h	Pa	cfm	inH2O
1	230	60	3200	345	1.51	73	81	1710	0	1005	0.00
2	230	60	3155	364	1.59	67	76	1425	300	840	1.20
3	230	60	3100	390	1.71	65	73	1115	500	655	2.01
4	230	60	3150	365	1.59	70	80	670	700	395	2.81

U = Supply voltage · f = Frequency · n = Speed (rpm) · P_e = Power input · I = Current draw · LpA_{in} = Sound pressure level inlet side · LwA_{in} = Sound power level inlet side · q_v = Air flow
 P_{fs} = Pressure increase

