

R2E225-RA92-23/A01

# AC centrifugal fan

backward curved, single inlet



R2E225-RA92-23/A01 ebmpapst Datasheet

sales@fansco.com

www.fansco.com

Limited partnership · Headquarters Muldingen  
County court Stuttgart · HRA 590344

General partner Elektrobau Muldingen GmbH · Headquarters Muldingen  
County court Stuttgart · HRB 590142



## Nominal data

<b>Type</b>	R2E225-RA92-23/A01		
<b>Motor</b>	M2E068-DF		
Phase		1~	1~
Nominal voltage	VAC	230	230
Frequency	Hz	50	60
Type of data definition		ml	ml
Speed	min <sup>-1</sup>	2550	2740
Power input	W	150	220
Current draw	A	0.66	0.96
Motor capacitor	µF	4/3.5	4/3.5
Capacitor voltage	VDB	450	450
Capacitor standard			
Min. back pressure	Pa	0	0
Min. ambient temperature	°C	-25	-25
Max. ambient temperature	°C	70	65
Starting current	A	1.25	1.2

ml = Max. load · me = Max. efficiency · fa = Running at free air · cs = Customer specs · cu = Customer unit  
Subject to alterations

## Data according to ErP directive

Installation category	A
Efficiency category	Static
Variable speed drive	No
Specific ratio*	1.00

\* Specific ratio =  $1 + p_b / 100\,000\text{ Pa}$

		Actual	Request 2013	Request 2015
Overall efficiency $\eta_{es}$	%	42.5	38.5	42.5
Efficiency grade N		62	58	62
Power input $P_e$	kW	0.14		
Air flow $q_v$	m <sup>3</sup> /h	705		
Pressure increase $p_{fs}$	Pa	320		
Speed n	min <sup>-1</sup>	2560		

Data definition with optimum efficiency. LU-127147  
The ErP data is determined using a motor-impeller combination in a standardised measurement configuration.



### Technical features

<b>Mass</b>	2.4 kg
<b>Size</b>	225 mm
<b>Surface of rotor</b>	Coated in black
<b>Material of impeller</b>	PA plastic
<b>Number of blades</b>	7
<b>Direction of rotation</b>	Clockwise, seen on rotor
<b>Type of protection</b>	IP 44; Depending on installation and position as per EN 60034-5
<b>Insulation class</b>	"F"
<b>Humidity class</b>	F1-2
<b>Max. permissible ambient motor temp. (transp./ storage)</b>	+ 80 °C
<b>Min. permissible ambient motor temp. (transp./storage)</b>	- 40 °C
<b>Mounting position</b>	Shaft horizontal or rotor on bottom; rotor on top on request
<b>Condensate discharge holes</b>	Rotor-side
<b>Operation mode</b>	S1
<b>Motor bearing</b>	Ball bearing
<b>Touch current acc. IEC 60990 (measuring network Fig. 4, TN system)</b>	< 0.75 mA
<b>Motor protection</b>	Thermal overload protector (TOP) wired internally
<b>Cable exit</b>	Variable
<b>Protection class</b>	I (if protective earth is connected by customer)
<b>Product conforming to standard</b>	EN 60335-1; CE
<b>Approval</b>	CSA C22.2 Nr.77; UL 2111



R2E225-RA92-23/A01

# AC centrifugal fan

backward curved, single inlet

## Product drawing

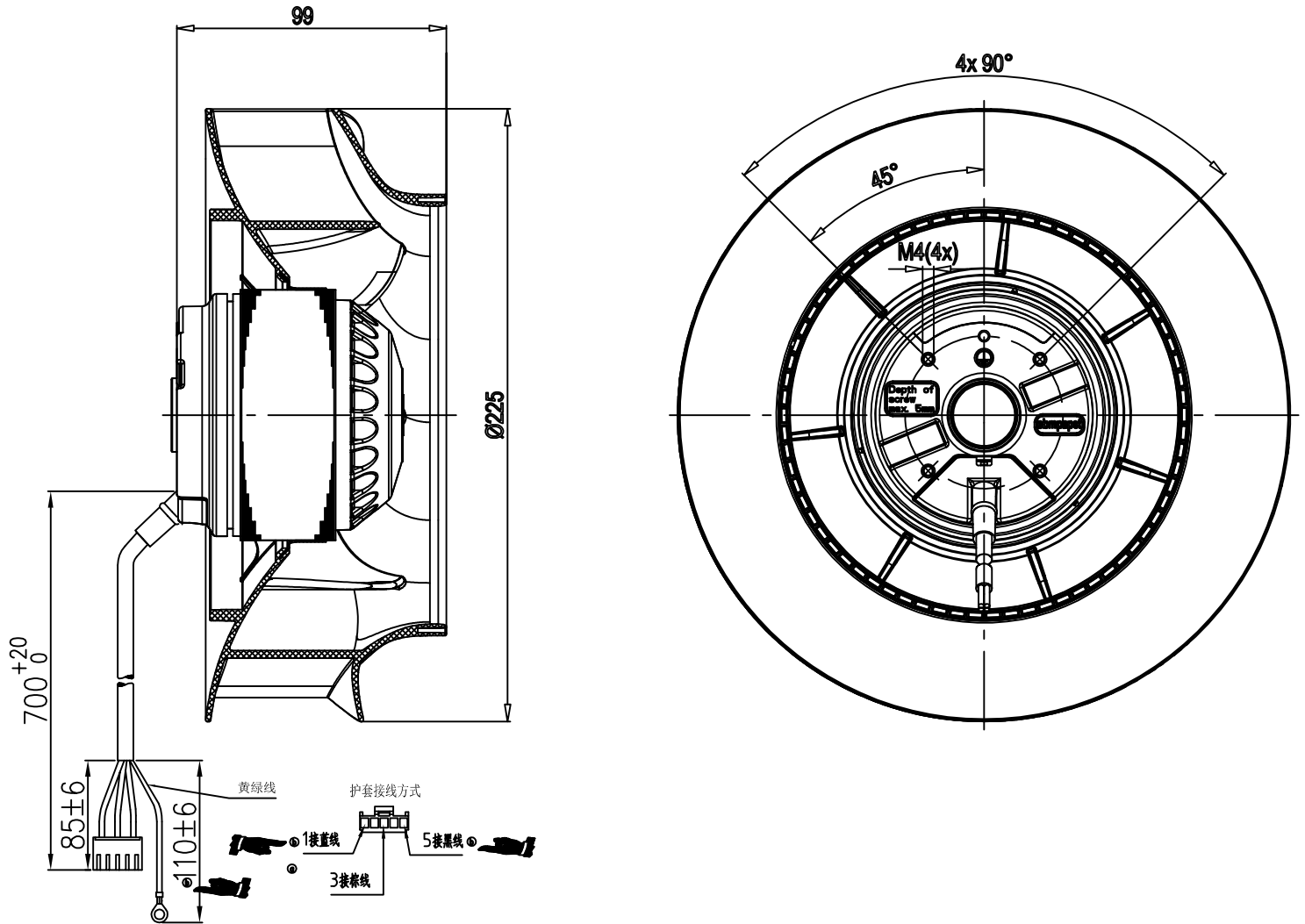

## Connection screen

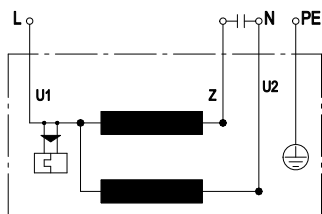

U1	blue	Z	brown	U2	black
PE	green/yellow				



## Charts: Air flow 50 Hz

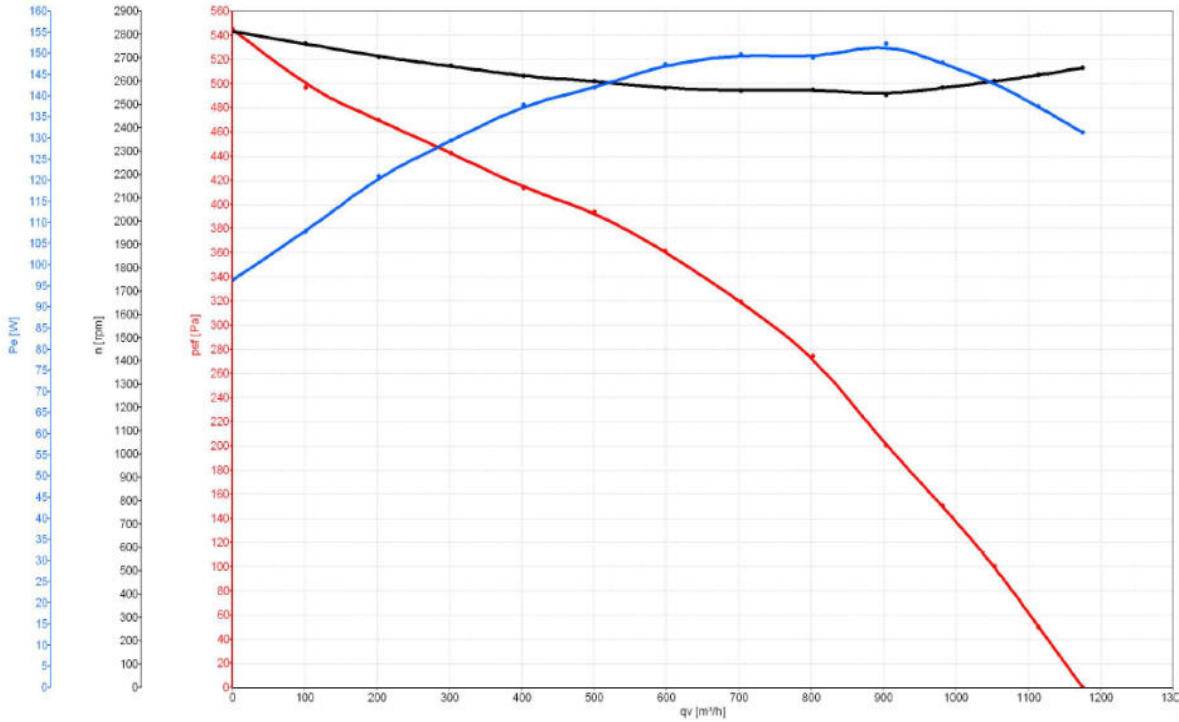

Measurement: LU-154575

Air performance measured as per ISO 5801 Installation category A. For detailed information on the measuring set-up, please contact ebmpapst. Suction-side noise levels: LwA measured as per ISO 13347 / LpA measured with 1m distance to fan axis. The values given are valid under the measuring conditions mentioned above and may vary according to the actual installation situation. With any deviation from the standard set-up, the specific values have to be checked and reviewed with the unit installed.

## Measured values

	U	f	n	Pe	I	LpA <sub>in</sub>	LwA <sub>in</sub>	qv	p <sub>fs</sub>
	V	Hz	min <sup>-1</sup>	W	A	dB(A)	dB(A)	m <sup>3</sup> /h	Pa
1	230	50	2657	131	0.58	65.7	73.5	1176	0
2	230	50	2571	148	0.65	64.4	72	982	150
3	230	50	2558	150	0.65	58	66	703	320
4	230	50	2664	129	0.57	64.8	72.7	302	442

U = Supply voltage · f = Frequency · n = Speed · Pe = Power input · I = Current draw · LpA<sub>in</sub> = Sound pressure level inlet side · LwA<sub>in</sub> = Sound power level inlet side · qv = Air flow  
p<sub>fs</sub> = Pressure increase



## Charts: Air flow 60 Hz

IDNO	Type	U [V]	f [Hz]	C [µF]	Uc [V]	PWM (%)	Layout	Inst. cat.	Line	Remark
127158	R2E225RA92-21D	230	60	4				A	<del>X-X</del>	

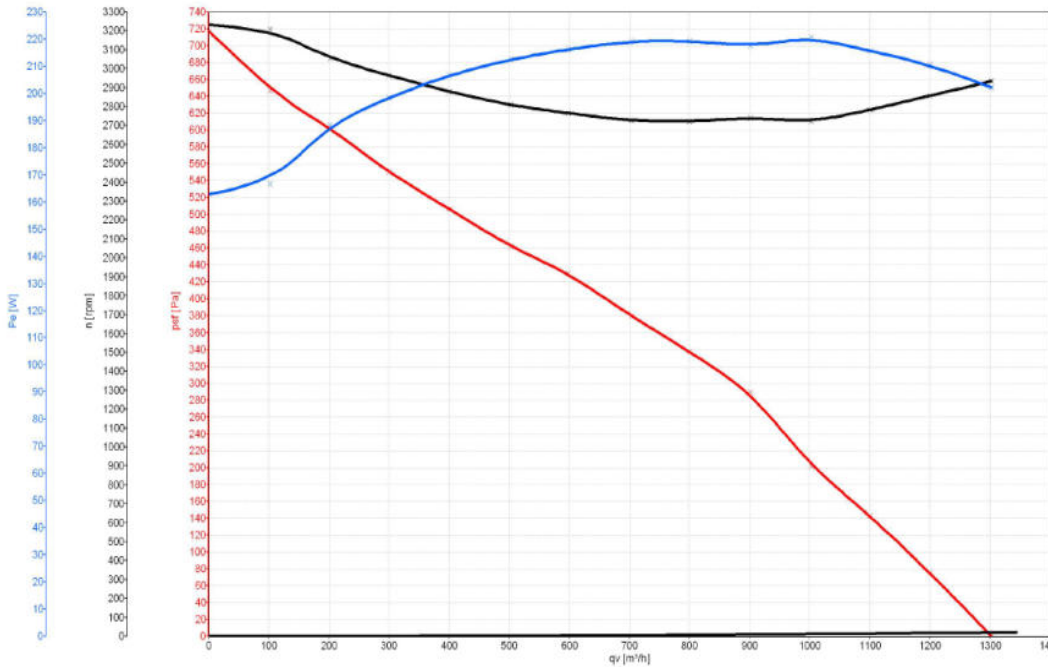

Measurement: LU-127148

Air performance measured as per ISO 5801 Installation category A. For detailed information on the measuring set-up, please contact ebm-papst. Suction-side noise levels: LwA measured as per ISO 13347 / LpA measured with 1m distance to fan axis. The values given are valid under the measuring conditions mentioned above and may vary according to the actual installation situation. With any deviation from the standard set-up, the specific values have to be checked and reviewed with the unit installed.

## Measured values

	U	f	n	Pe	I	qv	Pfs
	V	Hz	min <sup>-1</sup>	W	A	m <sup>3</sup> /h	Pa
1	230	60	2935	202	0.89	1302	0
2	230	60	2720	220	0.96	1002	202
3	230	60	2721	219	0.96	800	338
4	230	60	2879	207	0.85	400	507

U = Supply voltage · f = Frequency · n = Speed · Pe = Power input · I = Current draw · LpA<sub>in</sub> = Sound pressure level inlet side · LwA<sub>in</sub> = Sound power level inlet side · qv = Air flow  
 p<sub>e</sub> = Pressure increase

