

R2E225-AY64-11 ebmpapst Datasheet

sales@fansco.com

www.fansco.com

Limited partnership · Headquarters Muldingen  
County court Stuttgart · HRA 590344

General partner Elektrobau Muldingen GmbH · Headquarters Muldingen  
County court Stuttgart · HRB 590142

## Nominal data

Type	R2E225-AY64-11	
Motor	M2E068-DF	
Phase		1~
Nominal voltage	VAC	230
Frequency	Hz	50
Type of data definition		fa
Valid for approval / standard		-
Speed (rpm)	min <sup>-1</sup>	2700
Power input	W	140
Current draw	A	0.62
Motor capacitor	µF	4
Capacitor voltage	VDB	450
Min. back pressure	Pa	0
Min. ambient temperature	°C	-25
Max. ambient temperature	°C	80

ml = Max. load · me = Max. efficiency · fa = Running at free air · cs = Customer specs · cu = Customer unit  
Subject to alterations



### Technical features

<b>Mass</b>	2.7 kg
<b>Size</b>	225 mm
<b>Surface of rotor</b>	Coated in black
<b>Material of impeller</b>	Sheet steel, galvanised
<b>Number of blades</b>	11
<b>Direction of rotation</b>	Clockwise, seen on rotor
<b>Type of protection</b>	IP 44; Depending on installation and position as per EN 60034-5
<b>Insulation class</b>	"F"
<b>Humidity (F)/environmental protection class (H)</b>	F2-2
<b>Max. permissible ambient motor temp. (transp./ storage)</b>	+ 80 °C
<b>Min. permissible ambient motor temp. (transp./storage)</b>	- 40 °C
<b>Mounting position</b>	Shaft horizontal or rotor on bottom; rotor on top on request
<b>Condensate discharge holes</b>	Rotor-side
<b>Operation mode</b>	S1
<b>Motor bearing</b>	Ball bearing
<b>Touch current acc. IEC 60990 (measuring network Fig. 4, TN system)</b>	< 0.75 mA
<b>Motor protection</b>	Thermal overload protector (TOP) brought out, basic insulation
<b>Cable exit</b>	Variable
<b>Protection class</b>	I (if protective earth is connected by customer)
<b>Product conforming to standard</b>	EN 60335-1

Product drawing

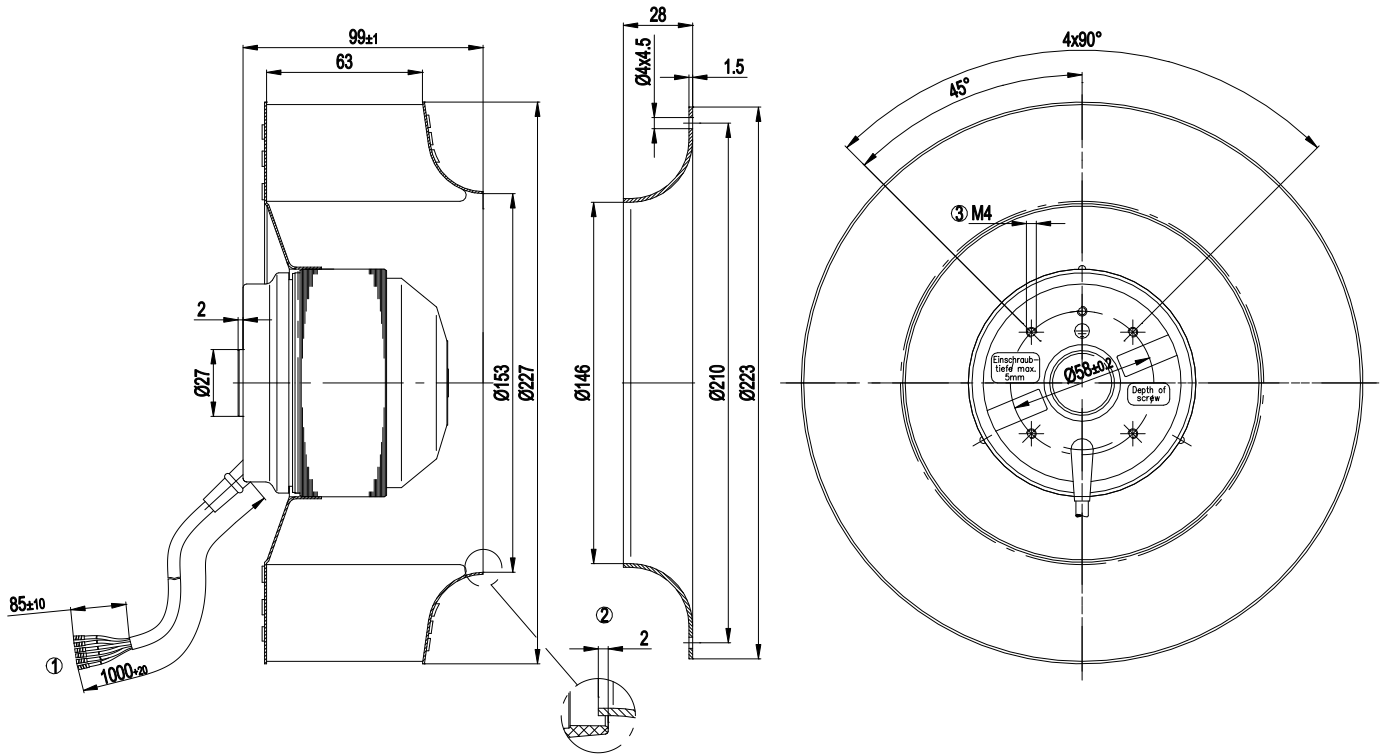

1	Connection line Dipotherm, 6x brass lead tips crimped
2	Accessory part: Inlet nozzle 96358-2-4013, not included in delivery.
3	Depth of screw max. 5 mm

## Connection screen

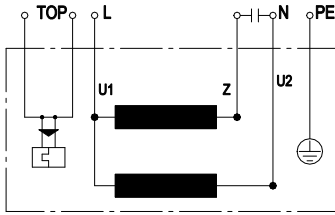

U1	Blue	Z	brown	U2	black
PE	green/yellow	TOP	2 x grey		



## Charts: Air flow 50 Hz

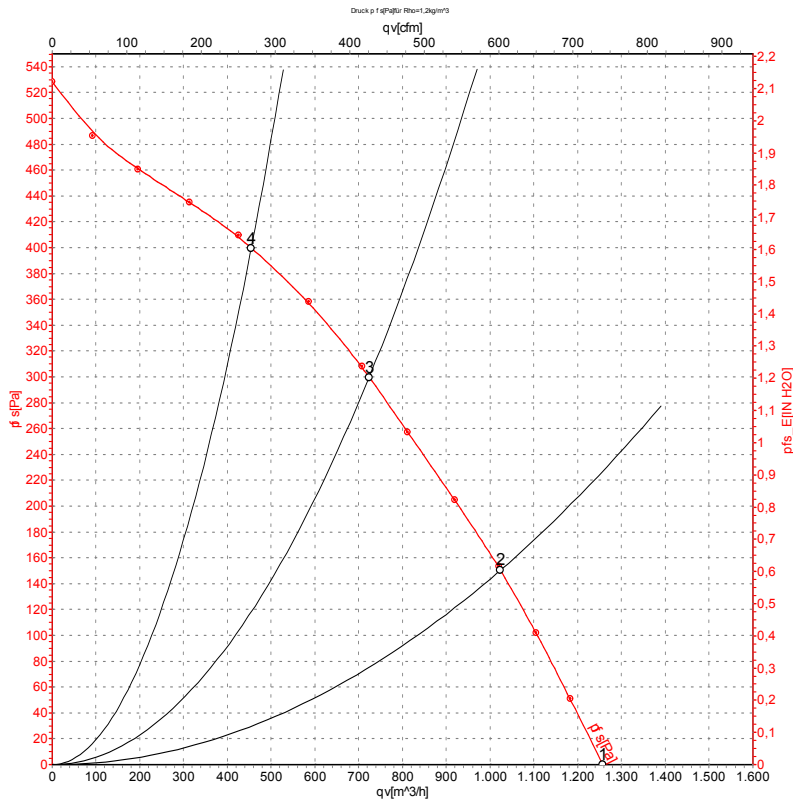

Measurement: LU-27429-1

Air performance measured as per ISO 5801 Installation category A. For detailed information on the measuring set-up, please contact ebmpapst. Suction-side noise levels: L<sub>wA</sub> measured as per ISO 13347 / L<sub>pA</sub> measured with 1m distance to fan axis. The values given are valid under the measuring conditions mentioned above and may vary according to the actual installation situation. With any deviation from the standard set-up, the specific values have to be checked and reviewed with the unit installed.

## Measured values

	U	f	n	P <sub>e</sub>	I	qv	p <sub>fs</sub>	qv	p <sub>fs</sub>
	V	Hz	min <sup>-1</sup>	W	A	m <sup>3</sup> /h	Pa	CFM	inH <sub>2</sub> O
1	230	50	2700	140	0.62	1255	0	740	0.00
2	230	50	2645	156	0.69	1025	150	600	0.60
3	230	50	2590	169	0.74	725	300	425	1.20
4	230	50	2625	162	0.71	455	400	270	1.61

U = Supply voltage · f = Frequency · n = Speed (rpm) · P<sub>e</sub> = Power input · I = Current draw · qv = Air flow · p<sub>fs</sub> = Pressure increase

