

R2E210-AB34-20 ebmpapst Datasheet  
 sales@fansco.com  
 www.fansco.com

Limited partnership · Headquarters Mulfingen  
 County court Stuttgart · HRA 590344

General partner Elektrobau Mulfingen GmbH · Headquarters Mulfingen  
 County court Stuttgart · HRB 590142

## Nominal data

Type	R2E210-AB34-20	
Motor	M2E068-DF	
Phase		1~
Nominal voltage	VAC	230
Frequency	Hz	50
Type of data definition		fa
Valid for approval / standard		CE
Speed (rpm)	min <sup>-1</sup>	2350
Power input	W	120
Current draw	A	0.54
Motor capacitor	µF	2.0
Capacitor voltage	VDB	400
Capacitor standard		S0 (CE)
Min. back pressure	Pa	0
Min. ambient temperature	°C	-25
Max. ambient temperature	°C	60

ml = Max. load · me = Max. efficiency · fa = Running at free air · cs = Customer specs · cu = Customer unit  
 Subject to alterations



### Technical features

Mass	3.89 kg
Size	210 mm
Surface of rotor	Uncoated
Material of impeller	Sheet steel, rust-resistant
Number of blades	6
Direction of rotation	Counter-clockwise, seen on rotor
Type of protection	IP 44; Depending on installation and position
Insulation class	"F"
Humidity (F)/environmental protection class (H)	F1-1
Max. permissible ambient motor temp. (transp./ storage)	+ 80 °C
Min. permissible ambient motor temp. (transp./storage)	- 40 °C
Mounting position	Any
Condensate discharge holes	None
Operation mode	S1
Motor bearing	Ball bearing
Touch current acc. IEC 60990 (measuring network Fig. 4, TN system)	< 0.75 mA
Electrical leads	With plug
Motor protection	Thermal overload protector (TOP) wired internally
Cable exit	Variable
Protection class	I (if protective earth is connected by customer)
Motor capacitor according to EN 60252-1 in safety protection class	S2
Product conforming to standard	EN 60335-1; CE

## Product drawing

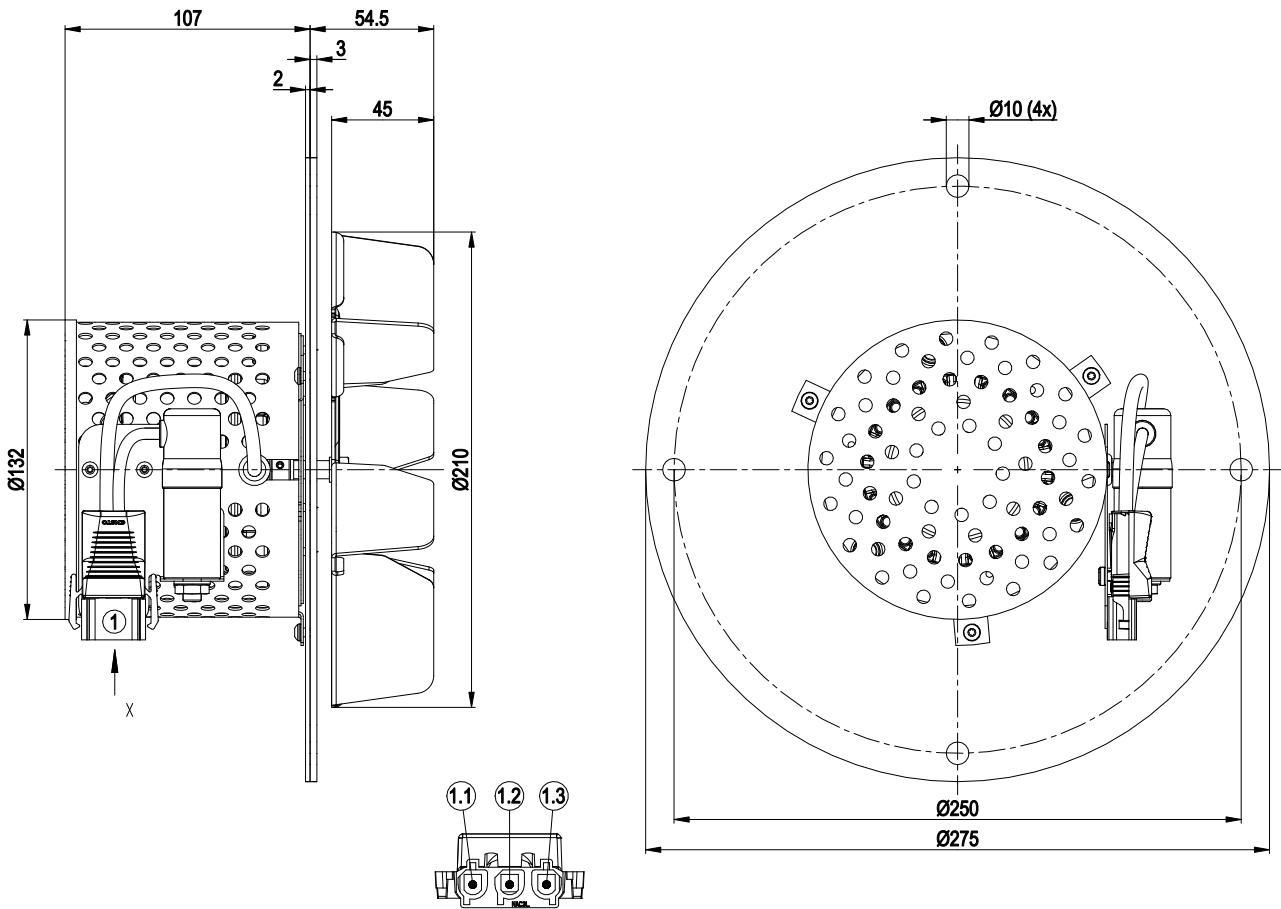

1	Connector housing 3-pole ENSTO NAC31S.W
1.1	blue
1.2	green/yellow
1.3	black + capacitor

## Connection screen

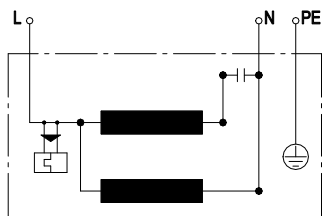

L	blue	N	black	PE	green/yellow
---	------	---	-------	----	--------------



## Charts: Air flow 50 Hz

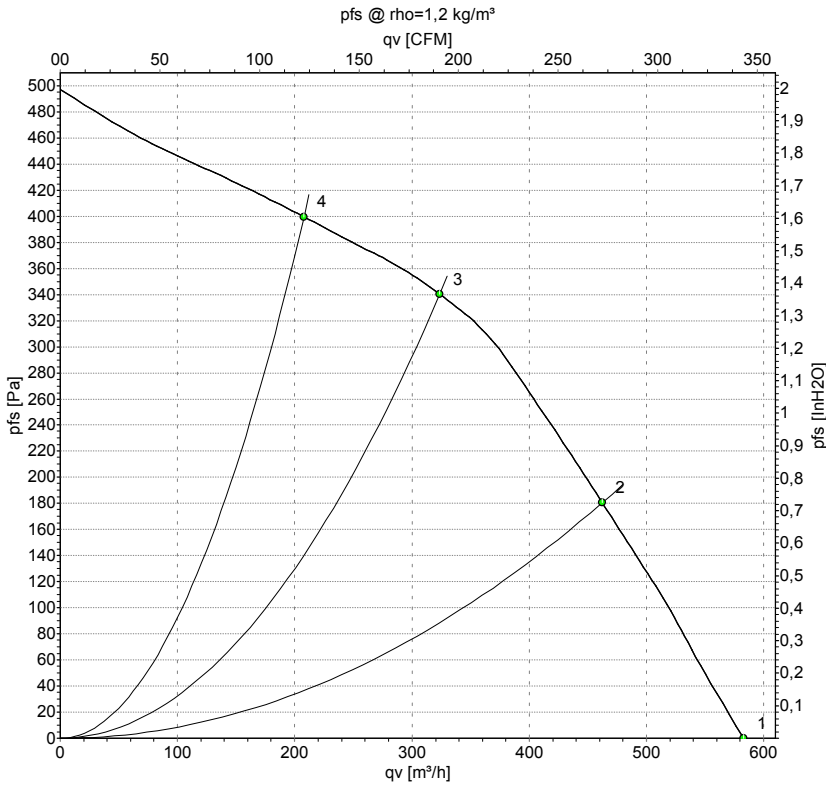

Measurement: LU-138693-1

Air performance measured as per ISO 5801 Installation category A. For detailed information on the measuring set-up, please contact ebm-papst. Suction-side noise levels: LwA measured as per ISO 13347 / LpA measured with 1m distance to fan axis. The values given are valid under the measuring conditions mentioned above and may vary according to the actual installation situation. With any deviation from the standard set-up, the specific values have to be checked and reviewed with the unit installed.

## Measured values

	U	f	n	P <sub>e</sub>	I	q <sub>v</sub>	p <sub>fs</sub>	q <sub>v</sub>	p <sub>fs</sub>
	V	Hz	min <sup>-1</sup>	W	A	m³/h	Pa	cfm	inH2O
1	230	50	2350	120	0.54	585	0	345	0.00
2	230	50	2380	119	0.52	460	180	270	0.72
3	230	50	2520	103	0.45	325	340	190	1.36
4	230	50	2610	93	0.40	210	400	120	1.61

U = Supply voltage · f = Frequency · n = Speed (rpm) · P<sub>e</sub> = Power input · I = Current draw · q<sub>v</sub> = Air flow · p<sub>fs</sub> = Pressure increase

