

R2E210-AA34-14 ebmpapst Datasheet FansCo

sales@fansco.com

www.fansco.com

Nominal data

Type	R2E210-AA34-14	
Motor	M2E068-DF	
Phase		1~
Nominal voltage	VAC	230
Frequency	Hz	50
Method of obtaining data		fa
Valid for approval/standard		CE
Speed (rpm)	min ⁻¹	2550
Power consumption	W	100
Current draw	A	0.45
Capacitor	μF	2
Capacitor voltage	VDB	450
Capacitor standard		S0 (CE)
Min. back pressure	Pa	0
Min. back pressure	in. wg	0
Min. ambient temperature	°C	-25
Max. ambient temperature	°C	60
Starting current	A	0.85

ml = Max. load · me = Max. efficiency · fa = Free air · cs = Customer specification · ce = Customer equipment
 Subject to change



Technical description

Weight	2.9 kg
Size	210 mm
Motor size	68
Impeller material	Sheet steel, stainless
Support plate material	Sheet steel, hot-dip galvanized
Number of blades	6
Motor suspension	Motor mounted on support plate for one-sided vibration damping
Direction of rotation	Counterclockwise, viewed toward rotor
Degree of protection	IP44; installation- and position-dependent
Insulation class	"F"
Moisture (F) / Environmental (H) protection class	H0 - dry environment
Max. permitted ambient temp. for motor (transport/storage)	+ 80 °C
Min. permitted ambient temp. for motor (transport/storage)	- 40 °C
Installation position	Any
Condensation drainage holes	None
Mode	S1
Motor mounting	Ball bearing
Touch current according to IEC 60990 (measuring circuit Fig. 4, TN system)	< 0.75 mA
Motor protection	Thermal overload protector (TOP) internally connected
With cable	Variable
Protection class	I (with customer connection of protective earth)
Motor capacitor according to EN 60252-1 in safety protection class	S2
Conformity with standards	EN 60034-1; EN 60204-1; CE

Product drawing

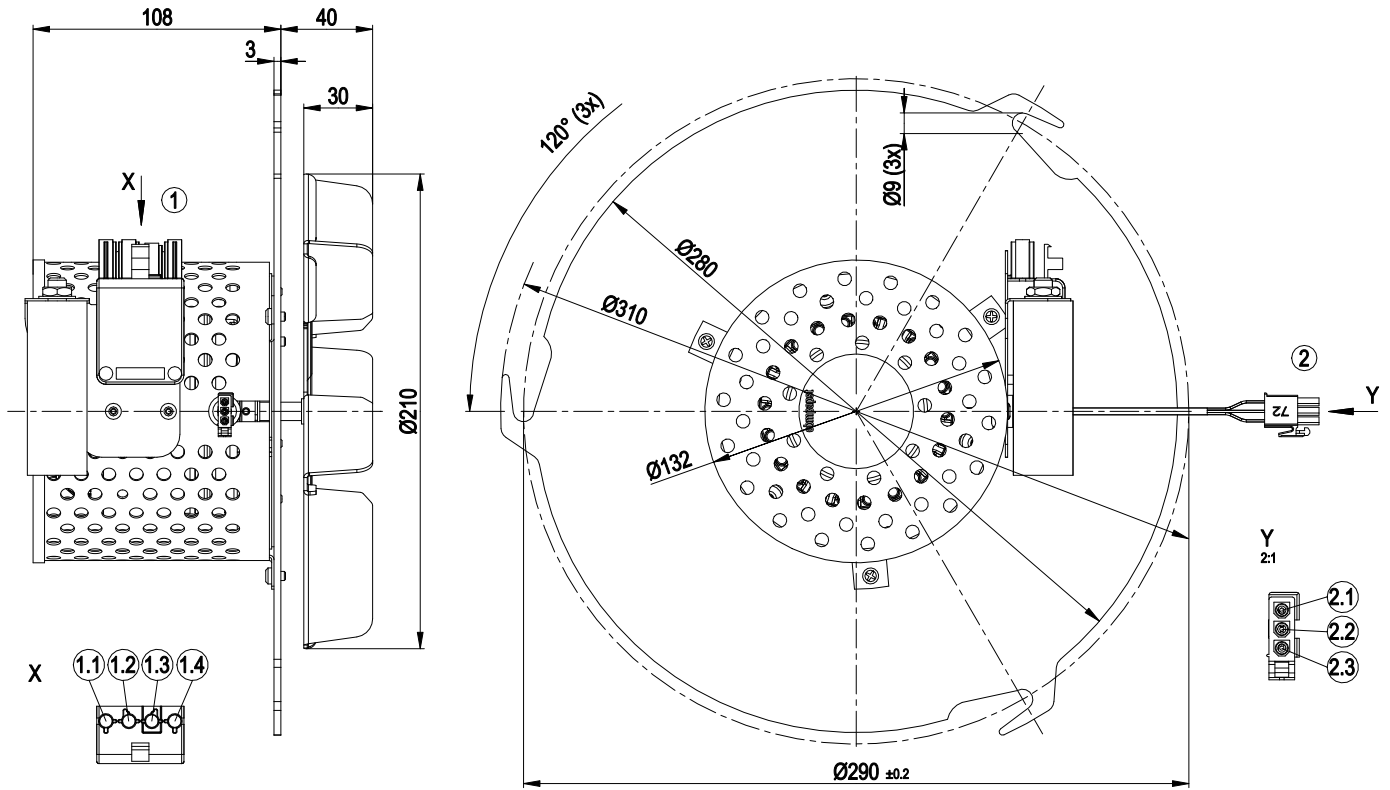

1	4-pole connector housing Wieland 93.932.4857.0
1.1	free
1.2	L = blue
1.3	PE = green/yellow
1.4	N = black
2	Cable Raychem Spec. 44, AWG24, 3-pole connector housing tyco 172166-1, 3x socket contact tyco 170361-1
2.1	black
2.2	white
2.3	red



Connection diagram

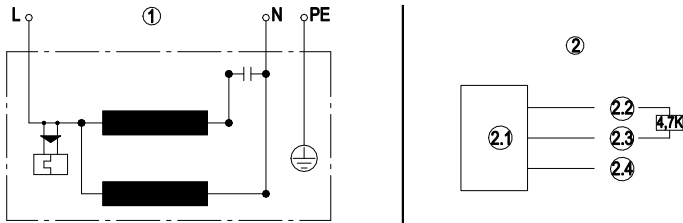

1 Fan connection diagram

L blue

N black

PE green/yellow

2 Hall IC circuit

2.1 Hall IC

2.2 red (+5 V)

2.3 white (out)

2.4 black (0 V)

Curves: Air performance 50 Hz

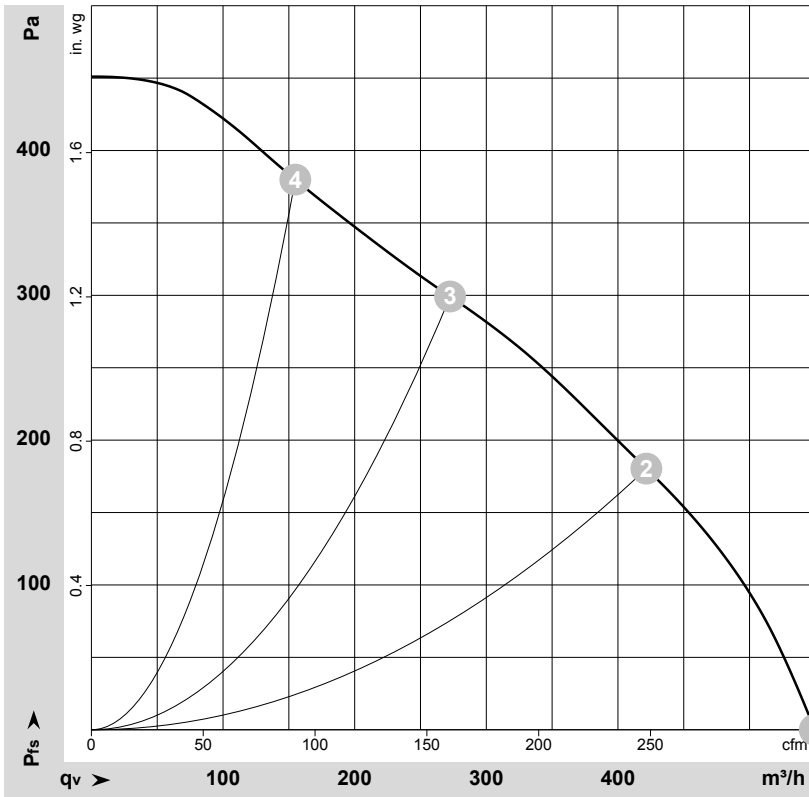

$\rho = 1.15 \text{ kg/m}^3 \pm 2 \%$

Measurement: LU-78617-1

Air performance measured according to ISO 5801 installation category A. For detailed information on the measurement setup, contact ebmpapst. Intake sound level: Sound power level according to ISO 13347 / sound pressure level measured at 1 m distance from fan axis. The values given are valid under the specified measuring conditions and may vary due to conditions of installation. For deviations from the standard configuration, the parameters have to be checked on the installed unit.

Measured values

	Wired	U	f	n	P _e	I	q _v	p _{fs}	q _v	p _{fs}
		V	Hz	min ⁻¹	W	A	m ³ /h	Pa	cfm	in. wg
1	1~	230	50	2550	100	0.45	550	0	325	0.00
2	1~	230	50	2535	100	0.44	420	180	250	0.72
3	1~	230	50	2625	88	0.38	270	300	160	1.20
4	1~	230	50	2710	77	0.33	155	380	90	1.53

Wired = Wiring · U = Power supply · f = Frequency · n = Speed (rpm) · P_e = Power consumption · I = Current draw · q_v = Air flow · p_{fs} = Pressure increase

