

R2E210-AA34-01 ebmpapst Datasheet

sales@fansco.com

www.fansco.com

Nominal data

Type	R2E210-AA34-01	
Motor	M2E068-DF	
Phase		1~
Nominal voltage	VAC	230
Frequency	Hz	50
Method of obtaining data		fa
Valid for approval/standard		CE
Speed (rpm)	min ⁻¹	2500
Power consumption	W	110
Current draw	A	0.49
Capacitor	μF	2
Capacitor voltage	VDB	450
Capacitor standard		S0 (CE)
Min. back pressure	Pa	0
Min. back pressure	in. wg	0
Min. ambient temperature	°C	-25
Max. ambient temperature	°C	90

ml = Max. load · me = Max. efficiency · fa = Free air · cs = Customer specification · ce = Customer equipment
Subject to change



Technical description

Weight	3 kg
Size	210 mm
Motor size	68
Impeller material	Sheet steel, stainless
Support plate material	Sheet steel, hot-dip galvanized
Number of blades	6
Motor suspension	Motor mounted on support plate for one-sided vibration damping
Direction of rotation	Counterclockwise, viewed toward rotor
Degree of protection	IP44; installation- and position-dependent
Insulation class	"F"
Moisture (F) / Environmental (H) protection class	H0 - dry environment
Max. permitted ambient temp. for motor (transport/storage)	+ 80 °C
Min. permitted ambient temp. for motor (transport/storage)	- 40 °C
Installation position	Any
Condensation drainage holes	None
Mode	S1
Motor bearing	Ball bearing
Touch current according to IEC 60990 (measuring circuit Fig. 4, TN system)	< 0.75 mA
Motor protection	Thermal overload protector (TOP) internally connected
With cable	Variable
Protection class	I (with customer connection of protective earth)
Conformity with standards	EN 60335-1; CE
Approval	EAC

Product drawing

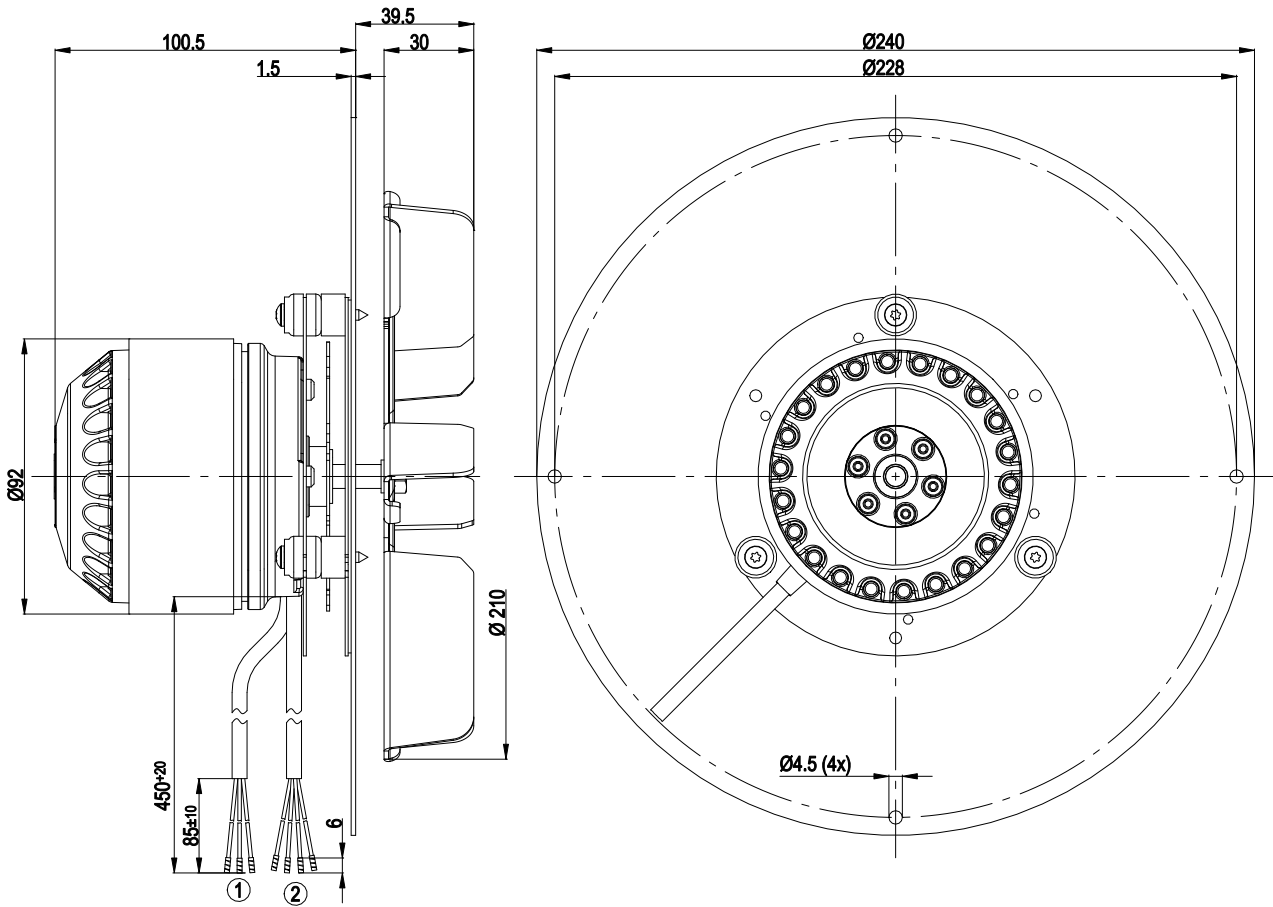

- | | |
|---|---|
| 1 | Cable Raychem AWG24, 3x crimped splices. |
| 2 | Cable silicone 4G 0.5 mm ² , 4x crimped splices. |

Connection diagram

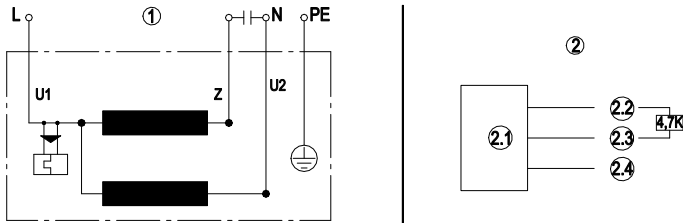

1 Fan connection diagram

U1 blue

Z brown

U2 black

PE green/yellow

2 Hall IC circuit

2.1 Hall IC

2.2 red (+5 V)

2.3 white (out)

2.4 black (0 V)

Curves: Air performance 50 Hz

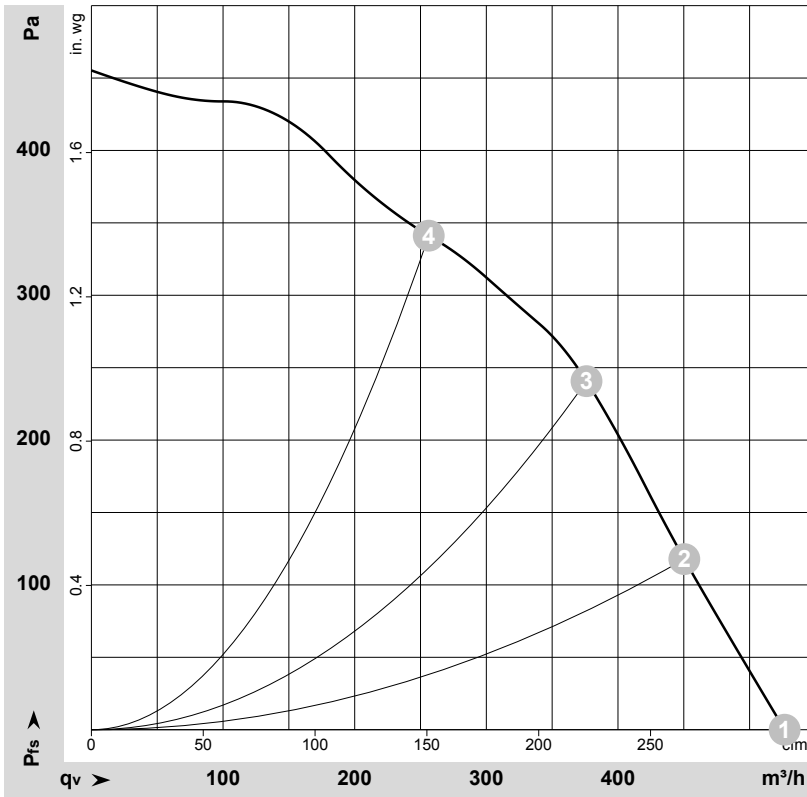

$\rho = 1.15 \text{ kg/m}^3 \pm 2 \%$

Measurement: LU-148468-1

Air performance measured according to ISO 5801 installation category A. For detailed information on the measurement setup, contact ebmpapst. Intake sound level: Sound power level according to ISO 13347 / sound pressure level measured at 1 m distance from fan axis. The values given are valid under the specified measuring conditions and may vary due to conditions of installation. For deviations from the standard configuration, the parameters have to be checked on the installed unit.

Measured values

	Wired	U	f	n	P _e	I	q _v	P _{fs}	q _v	P _{fs}
		V	Hz	min ⁻¹	W	A	m ³ /h	Pa	cfm	in. wg
1	1~	230	50	2500	110	0.49	525	0	310	0.00
2	1~	230	50	2495	109	0.48	450	120	265	0.48
3	1~	230	50	2555	101	0.44	375	240	220	0.96
4	1~	230	50	2670	86	0.37	255	340	150	1.36

Wired = Wiring · U = Voltage · f = Frequency · n = Speed (rpm) · P_e = Power consumption · I = Current draw · q_v = Air flow · P_{fs} = Pressure increase

