

R2E190-AO26-85 ebmpapst Datasheet

sales@fansco.com

www.fansco.com

Limited partnership · Headquarters Mulfingen

Amtsgericht (court of registration) Stuttgart · HRA 590344

General partner Elektrobau Mulfingen GmbH · Headquarters Mulfingen

Amtsgericht (court of registration) Stuttgart · HRB 590142

Nominal data

Type	R2E190-AO26-85			
Motor	M2E068-BF			
Phase		1~	1~	1~
Nominal voltage	VAC	230	230	230
Frequency	Hz	50	60	60
Method of obtaining data		fa	fa	fa
Valid for approval/standard		CE	CE	UL 2111
Speed (rpm)	min ⁻¹	2500	2700	2700
Power consumption	W	58	75	80
Current draw	A	0.26	0.34	0.35
Capacitor	µF	2	2	2
Capacitor voltage	VDB	400	400	400
Min. back pressure	Pa	0	0	0
Min. back pressure	inH ₂ O	0	0	0
Min. ambient temperature	°C	-25	-25	-25
Max. ambient temperature	°C	50	55	55
Starting current	A	0.40	0.41	

ml = Max. load · me = Max. efficiency · fa = Free air · cs = Customer specification · ce = Customer equipment
Subject to change



Technical description

Weight	1.3 kg
Fan size	190 mm
Rotor surface	Painted black
Impeller material	PA plastic
Direction of rotation	Clockwise, viewed toward rotor
Degree of protection	IP44; installation- and position-dependent as per EN 60034-5
Insulation class	"B"
Moisture (F) / Environmental (H) protection class	H0+
Max. permitted ambient temp. for motor (transport/storage)	+ 80 °C
Min. permitted ambient temp. for motor (transport/storage)	- 40 °C
Installation position	Shaft horizontal or rotor on bottom; rotor on top on request
Condensation drainage holes	On rotor side
Mode	S1
Motor bearing	Ball bearing
Touch current according to IEC 60990 (measuring circuit Fig. 4, TN system)	< 0.75 mA
Motor protection	Thermal overload protector (TOP) internally connected
With cable	Variable
Protection class	I (with customer connection of protective earth)
Motor capacitor according to EN 60252-1 in safety protection class	S0
Conformity with standards	EN 60335-1; CE
Approval	CCC; CSA C22.2 No. 77; UL 1004-3

Product drawing

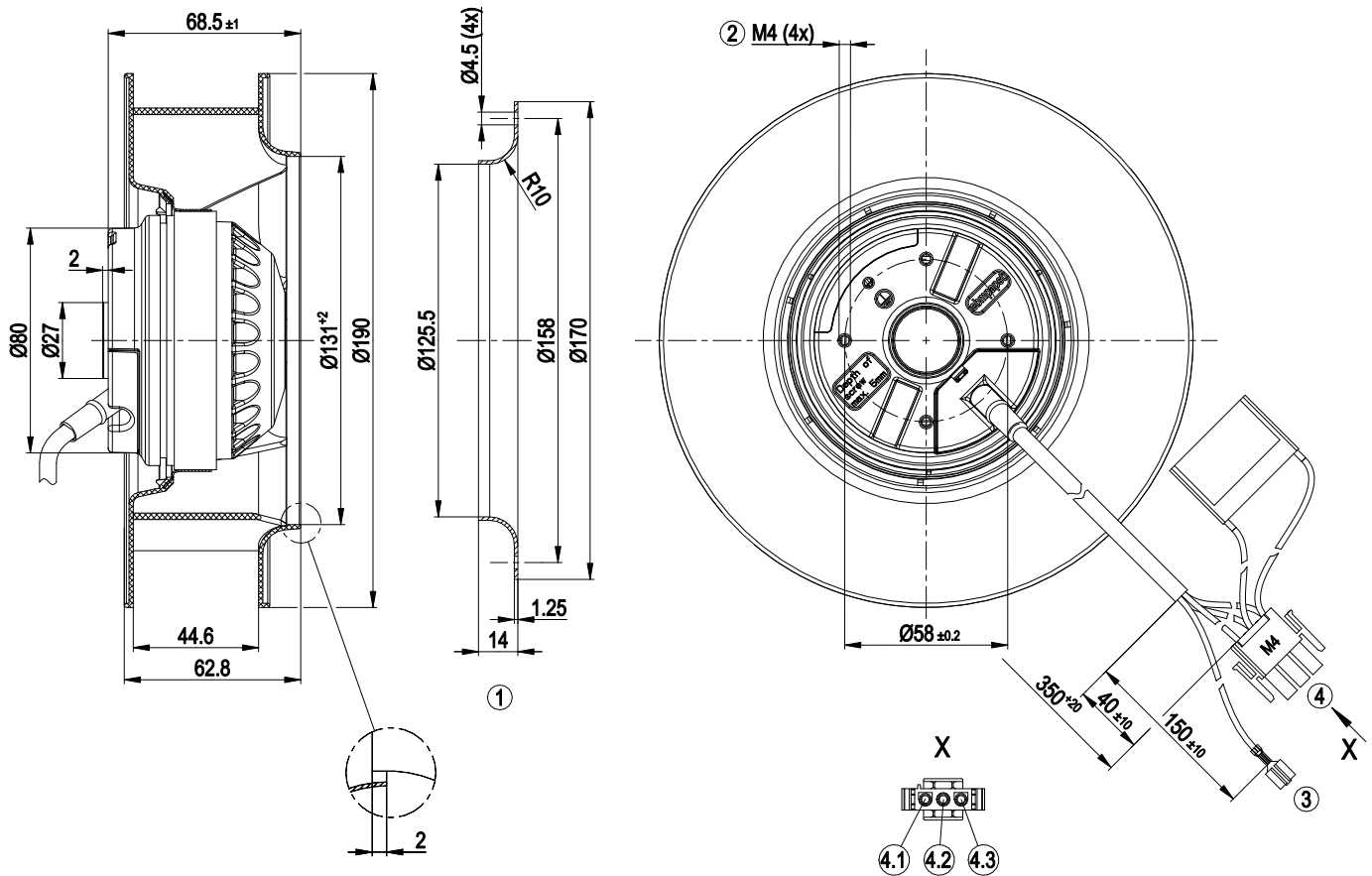

1	Accessory part: Inlet ring 09576-2-4013, not included in scope of delivery
2	Max. clearance for screw 5 mm
3	PE (green-yellow), flat push-on receptacle 6.3x0.8, lockable
4	Cable PVC AWG20, 3-pole connector housing Tyco 350766-4, 2x plug pin Tyco 350538-1 and 1x plug pin Tyco 926885-1
4.1	L (blue)
4.2	Z (brown + capacitor)
4.3	N (black + capacitor)



Connection diagram

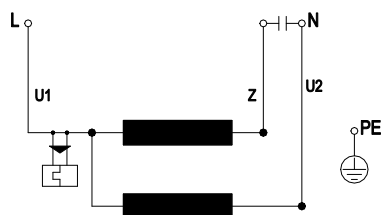

U1	blue	Z	brown	U2	black
PE	green/yellow				

Curves: Air performance 50 Hz

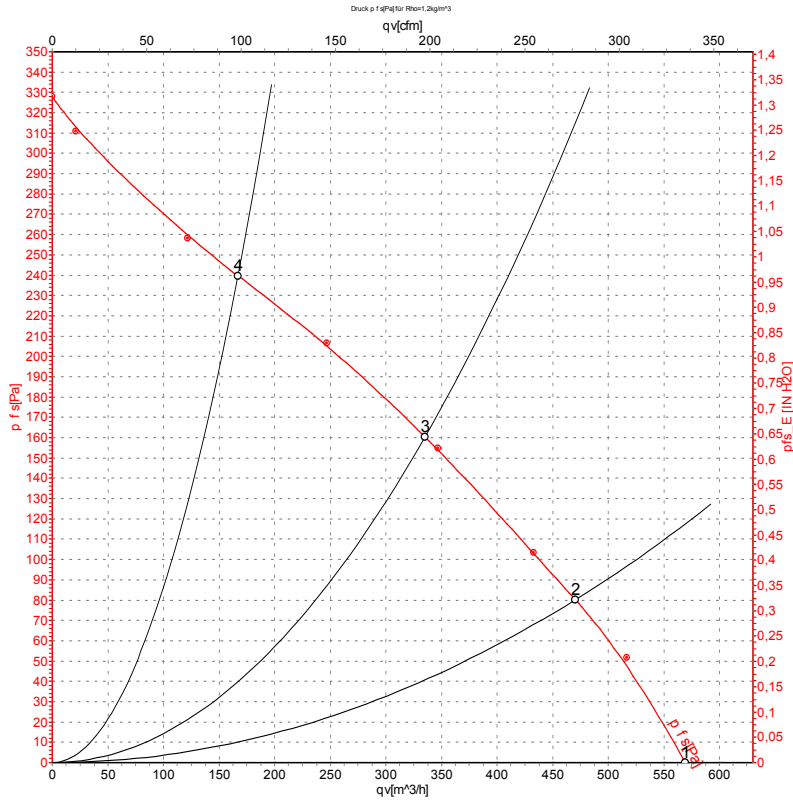

Measurement: LU-53162-1

Air performance measured according to ISO 5801 installation category A. For detailed information on the measurement setup, contact ebmpapst. Intake sound level: Sound power level according to ISO 13347 / sound pressure level measured at 1 m distance from fan axis. The values given are valid under the specified measuring conditions and may vary due to conditions of installation. For deviations from the standard configuration, the parameters have to be checked on the installed unit.

Measured values

	U	f	n	P _e	I	q _v	P _{fs}	q _v	P _{fs}
	V	Hz	min ⁻¹	W	A	m ³ /h	Pa	cfm	inH ₂ O
1	230	50	2500	58	0.26	570	0	335	0.00
2	230	50	2470	60	0.26	470	80	275	0.32
3	230	50	2415	61	0.27	335	160	195	0.64
4	230	50	2500	58	0.25	165	240	100	0.96

U = Power supply · f = Frequency · n = Speed (rpm) · P_e = Power consumption · I = Current draw · q_v = Air flow · P_{fs} = Pressure increase



Curves: Air performance 60 Hz

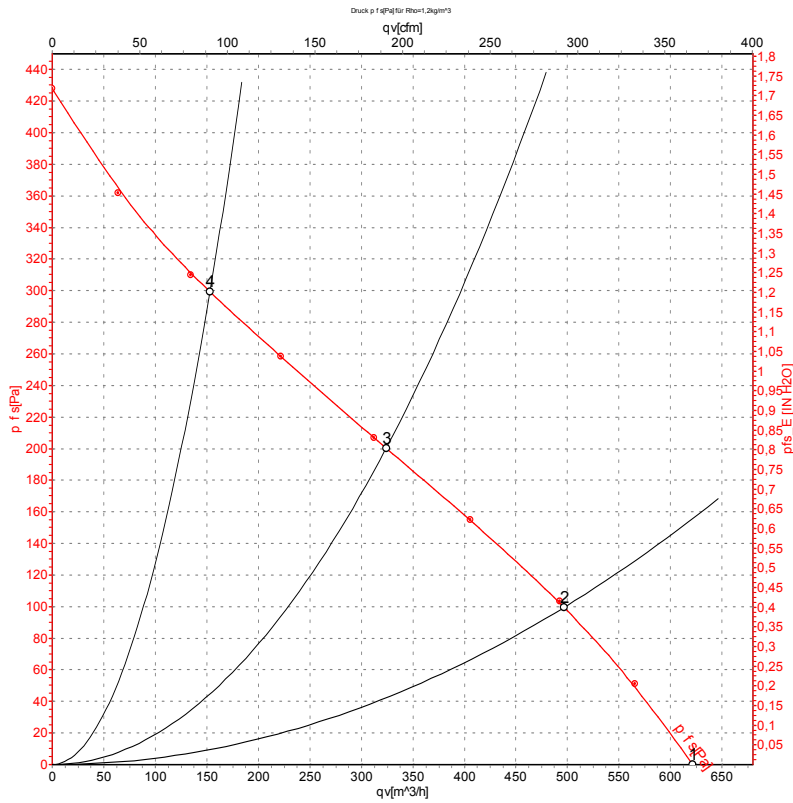

Measurement: LU-53163-1

Air performance measured according to ISO 5801 installation category A. For detailed information on the measurement setup, contact ebmpapst. Intake sound level: Sound power level according to ISO 13347 / sound pressure level measured at 1 m distance from fan axis. The values given are valid under the specified measuring conditions and may vary due to conditions of installation. For deviations from the standard configuration, the parameters have to be checked on the installed unit.

Measured values

	U	f	n	P _e	I	q _v	P _{fs}	q _v	P _{fs}
	V	Hz	min ⁻¹	W	A	m ³ /h	Pa	cfm	inH ₂ O
1	230	60	2700	75	0.34	620	0	365	0.00
2	230	60	2690	76	0.34	495	100	295	0.40
3	230	60	2570	79	0.35	325	200	190	0.80
4	230	60	2755	75	0.33	155	300	90	1.20

U = Power supply · f = Frequency · n = Speed (rpm) · P_e = Power consumption · I = Current draw · q_v = Air flow · P_{fs} = Pressure increase

