

for solid fuel heating systems

R2E180-CG82-38 ebmpapst Datasheet

sales@fansco.com

www.fansco.com

Limited partnership · Headquarters Muldingen
County court Stuttgart · HRA 590344

General partner Elektrobau Muldingen GmbH · Headquarters Muldingen
County court Stuttgart · HRB 590142

Nominal data

Type	R2E180-CG82-38	
Motor	M2E068-CF	
Phase		1~
Nominal voltage	VAC	230
Frequency	Hz	50
Type of data definition		fa
Valid for approval / standard		CE
Speed (rpm)	min ⁻¹	2530
Power input	W	68
Current draw	A	0.30
Motor capacitor	µF	2
Capacitor voltage	VDB	400
Capacitor standard		S0 (CE)
Min. back pressure	Pa	0
Min. ambient temperature	°C	-25
Max. ambient temperature	°C	60

ml = Max. load · me = Max. efficiency · fa = Running at free air · cs = Customer specs · cu = Customer unit
Subject to alterations



Technical features

Mass	2.6 kg
Size	180 mm
Surface of rotor	Uncoated
Material of impeller	Aluminium sheet
Number of blades	6
Motor suspension	Motor anti-vibration mounted on one side via mounting plate
Direction of rotation	Counter-clockwise, seen on rotor
Type of protection	IP 44; Depending on installation and position
Insulation class	"F"
Humidity (F)/environmental protection class (H)	H0 - dry environment
Max. permissible ambient motor temp. (transp./ storage)	+ 80 °C
Min. permissible ambient motor temp. (transp./storage)	- 40 °C
Mounting position	Any
Condensate discharge holes	None
Operation mode	S1
Motor bearing	Ball bearing
Touch current acc. IEC 60990 (measuring network Fig. 4, TN system)	< 0.75 mA
Motor protection	Thermal overload protector (TOP) wired internally
Cable exit	Variable
Protection class	I (if protective earth is connected by customer)
Motor capacitor according to EN 60252-1 in safety protection class	S2
Product conforming to standard	EN 60335-1; CE

Product drawing

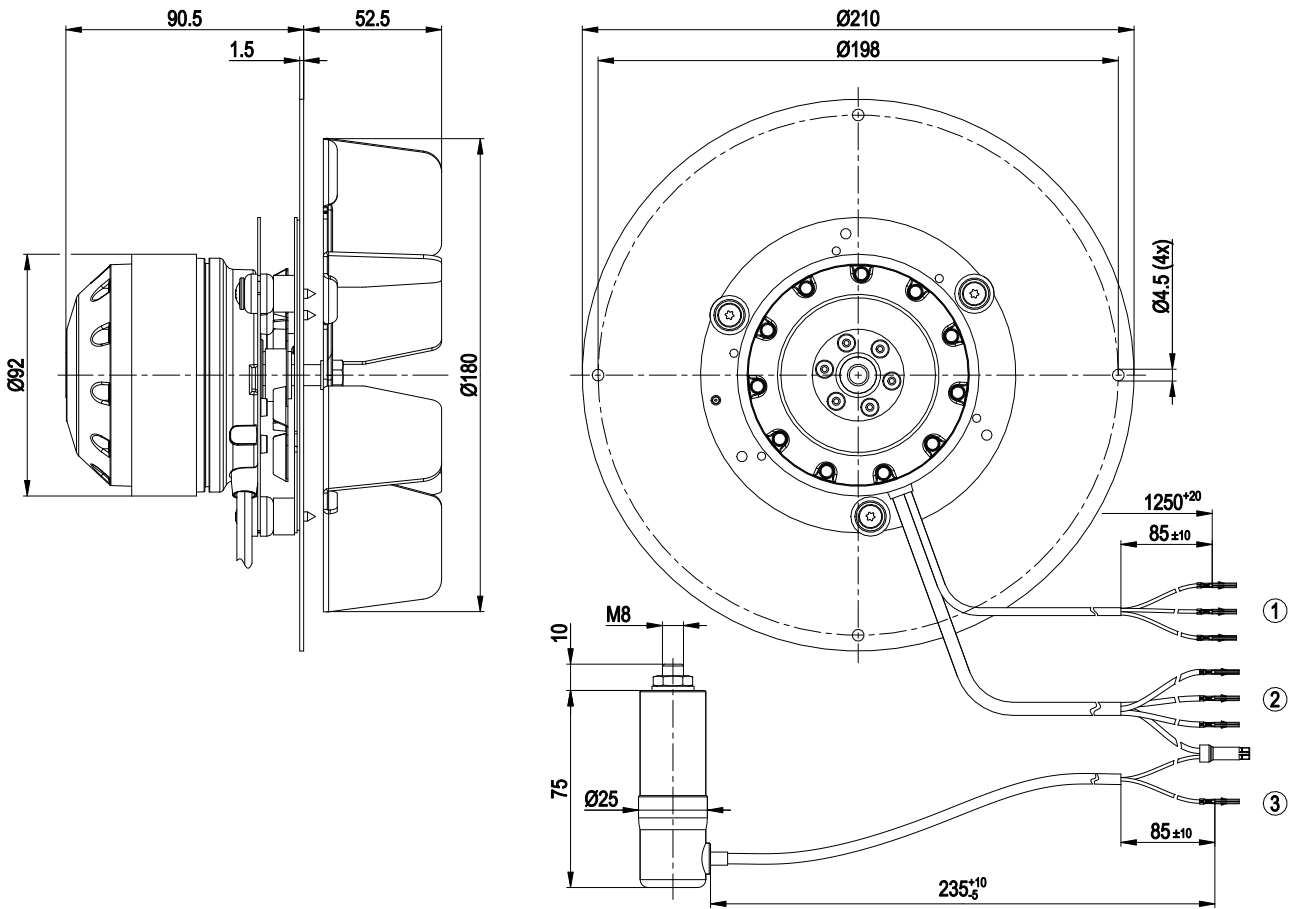

- | | |
|---|--|
| 1 | Connection line Raychem Spec. 44, AWG24, 3x female connector Molex 39-00-0065 crimped |
| 2 | Connection line silicone 4G 0.5 mm ² , 3x female connector Molex 39-00-0059 crimped |
| 3 | Capacitor, 1x female connector Molex 39-00-0059 crimped |



Connection screen

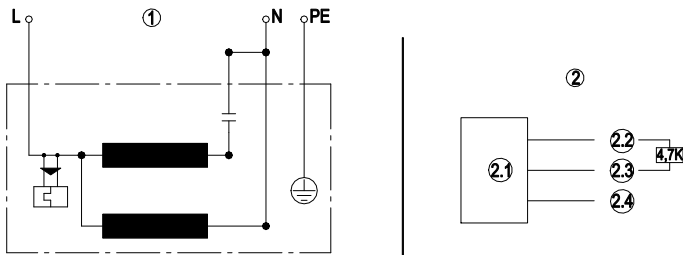

1	Fan connection diagram
---	------------------------

L	blue
---	------

N	black
---	-------

PE	green/yellow
----	--------------

2	Hall IC circuit
---	-----------------

2.1	Hall IC
-----	---------

2.2	red (+5 V)
-----	------------

2.3	white (out)
-----	-------------

2.4	black (0 V)
-----	-------------

Charts: Air flow 50 Hz

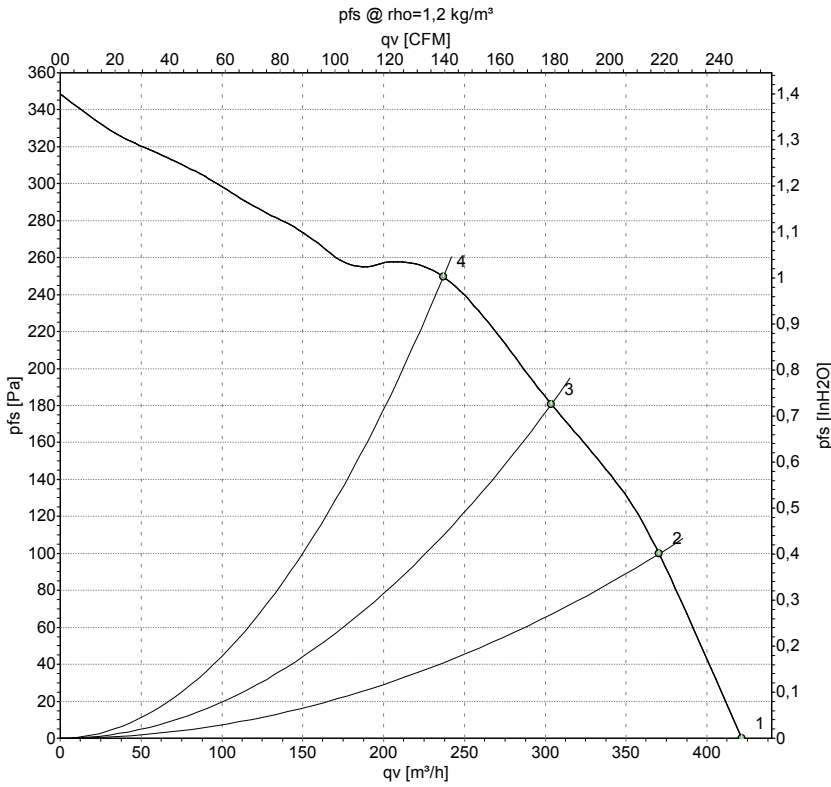

Measurement: LU-144749-1

Air performance measured as per ISO 5801 Installation category A. For detailed information on the measuring set-up, please contact ebm-papst. Suction-side noise levels: LwA measured as per ISO 13347 / LpA measured with 1m distance to fan axis. The values given are valid under the measuring conditions mentioned above and may vary according to the actual installation situation. With any deviation from the standard set-up, the specific values have to be checked and reviewed with the unit installed.

Measured values

	U	f	n	P _e	I	q _v	p _{fs}	q _v	p _{fs}
	V	Hz	min ⁻¹	W	A	m³/h	Pa	cfm	inH2O
1	230	50	2530	68	0.30	420	0	250	0.00
2	230	50	2520	68	0.30	370	100	220	0.40
3	230	50	2540	66	0.29	305	180	180	0.72
4	230	50	2590	62	0.27	235	250	140	1.00

U = Supply voltage · f = Frequency · n = Speed (rpm) · P_e = Power input · I = Current draw · q_v = Air flow · p_{fs} = Pressure increase