

R2E180-CD62-09 ebmpapst Datasheet

sales@fansco.com

www.fansco.com

Limited partnership · Headquarters Muldingen

Amtsgericht (court of registration) Stuttgart · HRA 590344

General partner Elektrobau Muldingen GmbH · Headquarters Muldingen

Amtsgericht (court of registration) Stuttgart · HRB 590142

Nominal data

| Type | R2E180-CD62-09 | | |
|-----------------------------|-------------------|---------|---------|
| Motor | M2E052-BF | | |
| Phase | | 1~ | 1~ |
| Nominal voltage | VAC | 230 | 230 |
| Frequency | Hz | 50 | 60 |
| Method of obtaining data | | fa | fa |
| Valid for approval/standard | | CE | CE |
| Speed (rpm) | min ⁻¹ | 1920 | 1820 |
| Power consumption | W | 40 | 47 |
| Current draw | A | 0.18 | 0.21 |
| Capacitor | µF | 1.5 | 1.5 |
| Capacitor voltage | VDB | 400 | 400 |
| Capacitor standard | | S0 (CE) | S0 (CE) |
| Min. back pressure | Pa | 0 | 0 |
| Min. back pressure | inH2O | 0 | 0 |
| Max. ambient temperature | °C | 75 | 60 |
| Starting current | A | 0.2 | 0.22 |

ml = Max. load · me = Max. efficiency · fa = Free air · cs = Customer specification · ce = Customer equipment
Subject to change



Technical description

| | |
|--|---|
| Weight | 0.9 kg |
| Fan size | 180 mm |
| Rotor surface | Painted black |
| Impeller material | Sheet steel, stainless |
| Support bracket material | Die-cast aluminum |
| Number of blades | 7 |
| Direction of rotation | Clockwise, viewed toward rotor |
| Insulation class | "F" |
| Max. permitted ambient temp. for motor (transport/storage) | + 80 °C |
| Min. permitted ambient temp. for motor (transport/storage) | - 40 °C |
| Installation position | Any |
| Condensation drainage holes | On rotor side |
| Mode | S1 |
| Motor bearing | Ball bearing |
| Touch current according to IEC 60990 (measuring circuit Fig. 4, TN system) | < 0.75 mA |
| Motor protection | Thermal overload protector (TOP) internally connected |
| Protection class | I (with customer connection of protective earth) |
| Conformity with standards | EN 60335-1; CE |

Product drawing

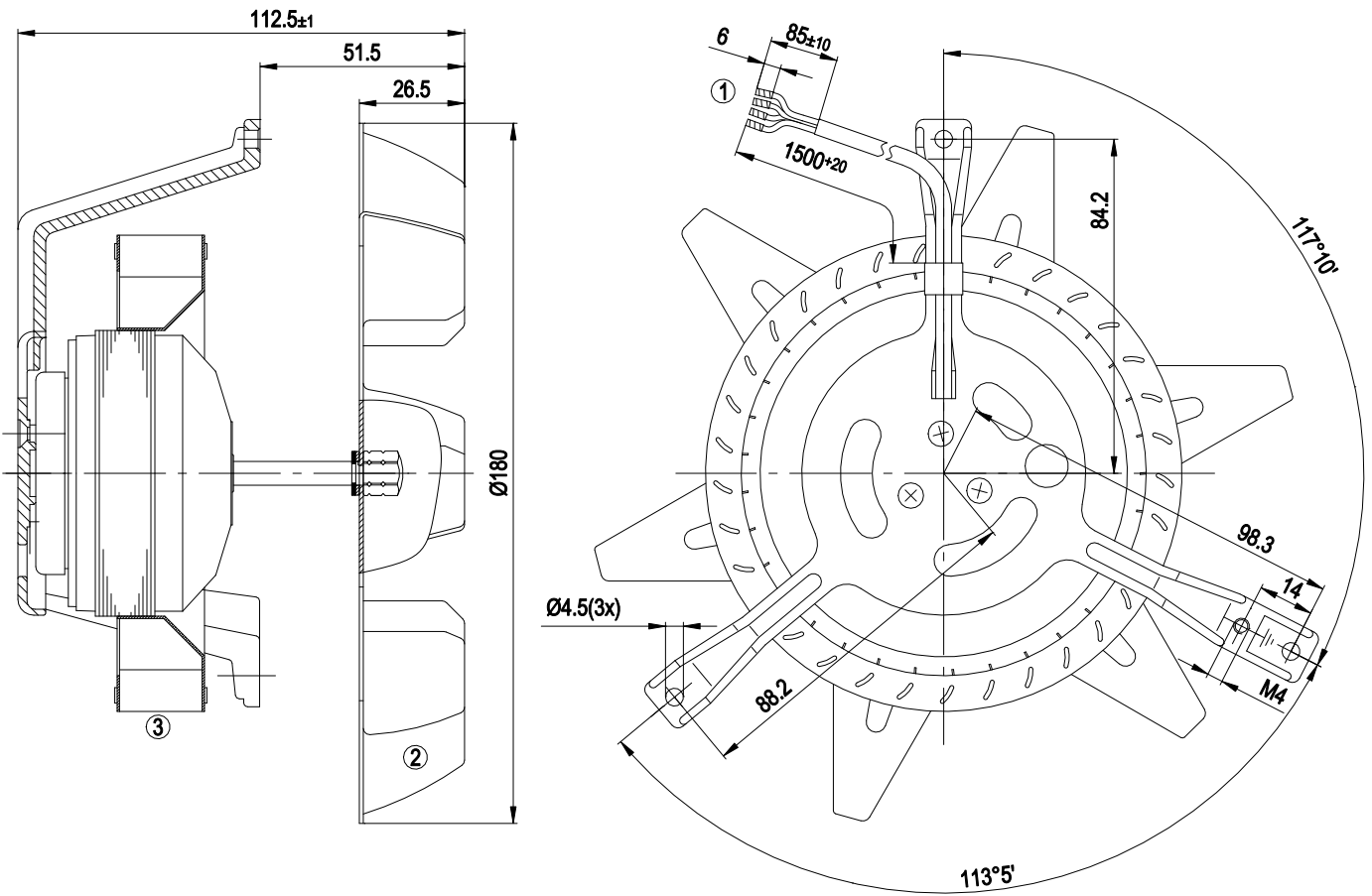

- | | |
|---|--|
| 1 | Cable Dipotherm 0.5 mm ² , 4x crimped splices |
| 2 | Centrifugal fan impeller (stainless steel) |
| 3 | Fan impeller (sheet steel, hot-dip galvanized) |

Connection diagram



| | | | | | |
|----|--------------|---|-------|----|-------|
| U1 | blue | Z | brown | U2 | black |
| PE | green/yellow | | | | |

Curves: Air performance 50 Hz

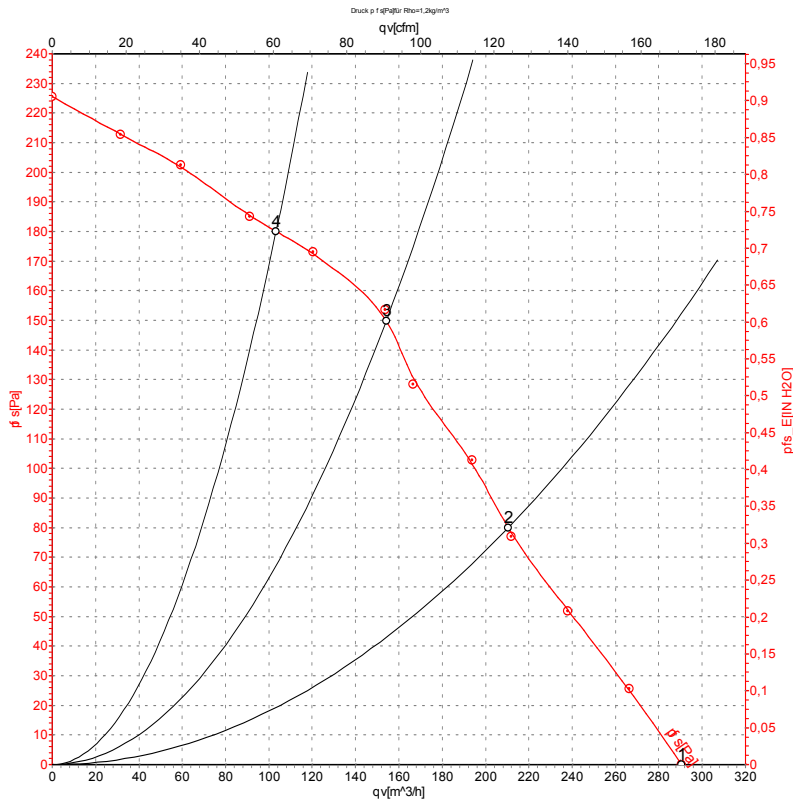

Measurement: LU-61437-1

Air performance measured according to ISO 5801 installation category A. For detailed information on the measurement setup, contact ebm-papst. Intake sound level: Sound power level according to ISO 13347 / sound pressure level measured at 1 m distance from fan axis. The values given are valid under the specified measuring conditions and may vary due to conditions of installation. For deviations from the standard configuration, the parameters have to be checked on the installed unit.

Measured values

| | U | f | n | P _e | I | q _v | P _{fs} | q _v | P _{fs} |
|---|-----|----|-------------------|----------------|------|-------------------|-----------------|----------------|--------------------|
| | V | Hz | min ⁻¹ | W | A | m ³ /h | Pa | cfm | inH ₂ O |
| 1 | 230 | 50 | 1920 | 40 | 0.18 | 290 | 0 | 170 | 0.00 |
| 2 | 230 | 50 | 1915 | 41 | 0.18 | 210 | 80 | 125 | 0.32 |
| 3 | 230 | 50 | 2095 | 39 | 0.18 | 155 | 150 | 90 | 0.60 |
| 4 | 230 | 50 | 2215 | 38 | 0.17 | 105 | 180 | 60 | 0.72 |

U = Power supply · f = Frequency · n = Speed (rpm) · P_e = Power consumption · I = Current draw · q_v = Air flow · P_{fs} = Pressure increase



Curves: Air performance 60 Hz

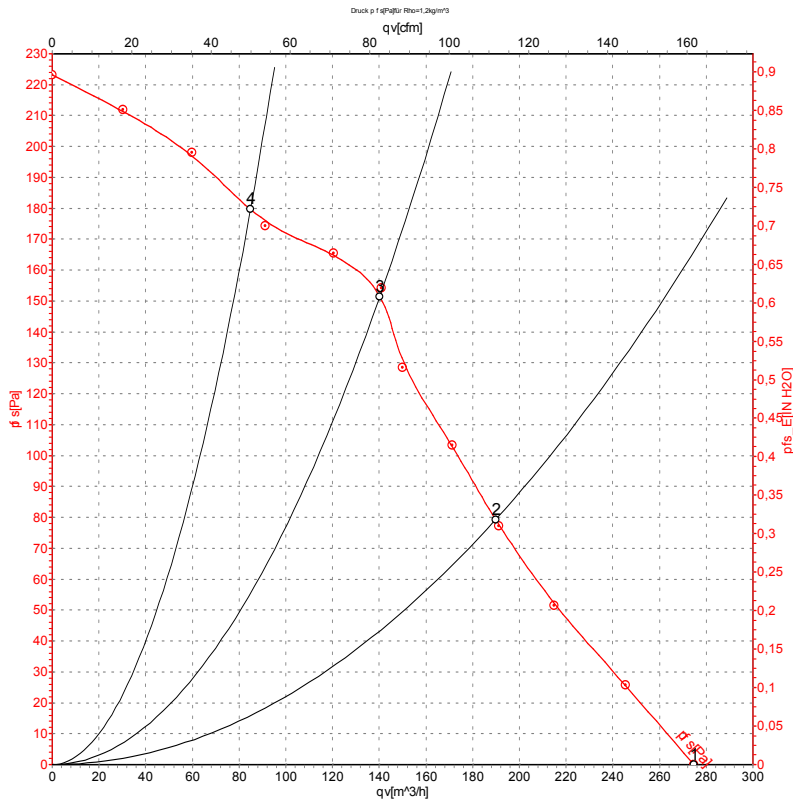

Measurement: LU-61438-1

Air performance measured according to ISO 5801 installation category A. For detailed information on the measurement setup, contact ebm-papst. Intake sound level: Sound power level according to ISO 13347 / sound pressure level measured at 1 m distance from fan axis. The values given are valid under the specified measuring conditions and may vary due to conditions of installation. For deviations from the standard configuration, the parameters have to be checked on the installed unit.

Measured values

| | U | f | n | P _e | I | q _v | P _{fs} | q _v | P _{fs} |
|---|-----|----|-------------------|----------------|------|-------------------|-----------------|----------------|--------------------|
| | V | Hz | min ⁻¹ | W | A | m ³ /h | Pa | cfm | inH ₂ O |
| 1 | 230 | 60 | 1820 | 47 | 0.21 | 275 | 0 | 160 | 0.00 |
| 2 | 230 | 60 | 1810 | 47 | 0.21 | 190 | 80 | 110 | 0.32 |
| 3 | 230 | 60 | 2080 | 46 | 0.21 | 140 | 150 | 80 | 0.60 |
| 4 | 230 | 60 | 2195 | 46 | 0.21 | 85 | 180 | 50 | 0.72 |

U = Power supply · f = Frequency · n = Speed (rpm) · P_e = Power consumption · I = Current draw · q_v = Air flow · P_{fs} = Pressure increase

