

R2E180-CB28-24 ebmpapst Datasheet

sales@fansco.com

www.fansco.com

Limited partnership · Headquarters Muldingen

Amtsgericht (court of registration) Stuttgart · HRA 590344

General partner Elektrobau Muldingen GmbH · Headquarters Muldingen

Amtsgericht (court of registration) Stuttgart · HRB 590142

Nominal data

Type	R2E180-CB28-24		
Motor	M2E068-BF		
Phase		1~	1~
Nominal voltage	VAC	230	230
Frequency	Hz	50	60
Method of obtaining data		fa	fa
Valid for approval/standard		CE	CE
Speed (rpm)	min ⁻¹	2550	2800
Power consumption	W	60	75
Current draw	A	0.28	0.33
Capacitor	µF	1.5	1.5
Capacitor voltage	VDB	450	450
Capacitor standard		S0 (CE)	S0 (CE)
Min. back pressure	Pa	0	0
Min. back pressure	inH2O	0	0
Min. ambient temperature	°C	-25	-25
Max. ambient temperature	°C	40	60
Starting current	A	0.45	0.45

ml = Max. load · me = Max. efficiency · fa = Free air · cs = Customer specification · ce = Customer equipment
Subject to change



Technical description

Weight	1.3 kg
Fan size	180 mm
Rotor surface	Painted black
Impeller material	PA plastic
Number of blades	16
Direction of rotation	Clockwise, viewed toward rotor
Degree of protection	IP44; installation- and position-dependent as per EN 60034-5
Insulation class	"B"
Moisture (F) / Environmental (H) protection class	H0+
Max. permitted ambient temp. for motor (transport/storage)	+ 80 °C
Min. permitted ambient temp. for motor (transport/storage)	- 40 °C
Installation position	Shaft horizontal or rotor on bottom; rotor on top on request
Condensation drainage holes	On rotor side
Mode	S1
Motor bearing	Ball bearing
Touch current according to IEC 60990 (measuring circuit Fig. 4, TN system)	< 0.75 mA
Motor protection	Thermal overload protector (TOP) internally connected
With cable	Variable
Protection class	I (with customer connection of protective earth)
Conformity with standards	EN 60335-1; CE
Approval	EAC

Product drawing

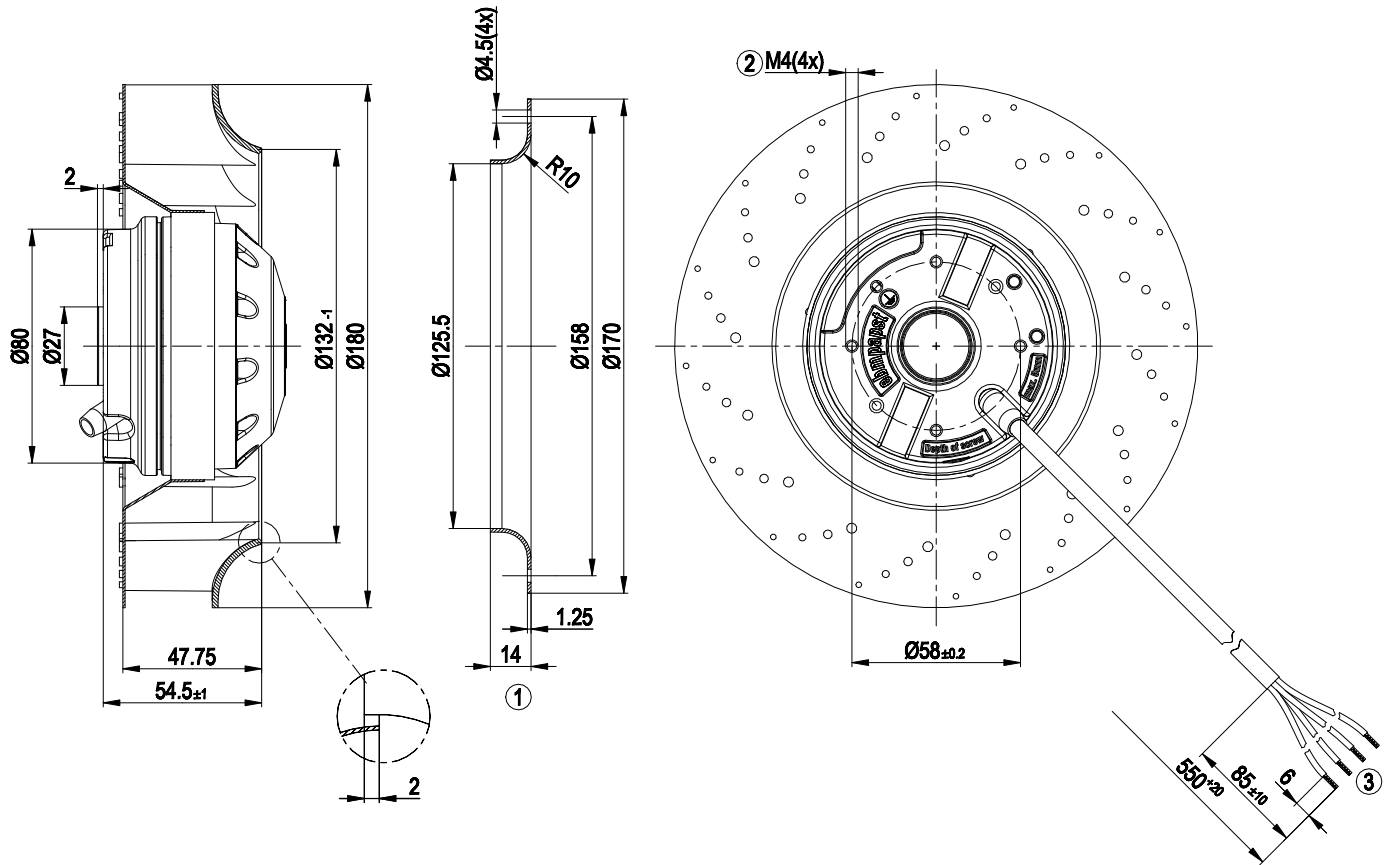

- 1 Accessory part: inlet ring 09576-2-4013, not included in scope of delivery
- 2 Max. clearance for screw 5 mm
- 3 Cable PVC 4G 0.5 mm², 4x crimped splices

Connection diagram



U1	blue	Z	brown	U2	black
PE	green/yellow				



Curves: Air performance 50 Hz

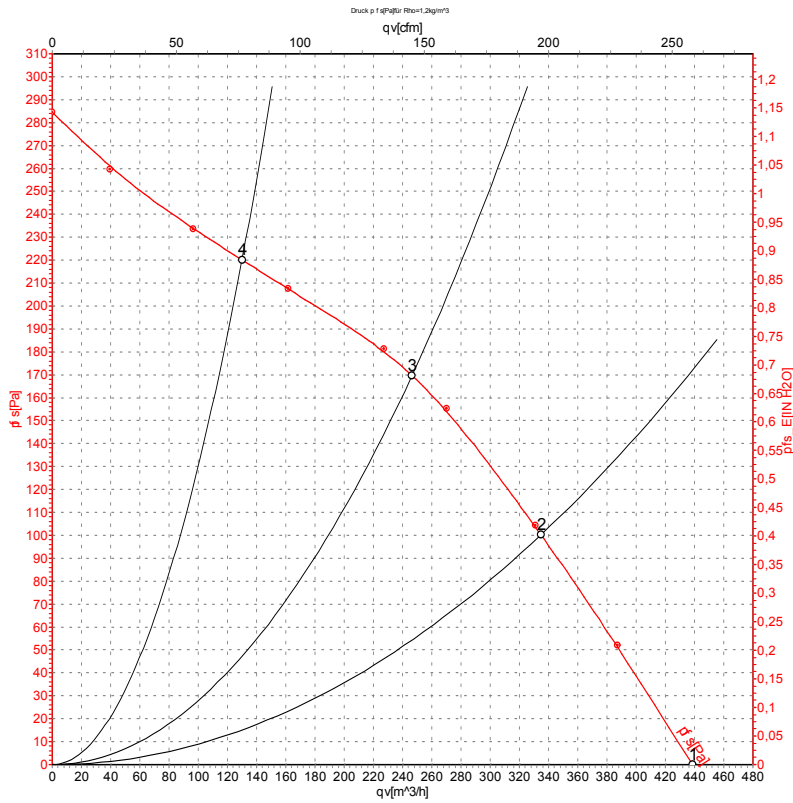

Measurement: LU-57242-1

Air performance measured according to ISO 5801 installation category A. For detailed information on the measurement setup, contact ebmpapst. Intake sound level: Sound power level according to ISO 13347 / sound pressure level measured at 1 m distance from fan axis. The values given are valid under the specified measuring conditions and may vary due to conditions of installation. For deviations from the standard configuration, the parameters have to be checked on the installed unit.

Measured values

	U	f	n	P _e	I	q _v	p _{fs}	q _v	p _{fs}
	V	Hz	min ⁻¹	W	A	m ³ /h	Pa	cfm	inH ₂ O
1	230	50	2550	60	0.28	440	0	260	0.00
2	230	50	2485	62	0.28	335	100	195	0.40
3	230	50	2535	60	0.27	245	170	145	0.68
4	230	50	2630	55	0.26	130	220	75	0.88

U = Power supply · f = Frequency · n = Speed (rpm) · P_e = Power consumption · I = Current draw · q_v = Air flow · p_{fs} = Pressure increase



Curves: Air performance 60 Hz

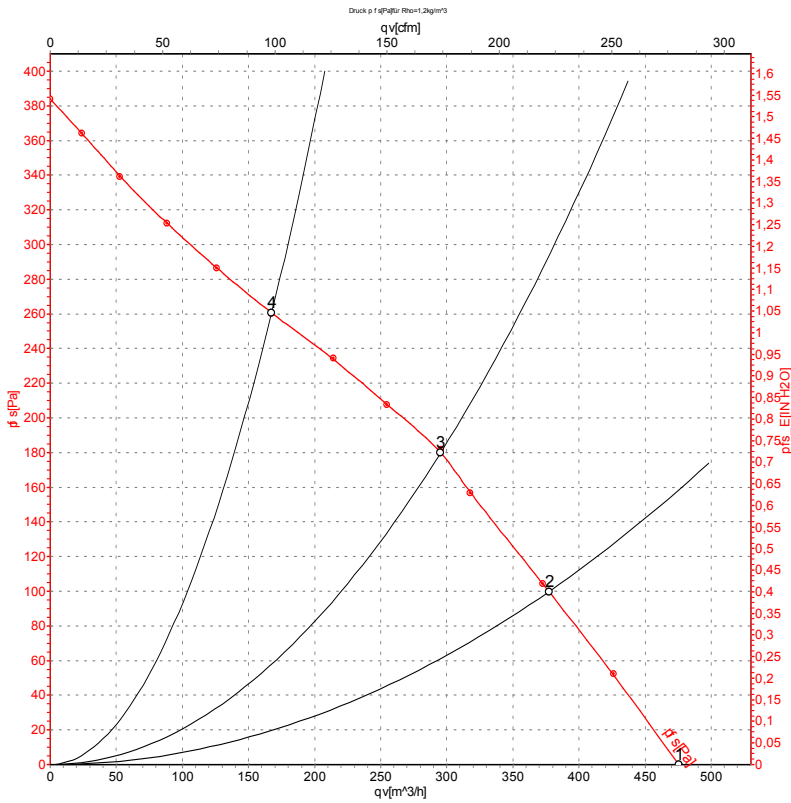

Measurement: LU-57243-1

Air performance measured according to ISO 5801 installation category A. For detailed information on the measurement setup, contact ebmpapst. Intake sound level: Sound power level according to ISO 13347 / sound pressure level measured at 1 m distance from fan axis. The values given are valid under the specified measuring conditions and may vary due to conditions of installation. For deviations from the standard configuration, the parameters have to be checked on the installed unit.

Measured values

	U	f	n	P _e	I	q _v	P _{fs}	q _v	P _{fs}
	V	Hz	min ⁻¹	W	A	m ³ /h	Pa	cfm	inH ₂ O
1	230	60	2800	75	0.33	475	0	280	0.00
2	230	60	2670	79	0.34	375	100	220	0.40
3	230	60	2725	77	0.33	295	180	175	0.72
4	230	60	2895	71	0.31	170	260	100	1.04

U = Power supply · f = Frequency · n = Speed (rpm) · P_e = Power consumption · I = Current draw · q_v = Air flow · P_{fs} = Pressure increase

