

R2E180-AH05-33 ebmpapst Datasheet
 sales@fansco.com
 www.fansco.com

Limited partnership · Headquarters Mulfingen
 Amtsgericht (court of registration) Stuttgart · HRA 590344
 General partner Elektrobau Mulfingen GmbH · Headquarters Mulfingen
 Amtsgericht (court of registration) Stuttgart · HRB 590142

Nominal data

Type	R2E180-AH05-33			
Motor	M2E068-DF			
Phase		1~	1~	1~
Nominal voltage	VAC	230	230	230
Frequency	Hz	50	60	60
Method of obtaining data		fa	fa	fa
Valid for approval/standard		CE	CE	UL
Speed (rpm)	min ⁻¹	2600	2850	2850
Power consumption	W	115	155	165
Current draw	A	0.51	0.68	0.7
Capacitor	µF	3	3	3
Capacitor voltage	VDB	400	400	400
Capacitor standard		S0 (CE)	S0 (CE)	UL
Min. back pressure	Pa		0	0
Min. back pressure	inH2O		0	0
Min. ambient temperature	°C	-25	-25	-25
Max. ambient temperature	°C	80	75	75

ml = Max. load · me = Max. efficiency · fa = Free air · cs = Customer specification · ce = Customer equipment
 Subject to change



Technical description

Weight	2.9 kg
Fan size	180 mm
Rotor surface	Unpainted
Motor suspension	Motor mounted with brackets on one side
Direction of rotation	Counterclockwise, viewed toward rotor
Degree of protection	IP20
Insulation class	"B"
Moisture (F) / Environmental (H) protection class	H0 - dry environment
Max. permitted ambient temp. for motor (transport/storage)	+ 80 °C
Min. permitted ambient temp. for motor (transport/storage)	- 40 °C
Installation position	Shaft horizontal
Condensation drainage holes	None
Mode	S1
Motor bearing	Ball bearing
Touch current according to IEC 60990 (measuring circuit Fig. 4, TN system)	< 0.75 mA
Electrical hookup	Via terminal strip
Motor protection	Thermal overload protector (TOP) internally connected
With cable	Axial
Protection class	I (if protective earth is connected by customer to the housing's connection point)
Conformity with standards	EN 60335-1; CE
Approval	UL 1004-3; CSA C22.2 No. 77; EAC

Product drawing

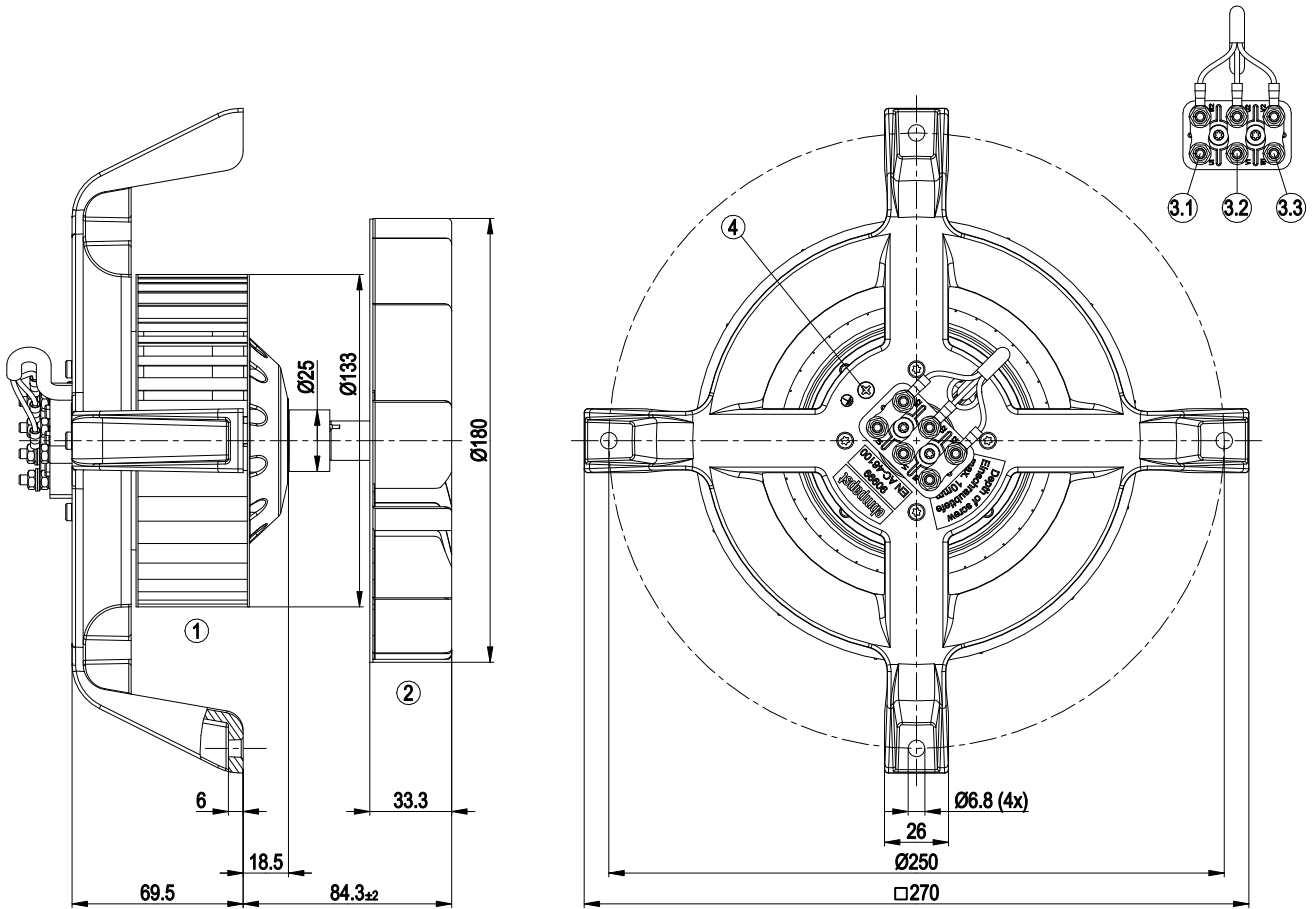

1	Centrifugal fan impeller (sheet steel, galvanized)
2	Centrifugal fan impeller (sheet steel, rust- and acid-resistant)
3.1	L (blue)
3.2	N (black)
3.3	Z (brown)
4	M4 screw for fastening ground connector
	Max. clearance for screw 5 mm

Connection diagram

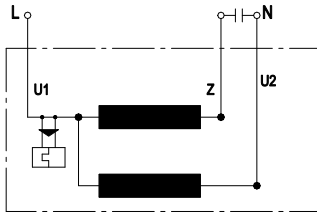

U1	blue	Z	brown	U2	black
----	------	---	-------	----	-------



Curves: Air performance 50 Hz

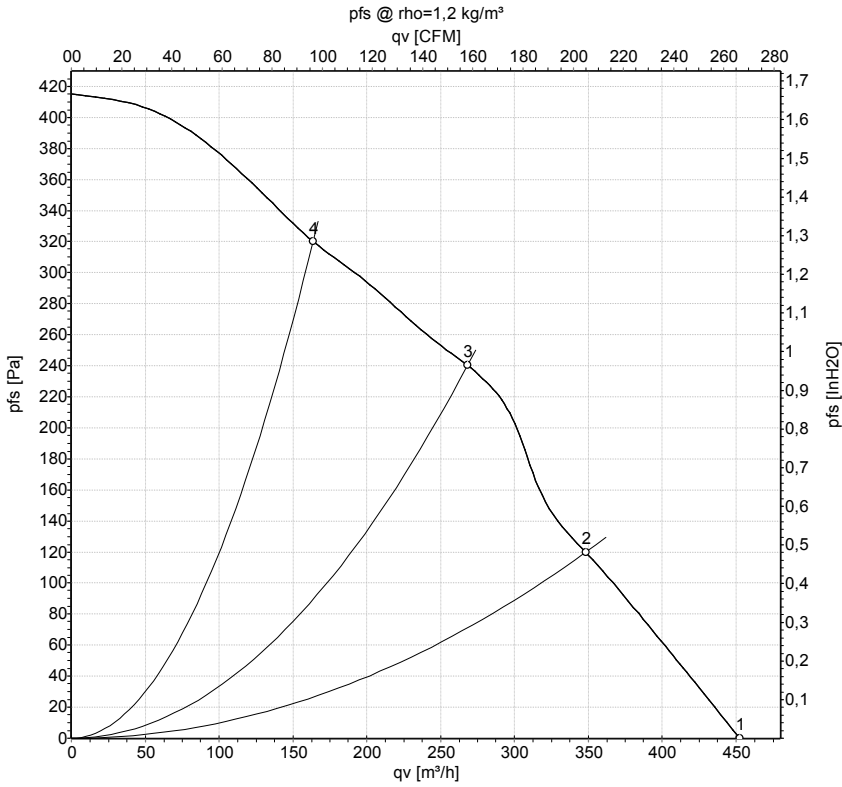

Measurement: LU-156453-1

Air performance measured according to ISO 5801 installation category A. For detailed information on the measurement setup, contact ebm-papst. Intake sound level: Sound power level according to ISO 13347 / sound pressure level measured at 1 m distance from fan axis. The values given are valid under the specified measuring conditions and may vary due to conditions of installation. For deviations from the standard configuration, the parameters have to be checked on the installed unit.

Measured values

	U	f	n	P _e	I	q _v	p _{fs}	q _v	p _{fs}
	V	Hz	min ⁻¹	W	A	m³/h	Pa	cfm	inH2O
1	230	50	2600	115	0.51	450	0	265	0.00
2	230	50	2610	108	0.49	350	120	205	0.48
3	230	50	2630	104	0.48	270	240	160	0.96
4	230	50	2645	102	0.47	165	320	95	1.28

U = Power supply · f = Frequency · n = Speed (rpm) · P_e = Power consumption · I = Current draw · q_v = Air flow · p_{fs} = Pressure increase



Curves: Air performance 60 Hz

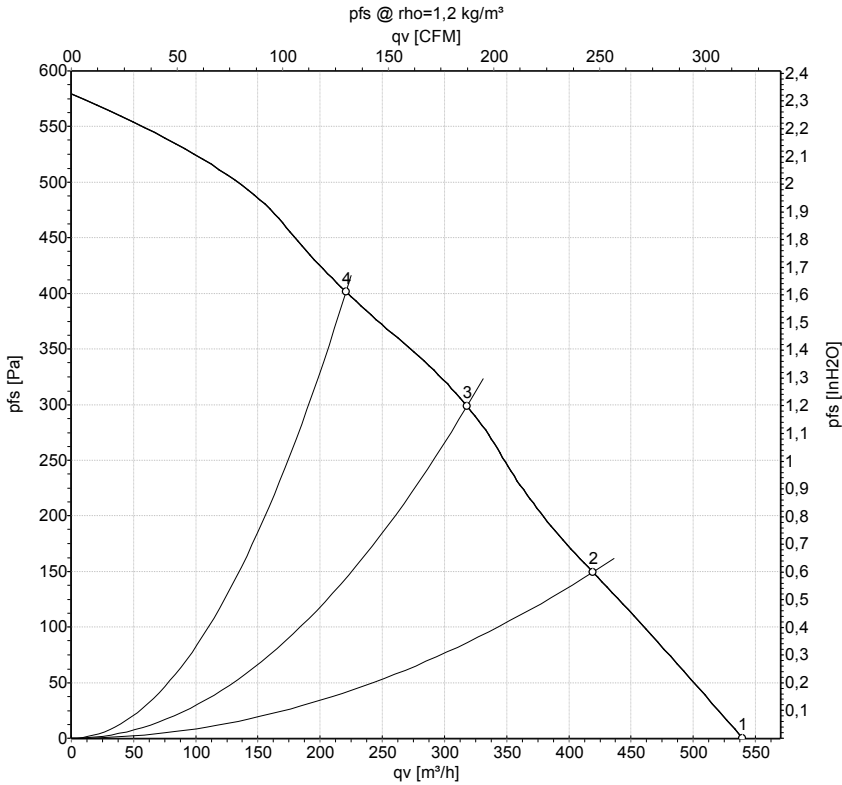

Measurement: LU-10720-1

Air performance measured according to ISO 5801 installation category A. For detailed information on the measurement setup, contact ebm-papst. Intake sound level: Sound power level according to ISO 13347 / sound pressure level measured at 1 m distance from fan axis. The values given are valid under the specified measuring conditions and may vary due to conditions of installation. For deviations from the standard configuration, the parameters have to be checked on the installed unit.

Measured values

	U	f	n	P_e	I	q_v	P_{fs}	q_v	P_{fs}
	V	Hz	min ⁻¹	W	A	m³/h	Pa	cfm	inH2O
1	230	60	2850	155	0.68	540	0	315	0.00
2	230	60	2915	152	0.66	420	150	245	0.60
3	230	60	2975	146	0.63	320	300	185	1.20
4	230	60	3010	143	0.62	220	400	130	1.61

U = Power supply · f = Frequency · n = Speed (rpm) · P_e = Power consumption · I = Current draw · q_v = Air flow · P_{fs} = Pressure increase

