

R2E175-RA66-11 ebmpapst Datasheet

sales@fansco.com

www.fansco.com

Limited partnership · Headquarters Muldingen  
 County court Stuttgart · HRA 590344

General partner Elektrobau Muldingen GmbH · Headquarters Muldingen  
 County court Stuttgart · HRB 590142

## Nominal data

<b>Type</b>	<b>R2E175-RA66-11</b>	
<b>Motor</b>	<b>M2E052-CA</b>	
Phase		1~
Nominal voltage	VAC	115
Frequency	Hz	60
Type of data definition		ml
Valid for approval / standard		CE
Speed (rpm)	min <sup>-1</sup>	2800
Power input	W	58
Current draw	A	0.52
Motor capacitor	µF	5
Capacitor voltage	VDB	220
Capacitor standard		S0 (CE)
Min. back pressure	Pa	0
Min. ambient temperature	°C	-25
Max. ambient temperature	°C	50
Starting current	A	0.73

ml = Max. load · me = Max. efficiency · fa = Running at free air · cs = Customer specs · cu = Customer unit  
 Subject to alterations



### Technical features

Mass	0.9 kg
Size	175 mm
Surface of rotor	Uncoated
Material of impeller	PA plastic
Number of blades	7
Direction of rotation	Clockwise, seen on rotor
Type of protection	IP 44; Depending on installation and position
Insulation class	"B"
Humidity (F)/environmental protection class (H)	F0
Max. permissible ambient motor temp. (transp./ storage)	+ 80 °C
Min. permissible ambient motor temp. (transp./storage)	- 40 °C
Mounting position	Any
Condensate discharge holes	None
Operation mode	S1
Motor bearing	Ball bearing
Touch current acc. IEC 60990 (measuring network Fig. 4, TN system)	< 0.75 mA
Motor protection	Thermal overload protector (TOP) wired internally
Cable exit	Variable
Protection class	I (if protective earth is connected by customer)
Product conforming to standard	CE
Approval	CSA C22.2 No.100; UL 1004-1

## Product drawing

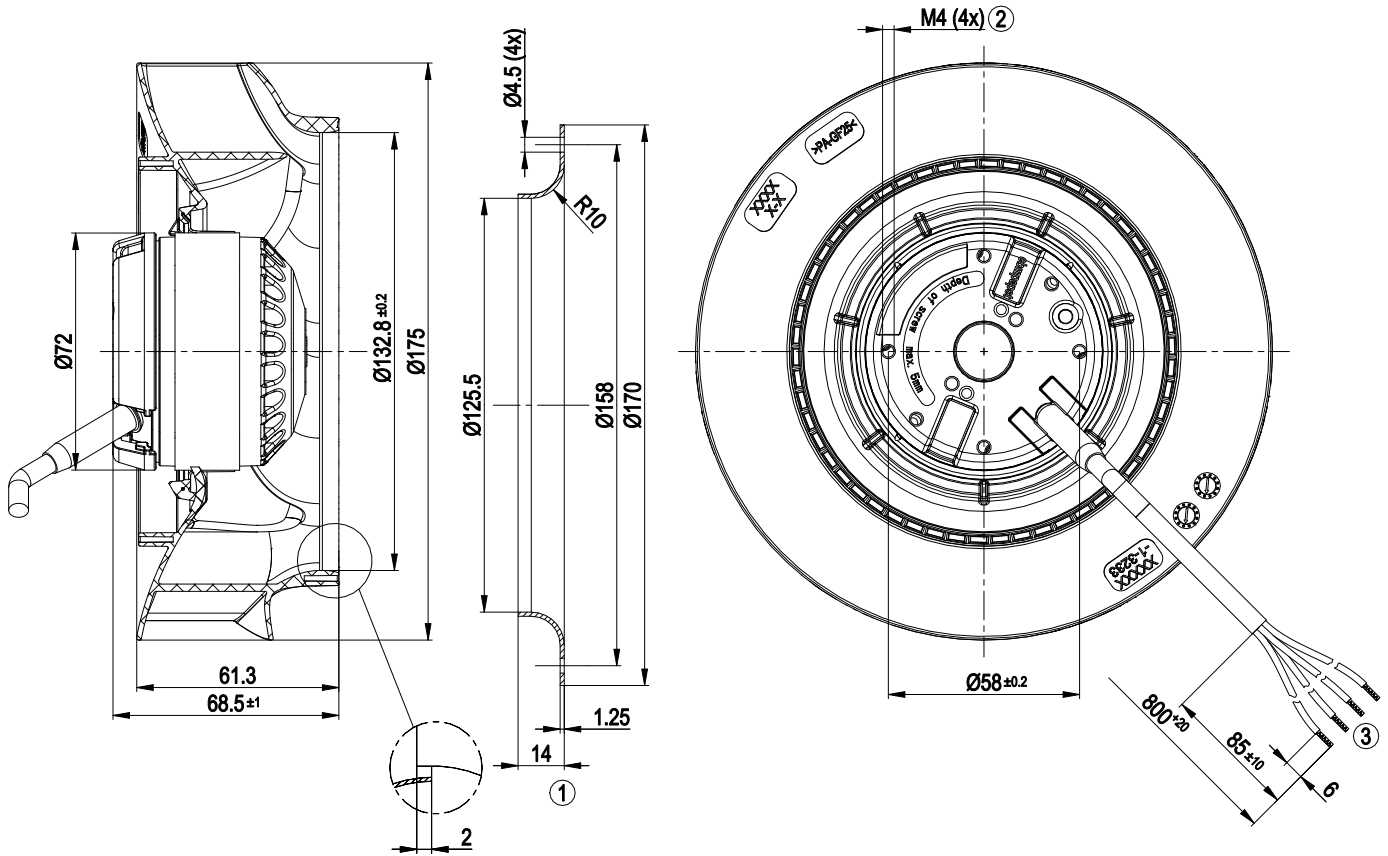

- 1 Accessory part: Inlet nozzle 09576-2-4013 not included in scope of delivery
- 2 Thread reach max. 5 mm
- 3 Connection line PVC AWG20, 4x lead tips crimped

## Connection screen



U1	blue	Z	brown	U2	black
PE	green/yellow				

## Charts: Air flow 60 Hz

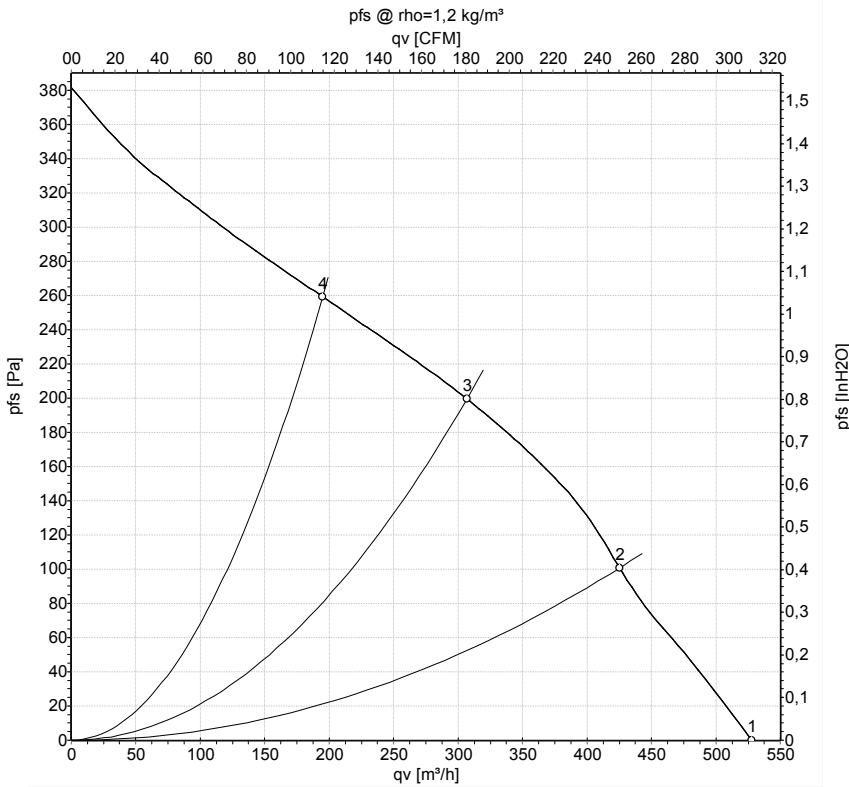

Measurement: LU-158373-1

Air performance measured as per ISO 5801 Installation category A. For detailed information on the measuring set-up, please contact ebm-papst. Suction-side noise levels: LwA measured as per ISO 13347 / LpA measured with 1m distance to fan axis. The values given are valid under the measuring conditions mentioned above and may vary according to the actual installation situation. With any deviation from the standard set-up, the specific values have to be checked and reviewed with the unit installed.

## Measured values

	U	f	n	P <sub>e</sub>	I	q <sub>v</sub>	p <sub>fs</sub>	q <sub>v</sub>	p <sub>fs</sub>
	V	Hz	min <sup>-1</sup>	W	A	m <sup>3</sup> /h	Pa	cfm	inH2O
1	115	60	2955	53	0.48	530	0	310	0.00
2	115	60	2840	56	0.50	425	100	250	0.40
3	115	60	2800	58	0.52	305	200	180	0.80
4	115	60	2845	56	0.50	195	260	115	1.04

U = Supply voltage · f = Frequency · n = Speed (rpm) · P<sub>e</sub> = Power input · I = Current draw · q<sub>v</sub> = Air flow · p<sub>fs</sub> = Pressure increase

