

R2E160-BM50-09 ebmpapst Datasheet

sales@fansco.com

www.fansco.com

Limited partnership · Headquarters Muldingen
County court Stuttgart · HRA 590344General partner Elektrobau Muldingen GmbH · Headquarters Muldingen
County court Stuttgart · HRB 590142

Nominal data

Type	R2E160-BM50-09			
Motor	M2E068-EC			
Phase		1~	1~	1~
Nominal voltage	VAC	230	230	230
Frequency	Hz	50	60	60
Type of data definition		ml	ml	ml
Valid for approval / standard		CE	CE	UL 2111
Speed (rpm)	min ⁻¹	2400	2850	2850
Power input	W	230	260	270
Current draw	A	1.02	1.14	1.2
Motor capacitor	µF	5	6	6
Capacitor voltage	VDB	400	400	400
Capacitor standard		S0 (CE)	S0 (CE)	S0 (CE)
Min. back pressure	Pa	140	530	530
Min. ambient temperature	°C	-25	-25	-25
Max. ambient temperature	°C	30	30	30

ml = Max. load · me = Max. efficiency · fa = Running at free air · cs = Customer specs · cu = Customer unit
Subject to alterations

Data according to ErP directive

		Actual	Request 2015
01 Overall efficiency η_{es}	%	32.3	32.3
02 Measurement category		A	
03 Efficiency category		Static	
04 Efficiency grade N		44	44
05 Variable speed drive		No	

Data definition with optimum efficiency.
The ErP data is determined using a motor-impeller combination in a standardised measurement configuration.

09 Power input P_e	kW	0.14
09 Air flow q_v	m ³ /h	335
09 Pressure increase p_{fs}	Pa	498
10 Speed (rpm) n	min ⁻¹	2735
11 Specific ratio*		1.00

* Specific ratio = $1 + p_{fs} / 100\,000\text{ Pa}$

LU-159463



Technical features

Mass	2.5 kg
Size	160 mm
Surface of rotor	Uncoated
Material of impeller	PA plastic
Direction of rotation	Clockwise, seen on rotor
Type of protection	IP 44; Depending on installation and position
Insulation class	"B"
Humidity (F)/environmental protection class (H)	H0 - dry environment
Max. permissible ambient motor temp. (transp./ storage)	+ 80 °C
Min. permissible ambient motor temp. (transp./storage)	- 40 °C
Mounting position	Any
Condensate discharge holes	None
Operation mode	S1
Motor bearing	Ball bearing
Touch current acc. IEC 60990 (measuring network Fig. 4, TN system)	< 0.75 mA
Motor protection	Thermal overload protector (TOP) wired internally
Cable exit	Variable
Protection class	I (if protective earth is connected by customer)
Product conforming to standard	EN 60335-1; CE
Approval	UL 2111; CSA C22.2 No.77

Product drawing

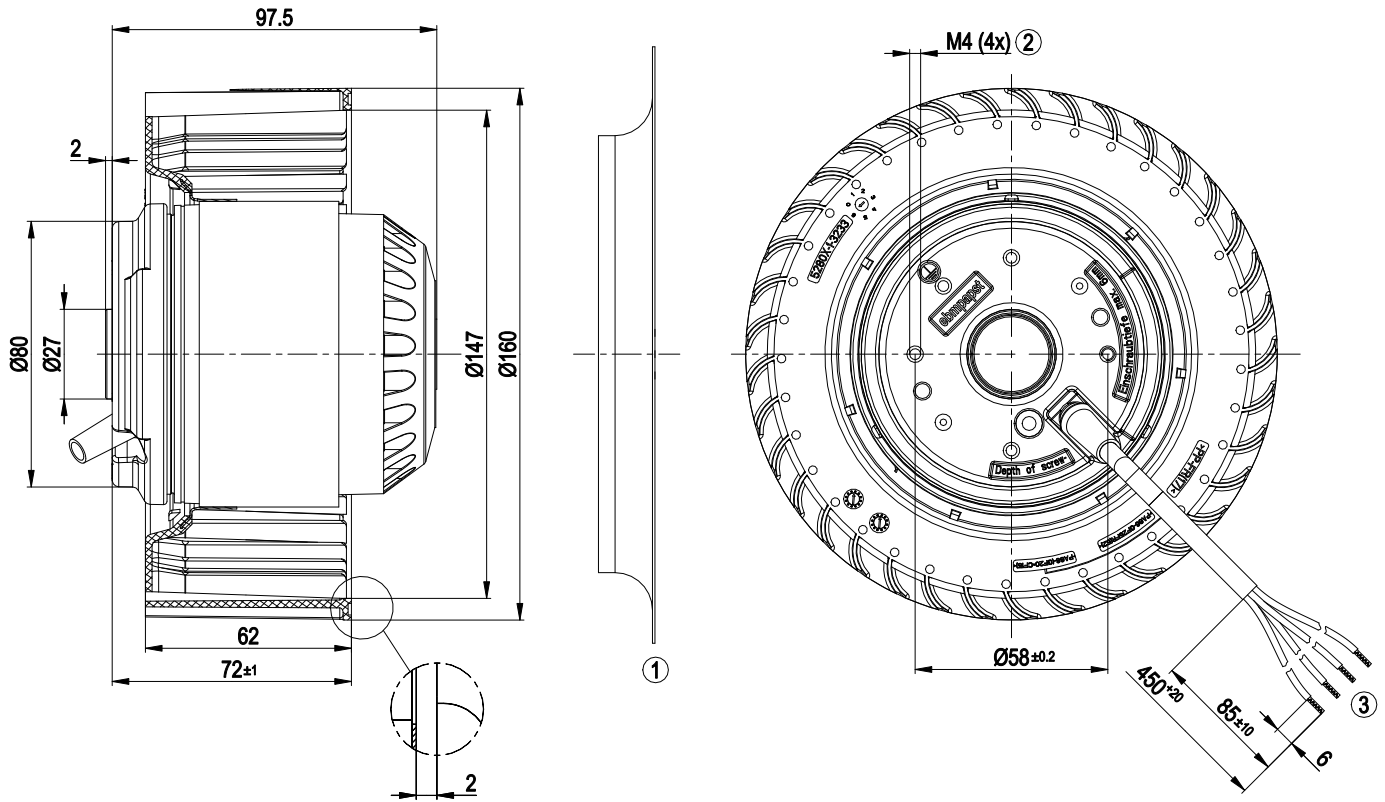

- | | |
|---|---|
| 1 | Accessory part: Inlet nozzle 09588-2-4013 not included in scope of delivery |
| 2 | Thread reach max. 6 mm |
| 3 | Connection line PVC AWG20, 4x lead tips crimped |

Accessory part

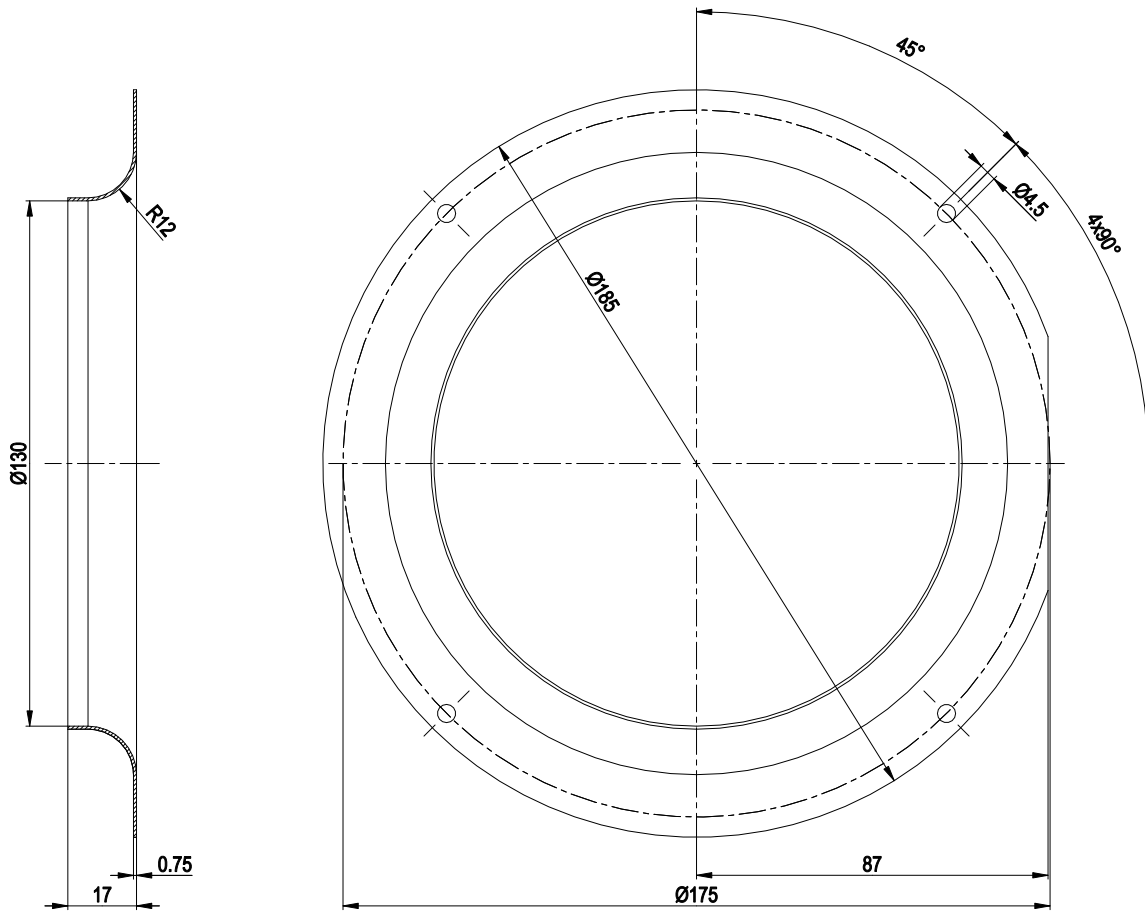

Accessory part: inlet nozzle 09588-2-4013 not included in scope of delivery

Connection screen

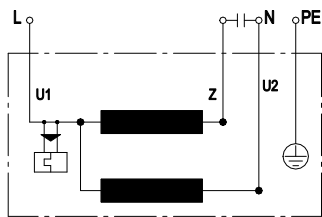

U1	blue	Z	brown	U2	black
PE	green/yellow				

Charts: Air flow 50 Hz

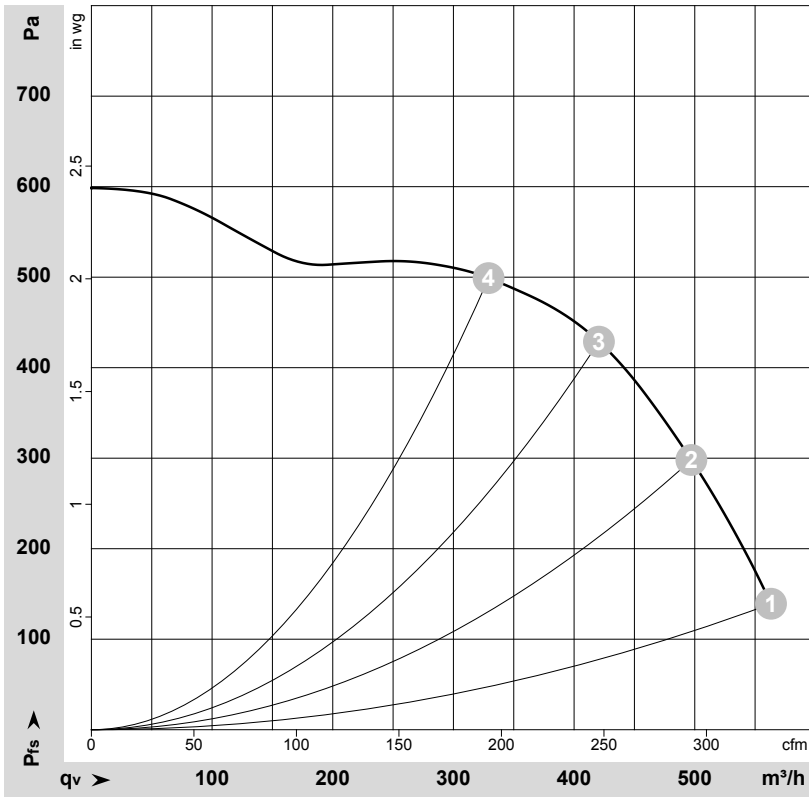

$\rho = 1.15 \text{ kg/m}^3 \pm 2 \%$

Measurement: LU-159463-1

Air performance measured as per ISO 5801 Installation category A. For detailed information on the measuring set-up, please contact ebmpapst. Suction-side noise levels: LwA measured as per ISO 13347 / LpA measured with 1m distance to fan axis. The values given are valid under the measuring conditions mentioned above and may vary according to the actual installation situation. With any deviation from the standard set-up, the specific values have to be checked and reviewed with the unit installed.

Measured values

	U	f	n	P _e	I	LpA _{in}	LwA _{in}	q _v	P _{fs}	q _v	P _{fs}
	V	Hz	min ⁻¹	W	A	dB(A)	dB(A)	m ³ /h	Pa	cfm	inH2O
1	230	50	2400	230	1.02	70	77	565	140	330	0.56
2	230	50	2530	201	0.88	69	76	495	300	295	1.20
3	230	50	2640	173	0.76	68	74	420	430	250	1.73
4	230	50	2740	144	0.64	66	73	330	500	195	2.01

U = Supply voltage · f = Frequency · n = Speed (rpm) · P_e = Power input · I = Current draw · LpA_{in} = Sound pressure level inlet side · LwA_{in} = Sound power level inlet side · q_v = Air flow
P_{fs} = Pressure increase



Charts: Air flow 60 Hz

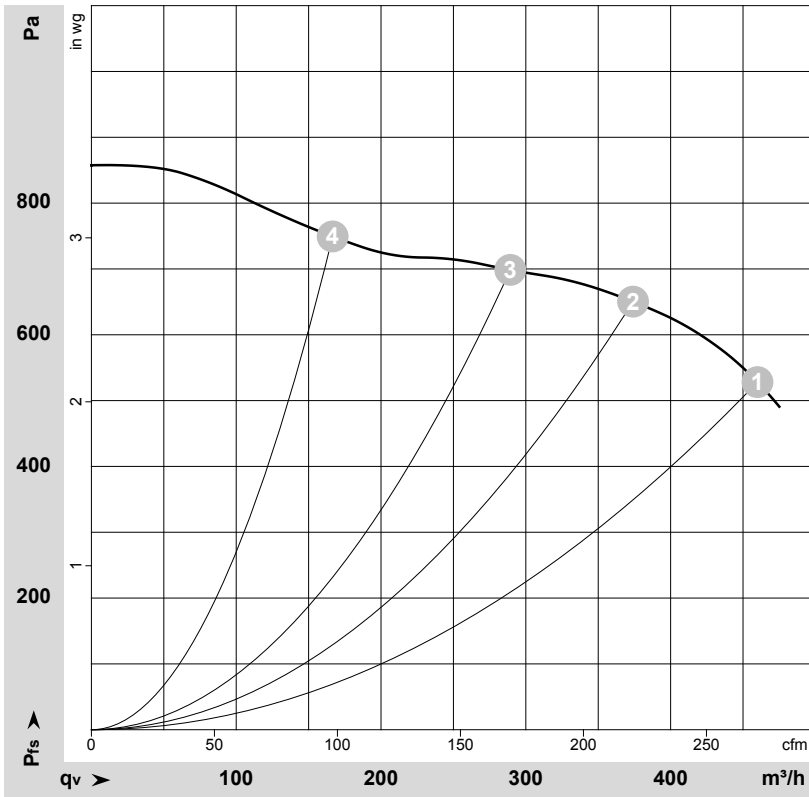

$\rho = 1.15 \text{ kg/m}^3 \pm 2 \%$

Measurement: LU-159837-1

Air performance measured as per ISO 5801 Installation category A. For detailed information on the measuring set-up, please contact ebmpapst. Suction-side noise levels: LwA measured as per ISO 13347 / LpA measured with 1m distance to fan axis. The values given are valid under the measuring conditions mentioned above and may vary according to the actual installation situation. With any deviation from the standard set-up, the specific values have to be checked and reviewed with the unit installed.

Measured values

	U	f	n	P _e	I	q _v	P _{fs}	q _v	P _{fs}
	V	Hz	min ⁻¹	W	A	m ³ /h	Pa	cfm	inH ₂ O
1	230	60	2850	260	1.14	460	530	270	2.13
2	230	60	3105	222	0.99	375	650	220	2.61
3	230	60	3245	189	0.86	290	700	170	2.81
4	230	60	3345	162	0.76	165	750	100	3.01

U = Supply voltage · f = Frequency · n = Speed (rpm) · P_e = Power input · I = Current draw · q_v = Air flow · P_{fs} = Pressure increase

