

for solid-fuel heating systems

R2E160-BK82-12 ebmpapst Datasheet

sales@fansco.com

www.fansco.com

Limited partnership · Headquarters Mulfingen

Amtsgericht (court of registration) Stuttgart · HRA 590344

General partner Elektrobau Mulfingen GmbH · Headquarters Mulfingen

Amtsgericht (court of registration) Stuttgart · HRB 590142

Nominal data

Type	R2E160-BK82-12	
Motor	M2E068-CF	
Phase		1~
Nominal voltage	VAC	230
Frequency	Hz	50
Method of obtaining data		fa
Valid for approval/standard		CE
Speed (rpm)	min ⁻¹	2700
Power consumption	W	51
Current draw	A	0.24
Capacitor	µF	2
Capacitor voltage	VDB	400
Capacitor standard		S0 (CE)
Min. back pressure	Pa	0
Min. back pressure	inH ₂ O	0
Min. ambient temperature	°C	-25
Max. ambient temperature	°C	80
Starting current	A	0.61

ml = Max. load · me = Max. efficiency · fa = Free air · cs = Customer specification · ce = Customer equipment
Subject to change



Technical description

Weight	3.5 kg
Fan size	160 mm
Rotor surface	Unpainted
Impeller material	Sheet steel, rust-resistant
Number of blades	6
Motor suspension	Motor mounted on brackets for one-sided vibration damping
Direction of rotation	Counterclockwise, viewed toward rotor
Degree of protection	IP44; installation- and position-dependent
Insulation class	"F"
Moisture (F) / Environmental (H) protection class	H0 - dry environment
Max. permitted ambient temp. for motor (transport/storage)	+ 80 °C
Min. permitted ambient temp. for motor (transport/storage)	- 40 °C
Installation position	Any
Condensation drainage holes	None
Mode	S1
Motor bearing	Ball bearing
Touch current according to IEC 60990 (measuring circuit Fig. 4, TN system)	< 0.75 mA
Electrical hookup	With plug
Motor protection	Thermal overload protector (TOP) internally connected
With cable	Variable
Protection class	I (with customer connection of protective earth)
Motor capacitor according to EN 60252-1 in safety protection class	S0
Conformity with standards	EN 60335-1; CE

Product drawing

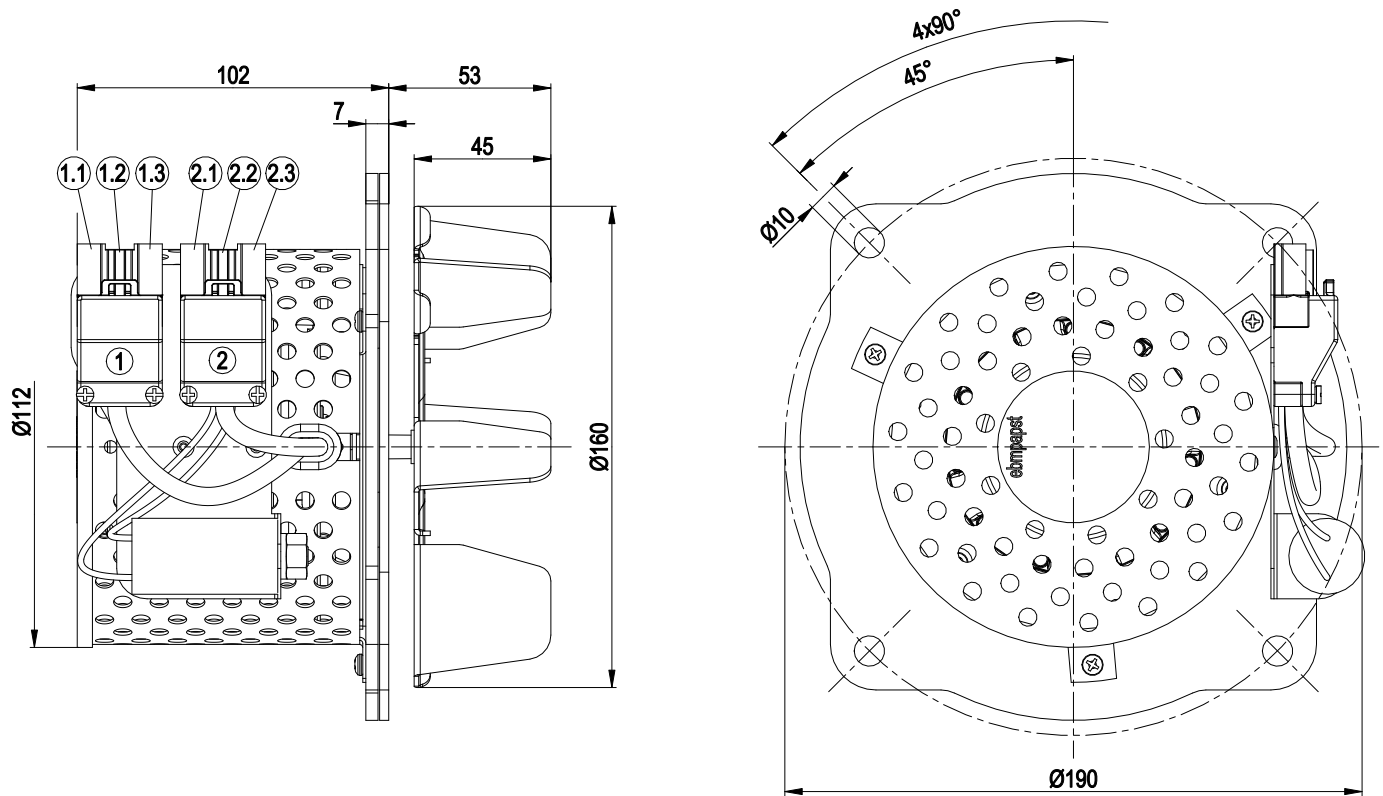

1	3-pole connector housing Wieland 93.631.4757.0
1.1	VCC (red) +5 V
1.2	GND (black)
1.3	out (white)
2	3-pole connector housing Wieland 93.631.4257.0
2.1	N (black)
2.2	PE (yellow/green)
2.3	L (blue)

Connection diagram

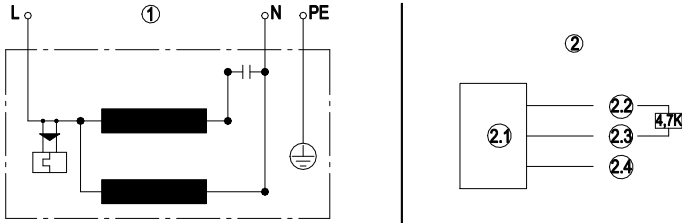

1	Fan connection diagram
L	blue
N	black
PE	green/yellow
2	Hall IC circuit
2.1	Hall IC
2.2	red (+5 V)
2.3	white (out)
2.4	black (0 V)



Curves: Air performance 50 Hz

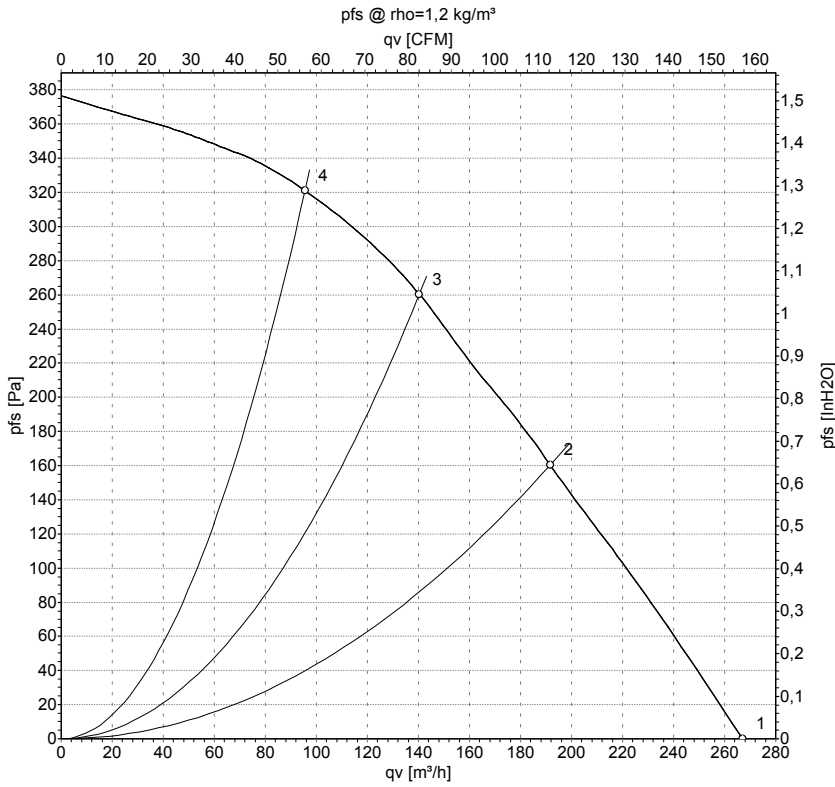

Measurement: LU-134945-1

Air performance measured according to ISO 5801 installation category A. For detailed information on the measurement setup, contact ebm-papst. Intake sound level: Sound power level according to ISO 13347 / sound pressure level measured at 1 m distance from fan axis. The values given are valid under the specified measuring conditions and may vary due to conditions of installation. For deviations from the standard configuration, the parameters have to be checked on the installed unit.

Measured values

	U	f	n	P _e	I	q _v	p _{fs}	q _v	p _{fs}
	V	Hz	min ⁻¹	W	A	m³/h	Pa	cfm	inH2O
1	230	50	2700	51	0.24	265	0	155	0.00
2	230	50	2750	48	0.21	190	160	115	0.64
3	230	50	2765	46	0.21	140	260	80	1.04
4	230	50	2785	44	0.20	95	320	55	1.28

U = Power supply · f = Frequency · n = Speed (rpm) · P_e = Power consumption · I = Current draw · q_v = Air flow · p_{fs} = Pressure increase

