

R2E160-BI82-13 ebmpapst Datasheet
 sales@fansco.com
 www.fansco.com

Limited partnership · Headquarters Muldingen
 Amtsgericht (court of registration) Stuttgart · HRA 590344
 General partner Elektrobau Muldingen GmbH · Headquarters Muldingen
 Amtsgericht (court of registration) Stuttgart · HRB 590142

Nominal data

Type	R2E160-BI82-13	
Motor	M2E068-CF	
Phase		1~
Nominal voltage	VAC	230
Frequency	Hz	50
Method of obtaining data		fa
Valid for approval/standard		CE
Speed (rpm)	min ⁻¹	2750
Power consumption	W	50
Current draw	A	0.23
Capacitor	µF	2
Capacitor voltage	VDB	400
Capacitor standard		S0 (CE)
Min. back pressure	Pa	0
Min. back pressure	inH2O	0
Min. ambient temperature	°C	-25
Max. ambient temperature	°C	60

ml = Max. load · me = Max. efficiency · fa = Free air · cs = Customer specification · ce = Customer equipment
 Subject to change



Technical description

Weight	3.4 kg
Fan size	160 mm
Rotor surface	Unpainted
Impeller material	Sheet steel, rust-resistant
Number of blades	6
Direction of rotation	Counterclockwise, viewed toward rotor
Degree of protection	IP44; installation- and position-dependent
Insulation class	"F"
Moisture (F) / Environmental (H) protection class	H0 - dry environment
Max. permitted ambient temp. for motor (transport/storage)	+ 80 °C
Min. permitted ambient temp. for motor (transport/storage)	- 40 °C
Installation position	Any
Condensation drainage holes	None
Mode	S1
Motor bearing	Ball bearing
Touch current according to IEC 60990 (measuring circuit Fig. 4, TN system)	< 0.75 mA
Motor protection	Thermal overload protector (TOP) internally connected
With cable	Variable
Protection class	I (with customer connection of protective earth)
Motor capacitor according to EN 60252-1 in safety protection class	S0
Conformity with standards	EN 60335-1; CE



Product drawing

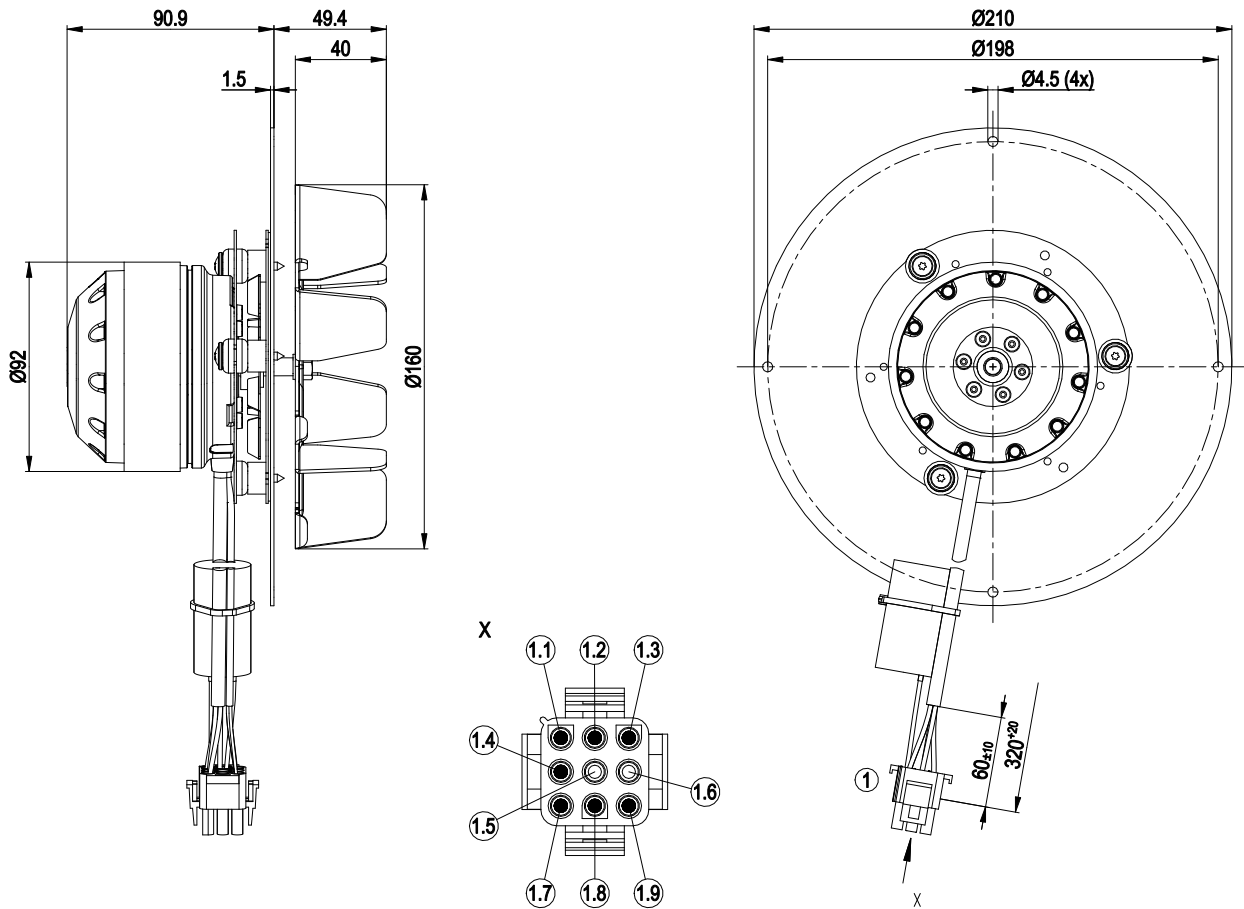

1	Cable silicone 4G 0.5 mm ² , cable Raychem Spec. 44 AWG24, 1x 9-pole connector housing Tyco 1863003-1, 4x socket Tyco 926882-1, 3x socket Tyco 350925-1
1.1	black + capacitor
1.2	blue
1.3	green/yellow
1.4	brown + capacitor
1.5	not used
1.6	not used
1.7	red (Hall IC)
1.8	white (Hall IC)
1.9	black (Hall IC)



Connection diagram

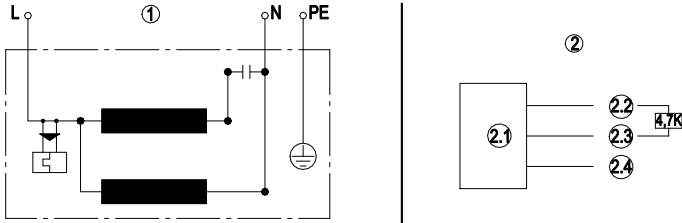

1	Fan connection diagram
L	blue
N	black
PE	green/yellow
2	Hall IC circuit
2.1	Hall IC
2.2	red (+5 V)
2.3	white (out)
2.4	black (0 V)



Curves: Air performance 50 Hz

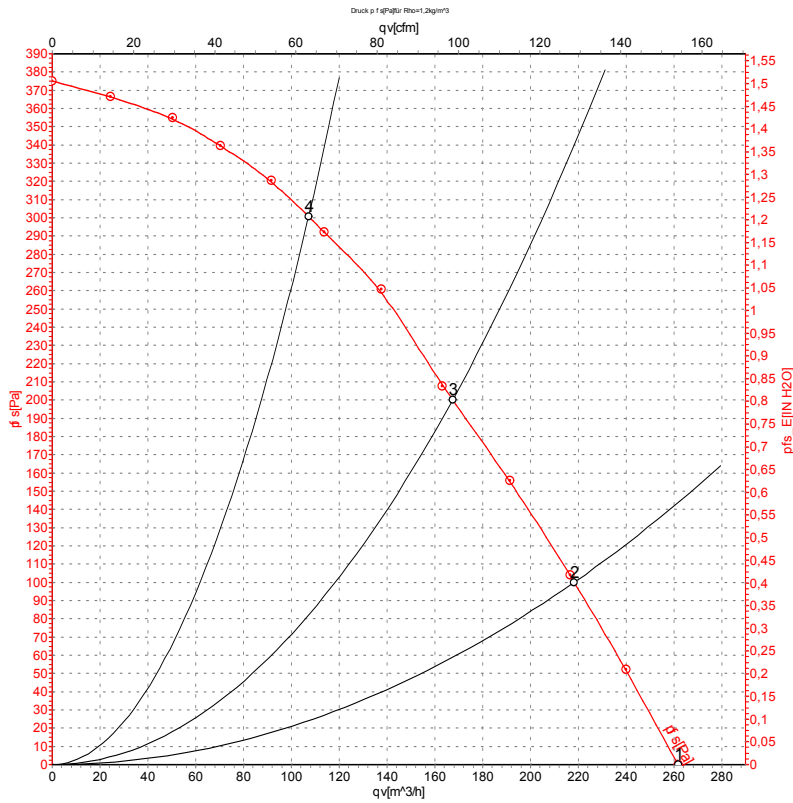

Measurement: LU-119166-1

Air performance measured according to ISO 5801 installation category A. For detailed information on the measurement setup, contact ebmpapst. Intake sound level: Sound power level according to ISO 13347 / sound pressure level measured at 1 m distance from fan axis. The values given are valid under the specified measuring conditions and may vary due to conditions of installation. For deviations from the standard configuration, the parameters have to be checked on the installed unit.

Measured values

	U	f	n	P _e	I	q _v	P _{fs}	q _v	P _{fs}
	V	Hz	min ⁻¹	W	A	m ³ /h	Pa	cfm	inH2O
1	230	50	2750	50	0.23	260	0	155	0.00
2	230	50	2780	46	0.20	220	100	130	0.40
3	230	50	2790	45	0.20	170	200	100	0.80
4	230	50	2810	43	0.19	105	300	65	1.20

U = Power supply · f = Frequency · n = Speed (rpm) · P_e = Power consumption · I = Current draw · q_v = Air flow · P_{fs} = Pressure increase

