

R2E160-AY50-30 ebmpapst Datasheet

sales@fansco.com

www.fansco.com

Limited partnership · Headquarters Muldingen

Amtsgericht (court of registration) Stuttgart · HRA 590344

General partner Elektrobau Muldingen GmbH · Headquarters Muldingen

Amtsgericht (court of registration) Stuttgart · HRB 590142

Nominal data

Type	R2E160-AY50-30	
Motor	M2E068-EC	
Phase		1~
Nominal voltage	VAC	230
Frequency	Hz	50
Method of obtaining data		ml
Valid for approval/standard		CE
Speed (rpm)	min ⁻¹	2400
Power consumption	W	230
Current draw	A	0.99
Capacitor	µF	5
Capacitor voltage	VDB	400
Min. back pressure	Pa	250
Min. back pressure	inH ₂ O	1
Min. ambient temperature	°C	-25
Max. ambient temperature	°C	60
Starting current	A	1.7

ml = Max. load · me = Max. efficiency · fa = Free air · cs = Customer specification · ce = Customer equipment
Subject to change

Data according to Commission Regulation (EU) 327/2011

		Actual	Req. 2015			
01 Overall efficiency η_{es}	%	32.1	32.1	09 Power consumption P_e	kW	0.13
02 Measurement category		A		09 Air flow q_v	m ³ /h	300
03 Efficiency category		Static		09 Pressure increase p_{fs}	Pa	527
04 Efficiency grade N		44	44	10 Speed (rpm) n	min ⁻¹	2745
05 Variable speed drive		No		11 Specific ratio*		1.01

Data obtained at optimum efficiency level.

The ErP data is determined using a motor-impeller combination in a standardized measurement setup.

* Specific ratio = $1 + p_{fs} / 100\,000\text{ Pa}$

LU-140176



Technical description

Weight	2.7 kg
Fan size	160 mm
Rotor surface	Unpainted
Impeller material	Sheet steel, galvanized
Direction of rotation	Counterclockwise, viewed toward rotor
Degree of protection	IP44; installation- and position-dependent
Insulation class	"F"
Moisture (F) / Environmental (H) protection class	H0 - dry environment
Max. permitted ambient temp. for motor (transport/storage)	+ 80 °C
Min. permitted ambient temp. for motor (transport/storage)	- 40 °C
Installation position	Any
Condensation drainage holes	None
Mode	S1
Motor bearing	Ball bearing
Touch current according to IEC 60990 (measuring circuit Fig. 4, TN system)	< 0.75 mA
Motor protection	Thermal overload protector (TOP) internally connected
With cable	Variable
Protection class	I (if protective earth is connected by customer to the housing's connection point)
Conformity with standards	EN 60335-1; CE

Product drawing

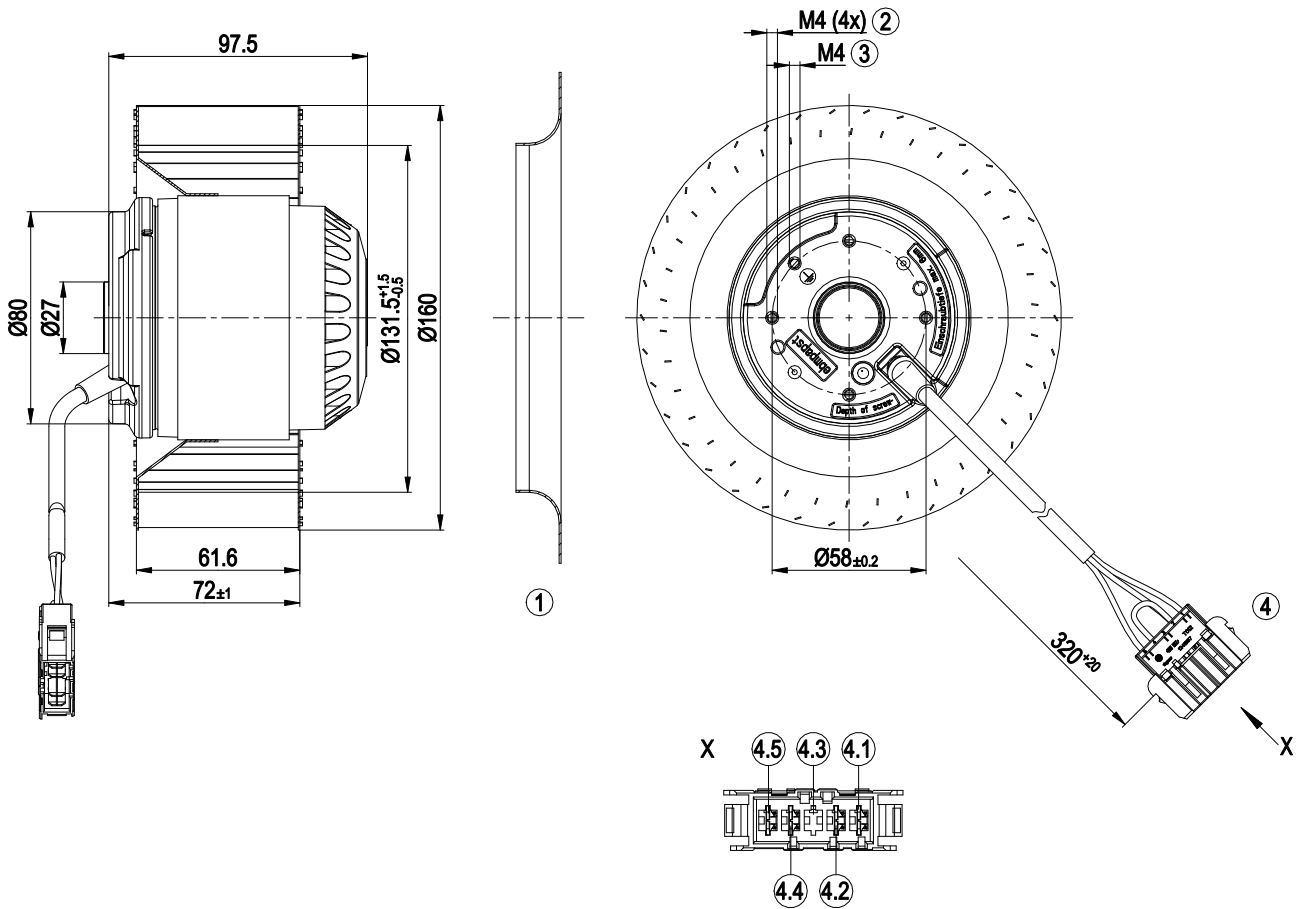

1	Accessory part: inlet ring 09588-2-4013 not included in scope of delivery
2	Max. clearance for screw 6 mm
3	Max. clearance for screw 6 mm
4	Cable silicone 3x 0.5 mm ² , tyco 5-pole connector housing 9-1241857-5, 4x flat plug 6.3x0.8
4.1	L (blue)
4.2	N (black + gray)
4.3	not used
4.4	Capacitor (gray)
4.5	Capacitor (brown)



Accessory part

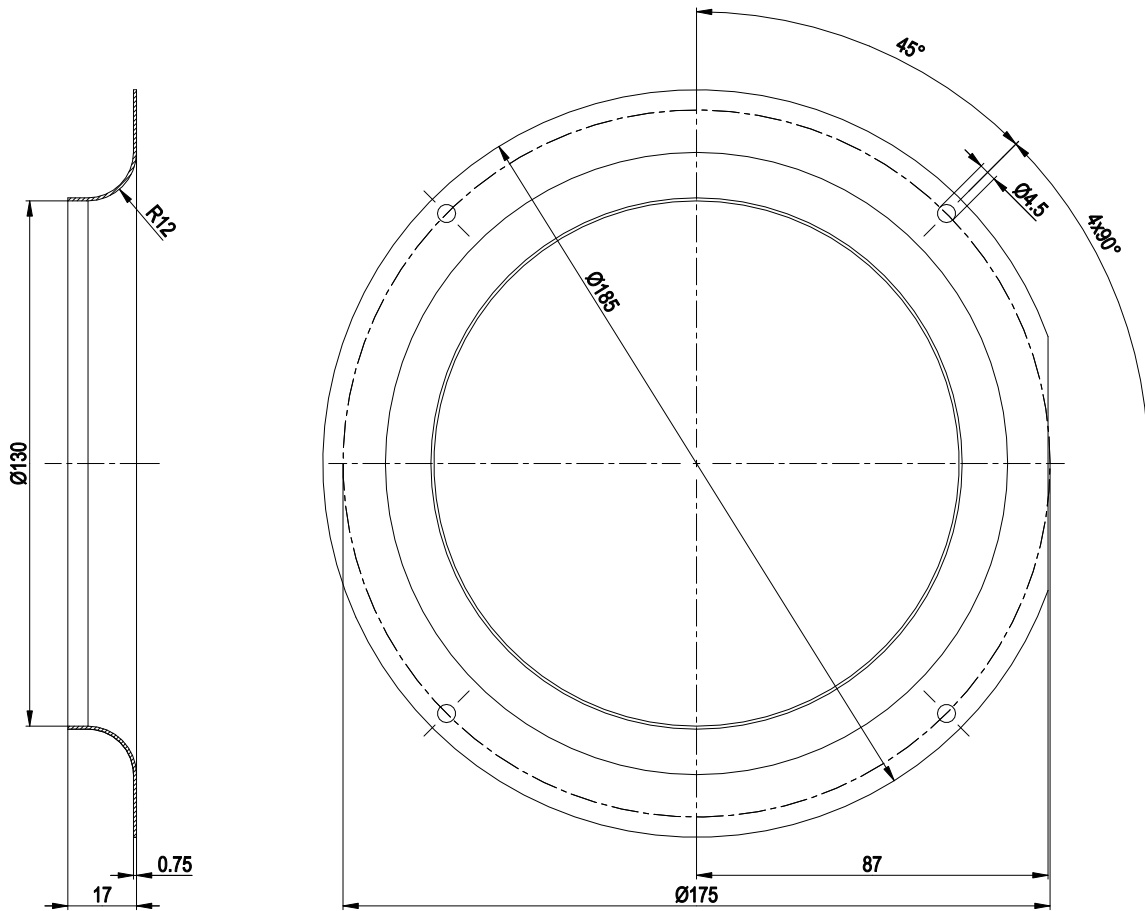

Accessory part: inlet ring 09588-2-4013 not included in scope of delivery

Connection diagram

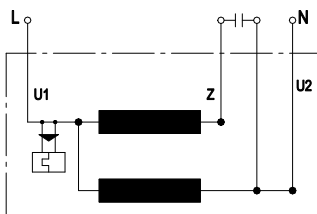

U1	blue	Z	brown	U2	black
----	------	---	-------	----	-------



Curves: Air performance 50 Hz

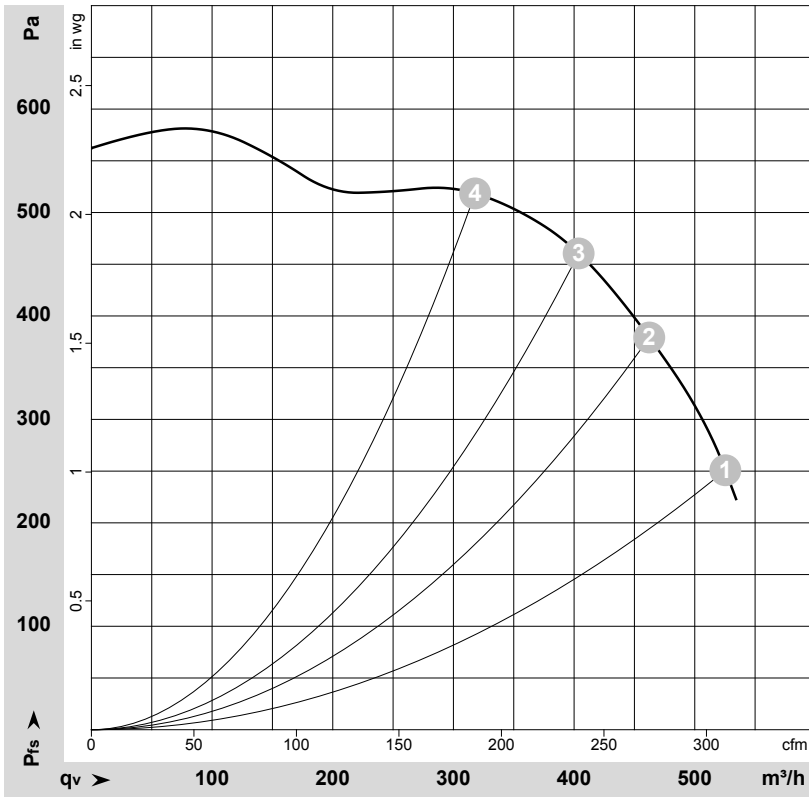

$\rho = 1.15 \text{ kg/m}^3 \pm 2 \%$

Measurement: LU-140176-1

Air performance measured according to ISO 5801 installation category A. For detailed information on the measurement setup, contact ebmpapst. Intake sound level: Sound power level according to ISO 13347 / sound pressure level measured at 1 m distance from fan axis. The values given are valid under the specified measuring conditions and may vary due to conditions of installation. For deviations from the standard configuration, the parameters have to be checked on the installed unit.

Measured values

	U	f	n	P _e	I	q _v	P _{fs}	q _v	P _{fs}
	V	Hz	min ⁻¹	W	A	m ³ /h	Pa	cfm	inH ₂ O
1	230	50	2400	230	0.99	525	250	310	1.00
2	230	50	2545	199	0.87	460	380	270	1.53
3	230	50	2630	173	0.76	405	460	240	1.85
4	230	50	2720	148	0.65	320	520	185	2.09

U = Power supply · f = Frequency · n = Speed (rpm) · P_e = Power consumption · I = Current draw · q_v = Air flow · P_{fs} = Pressure increase

