

R2E160-AY50-28 ebmpapst Datasheet

sales@fansco.com

www.fansco.com

Limited partnership · Headquarters Mulfingen
County court Stuttgart · HRA 590344General partner Elektrobau Mulfingen GmbH · Headquarters Mulfingen
County court Stuttgart · HRB 590142

Nominal data

Type	R2E160-AY50-28			
Motor	M2E068-EC			
Phase		1~	1~	1~
Nominal voltage	VAC	230	230	230
Frequency	Hz	50	60	60
Type of data definition		ml	ml	ml
Valid for approval / standard		CE	CE	UL 2111
Speed (rpm)	min ⁻¹	2400	2700	2700
Power input	W	230	275	285
Current draw	A	0.99	1.2	1.25
Motor capacitor	µF	5	6	6
Capacitor voltage	VDB	400	400	400
Capacitor standard			S0 (CE)	S0 (CE)
Min. back pressure	Pa	250	405	405
Min. ambient temperature	°C	-25	-25	-25
Max. ambient temperature	°C	60	50	50
Starting current	A	1.7	1.6	1.6

ml = Max. load · me = Max. efficiency · fa = Running at free air · cs = Customer specs · cu = Customer unit
Subject to alterations

Data according to ErP directive

		Actual	Request 2015
01 Overall efficiency η_{es}	%	32.3	32.3
02 Measurement category		A	
03 Efficiency category		Static	
04 Efficiency grade N		44	44
05 Variable speed drive		No	

Data definition with optimum efficiency.
The ErP data is determined using a motor-impeller combination in a standardised measurement configuration.

09 Power input P_e	kW	0.14
09 Air flow q_v	m ³ /h	335
09 Pressure increase p_{fs}	Pa	498
10 Speed (rpm) n	min ⁻¹	2735
11 Specific ratio*		1.00

* Specific ratio = $1 + p_{fs} / 100\,000\text{ Pa}$

LU-159463



Technical features

Mass	2.7 kg
Size	160 mm
Surface of rotor	Uncoated
Material of impeller	Sheet steel, galvanised
Direction of rotation	Clockwise, seen on rotor
Type of protection	IP 44; Depending on installation and position as per EN 60034-5
Insulation class	"F"
Humidity (F)/environmental protection class (H)	H0 - dry environment
Max. permissible ambient motor temp. (transp./ storage)	+ 80 °C
Min. permissible ambient motor temp. (transp./storage)	- 40 °C
Mounting position	Shaft horizontal or rotor on bottom; rotor on top on request
Condensate discharge holes	Rotor-side
Operation mode	S1
Motor bearing	Ball bearing
Touch current acc. IEC 60990 (measuring network Fig. 4, TN system)	< 0.75 mA
Motor protection	Thermal overload protector (TOP) wired internally
Cable exit	Variable
Protection class	I (if protective earth is connected by customer)
Product conforming to standard	EN 60335-1; CE
Approval	UL 2111; CSA C22.2 No.77

Product drawing

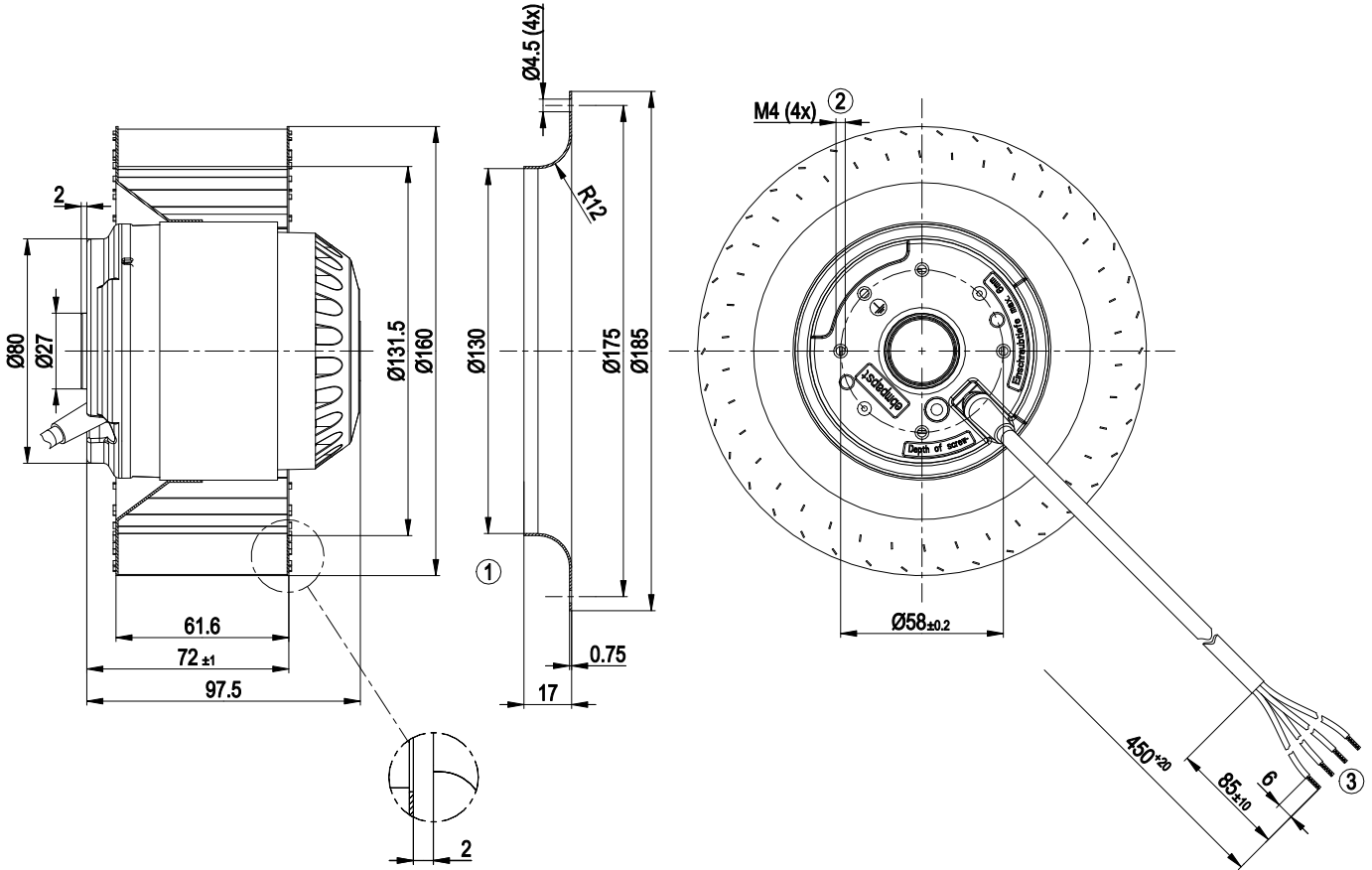

- | | |
|---|--|
| 1 | Accessory part: Inlet nozzle 09588-2-4013, not included in scope of delivery |
| 2 | Thread reach max. 6 mm |
| 3 | Connection line PFA AWG20 (green/yellow AWG18), 4x lead tips crimped |

Connection screen

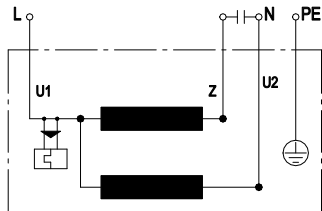

U1	blue	Z	brown	U2	black
PE	green/yellow				

Charts: Air flow 50 Hz

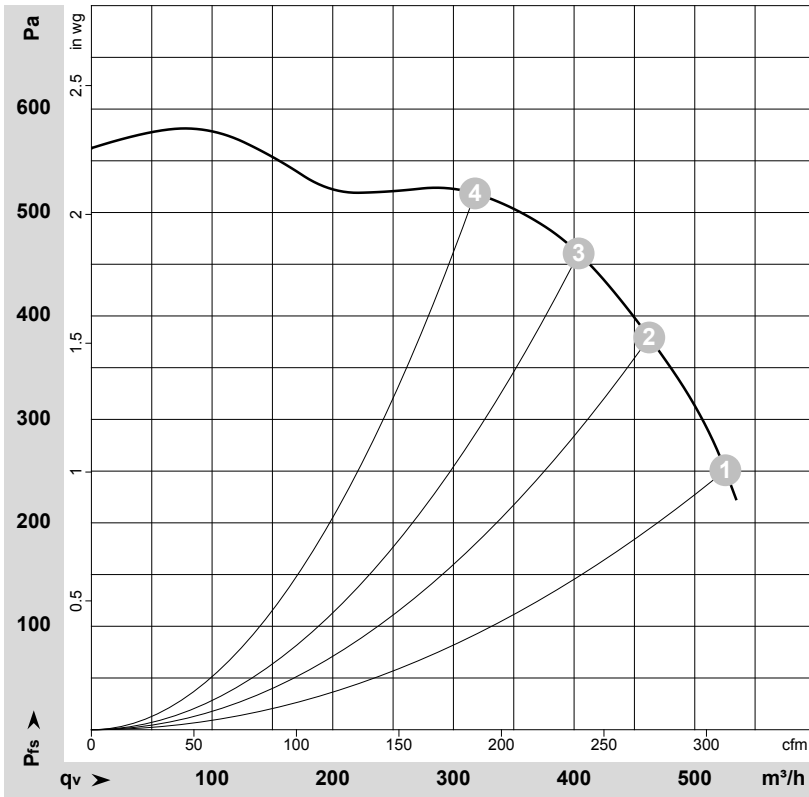

$\rho = 1.15 \text{ kg/m}^3 \pm 2 \%$

Measurement: LU-140176-1

Air performance measured as per ISO 5801 Installation category A. For detailed information on the measuring set-up, please contact ebmpapst. Suction-side noise levels: LwA measured as per ISO 13347 / LpA measured with 1m distance to fan axis. The values given are valid under the measuring conditions mentioned above and may vary according to the actual installation situation. With any deviation from the standard set-up, the specific values have to be checked and reviewed with the unit installed.

Measured values

	U	f	n	P _e	I	q _v	p _{fs}	q _v	p _{fs}
	V	Hz	min ⁻¹	W	A	m ³ /h	Pa	cfm	inH2O
1	230	50	2400	230	0.99	525	250	310	1.00
2	230	50	2545	199	0.87	460	380	270	1.53
3	230	50	2630	173	0.76	405	460	240	1.85
4	230	50	2720	148	0.65	320	520	185	2.09

U = Supply voltage · f = Frequency · n = Speed (rpm) · P_e = Power input · I = Current draw · q_v = Air flow · p_{fs} = Pressure increase

Charts: Air flow 60 Hz

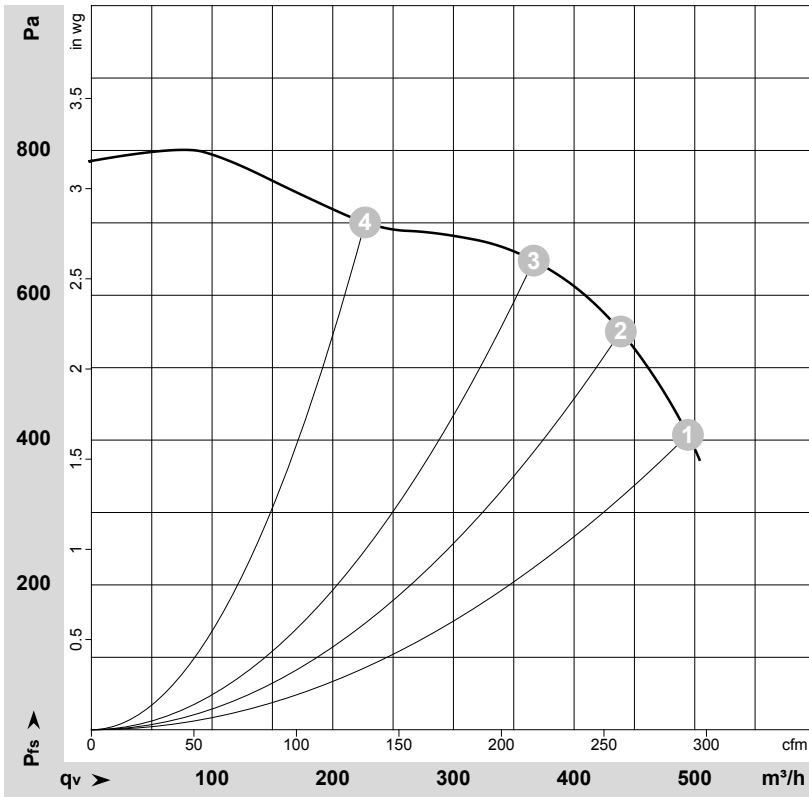

$\rho = 1.15 \text{ kg/m}^3 \pm 2 \%$

Measurement: LU-168444-1

Air performance measured as per ISO 5801 Installation category A. For detailed information on the measuring set-up, please contact ebmpapst. Suction-side noise levels: LwA measured as per ISO 13347 / LpA measured with 1m distance to fan axis. The values given are valid under the measuring conditions mentioned above and may vary according to the actual installation situation. With any deviation from the standard set-up, the specific values have to be checked and reviewed with the unit installed.

Measured values

	U	f	n	P _e	I	q _v	P _{fs}	q _v	P _{fs}
	V	Hz	min ⁻¹	W	A	m ³ /h	Pa	cfm	inH2O
1	230	60	2700	275	1.20	495	405	290	1.63
2	230	60	2910	249	1.10	440	550	260	2.21
3	230	60	3080	220	0.98	365	650	215	2.61
4	230	60	3270	181	0.83	225	700	135	2.81

U = Supply voltage · f = Frequency · n = Speed (rpm) · P_e = Power input · I = Current draw · q_v = Air flow · P_{fs} = Pressure increase

