

for solid-fuel heating systems



R2E150-AO91-01 ebmpapst Datasheet

sales@fansco.com

www.fansco.com

Limited partnership · Headquarters Muldingen
 Amtsgericht (court of registration) Stuttgart · HRA 590344

General partner Elektrobau Muldingen GmbH · Headquarters Muldingen
 Amtsgericht (court of registration) Stuttgart · HRB 590142

Nominal data

Type	R2E150-AO91-01	
Motor	M2E068-BF	
Phase		1~
Nominal voltage	VAC	230
Frequency	Hz	50
Method of obtaining data		fa
Valid for approval/standard		CE
Speed (rpm)	min ⁻¹	2400
Power consumption	W	32
Current draw	A	0.15
Capacitor	μF	1
Capacitor voltage	VDB	400
Capacitor standard		S0 (CE)
Min. back pressure	Pa	0
Min. back pressure	inH2O	0
Min. ambient temperature	°C	-25
Max. ambient temperature	°C	55
Starting current	A	0.2

ml = Max. load · me = Max. efficiency · fa = Free air · cs = Customer specification · ce = Customer equipment
 Subject to change



Technical description

Weight	1.7 kg
Fan size	150 mm
Rotor surface	Partly cast in aluminum
Impeller material	Sheet steel, stainless
Support plate material	Sheet steel, hot-dip galvanized
Number of blades	6
Motor suspension	Motor mounted on support plate for one-sided vibration damping
Direction of rotation	Clockwise, viewed toward rotor
Degree of protection	IP44; installation- and position-dependent
Insulation class	"F"
Moisture (F) / Environmental (H) protection class	H0 - dry environment
Max. permitted ambient temp. for motor (transport/storage)	+ 80 °C
Min. permitted ambient temp. for motor (transport/storage)	- 40 °C
Installation position	Any
Condensation drainage holes	None
Mode	S1
Motor bearing	Ball bearing
Technical features	- Speed monitoring Hall IC
Touch current according to IEC 60990 (measuring circuit Fig. 4, TN system)	< 0.75 mA
Motor protection	Thermal overload protector (TOP) internally connected
With cable	Variable
Protection class	I (with customer connection of protective earth)
Conformity with standards	EN 60335-1; CE

Product drawing

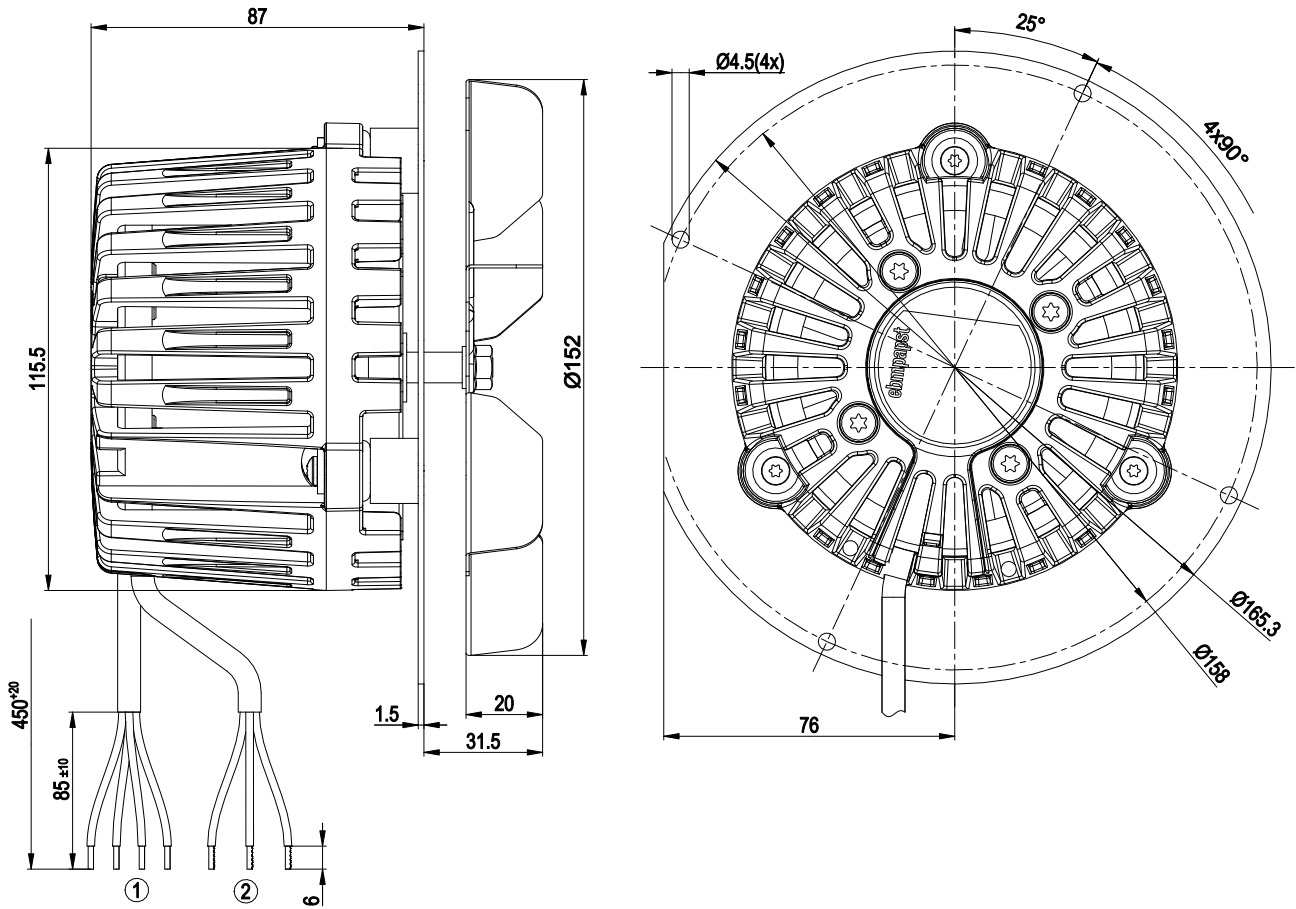

- | | |
|---|---|
| 1 | Cable PVC 4G 0.5 mm ² , 4x crimped splices |
| 2 | Cable Hall IC Raychem 3X AWG24, 3 x crimped splices |

Connection diagram

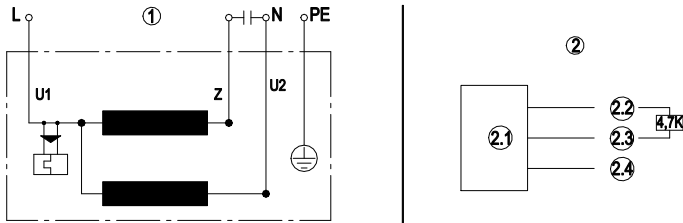

1 Fan connection diagram

U1 blue

Z brown

U2 black

PE green/yellow

2 Hall IC circuit

2.1 Hall IC

2.2 red (+5 V)

2.3 white (out)

2.4 black (0 V)

Curves: Air performance 50 Hz

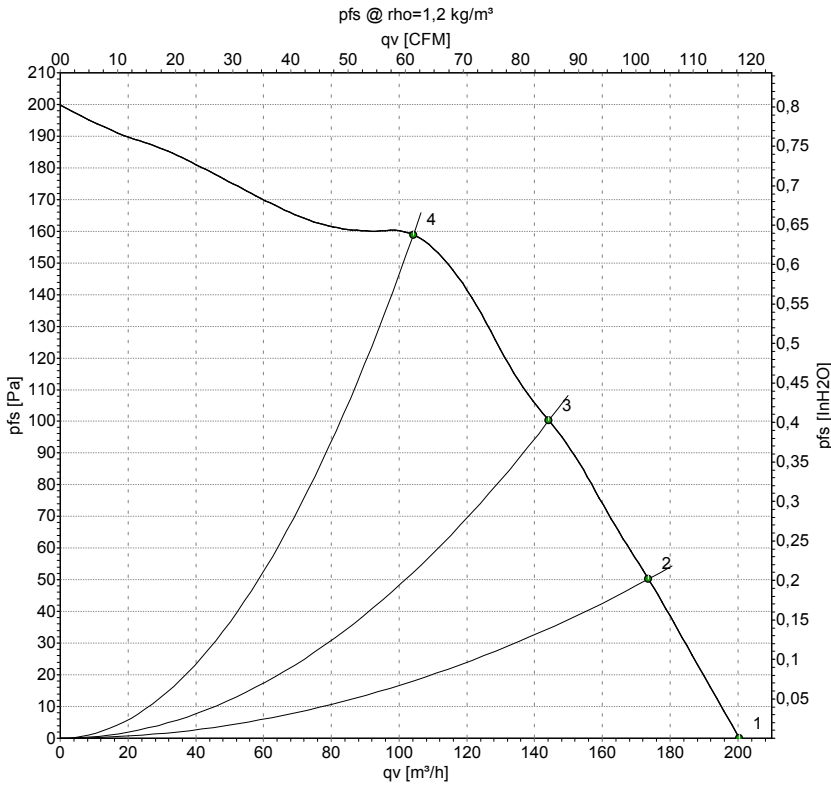

Measurement: LU-151913-1

Air performance measured according to ISO 5801 installation category A. For detailed information on the measurement setup, contact ebmpapst. Intake sound level: Sound power level according to ISO 13347 / sound pressure level measured at 1 m distance from fan axis. The values given are valid under the specified measuring conditions and may vary due to conditions of installation. For deviations from the standard configuration, the parameters have to be checked on the installed unit.

Measured values

	U	f	n	P _e	I	q _v	p _{fs}	q _v	p _{fs}
	V	Hz	min ⁻¹	W	A	m ³ /h	Pa	cfm	inH2O
1	230	50	2400	32	0.15	200	0	120	0.00
2	230	50	2410	31	0.14	175	50	100	0.20
3	230	50	2435	31	0.14	145	100	85	0.40
4	230	50	2485	30	0.13	105	160	60	0.64

U = Power supply · f = Frequency · n = Speed (rpm) · P_e = Power consumption · I = Current draw · q_v = Air flow · p_{fs} = Pressure increase

