

AC circulation blower for hot air

forward-curved

R2E150-AN91-59 ebmpapst Datasheet
 sales@fansco.com
 www.fansco.com

Limited partnership · Headquarters Muldingen
 Amtsgericht (court of registration) Stuttgart · HRA 590344
 General partner Elektrobau Muldingen GmbH · Headquarters Muldingen
 Amtsgericht (court of registration) Stuttgart · HRB 590142

Nominal data

Type	R2E150-AN91-59	
Motor	M2E068-BF	
Phase		1~
Nominal voltage	VAC	230
Frequency	Hz	50
Method of obtaining data		fa
Valid for approval/standard		CE
Speed (rpm)	min ⁻¹	2400
Power consumption	W	32
Current draw	A	0.14
Capacitor	µF	1
Capacitor voltage	VDB	400
Min. back pressure	Pa	0
Min. back pressure	inH ₂ O	0
Min. ambient temperature	°C	-25
Max. ambient temperature	°C	100
Starting current	A	0.2

ml = Max. load · me = Max. efficiency · fa = Free air · cs = Customer specification · ce = Customer equipment
 Subject to change



Technical description

Weight	1.7 kg
Fan size	150 mm
Rotor surface	Unpainted
Impeller material	Sheet steel, rust-resistant
Number of blades	6
Direction of rotation	Counterclockwise, viewed toward rotor
Degree of protection	IP44; installation- and position-dependent
Insulation class	"F"
Moisture (F) / Environmental (H) protection class	H0 - dry environment
Max. permitted ambient temp. for motor (transport/storage)	+ 80 °C
Min. permitted ambient temp. for motor (transport/storage)	- 40 °C
Installation position	Any
Condensation drainage holes	None
Mode	S1
Motor bearing	Ball bearing
Touch current according to IEC 60990 (measuring circuit Fig. 4, TN system)	< 0.75 mA
Motor protection	Thermal overload protector (TOP) internally connected
With cable	Variable
Protection class	I (with customer connection of protective earth)
Conformity with standards	EN 60034-1; EN 60204-1; CE



Product drawing

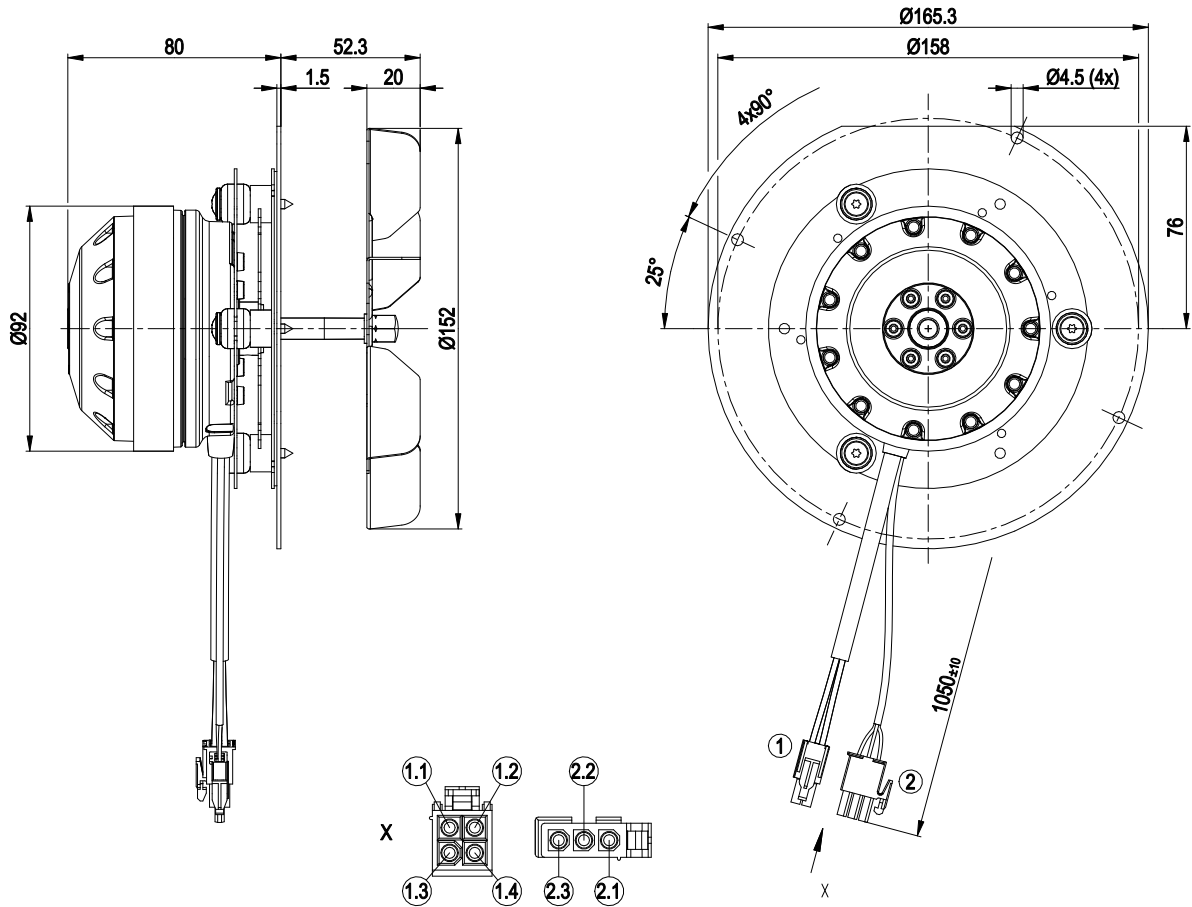

1	Cable silicone 4G 0.5 mm ² , 1x AMP Mini-Universal Mate-N-Lok connector housing 172167-1
1.1	black
1.2	brown
1.3	green/yellow
1.4	blue
2	Cable PFA AWG18, 1x AMP Mini-Universal Mate-N-Lok connector housing 172166-1
2.1	white
2.2	red
2.3	black



Connection diagram

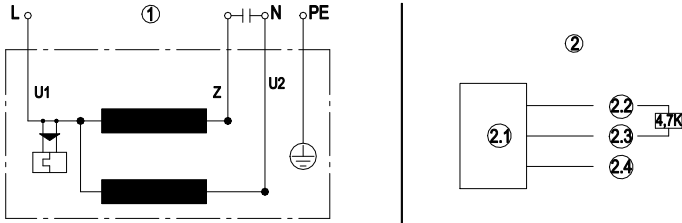

1	Fan connection diagram
U1	blue
Z	brown
U2	black
PE	green/yellow
2	Hall IC circuit
2.1	Hall IC
2.2	red (+5 V)
2.3	white (out)
2.4	black (0 V)



Curves: Air performance 50 Hz

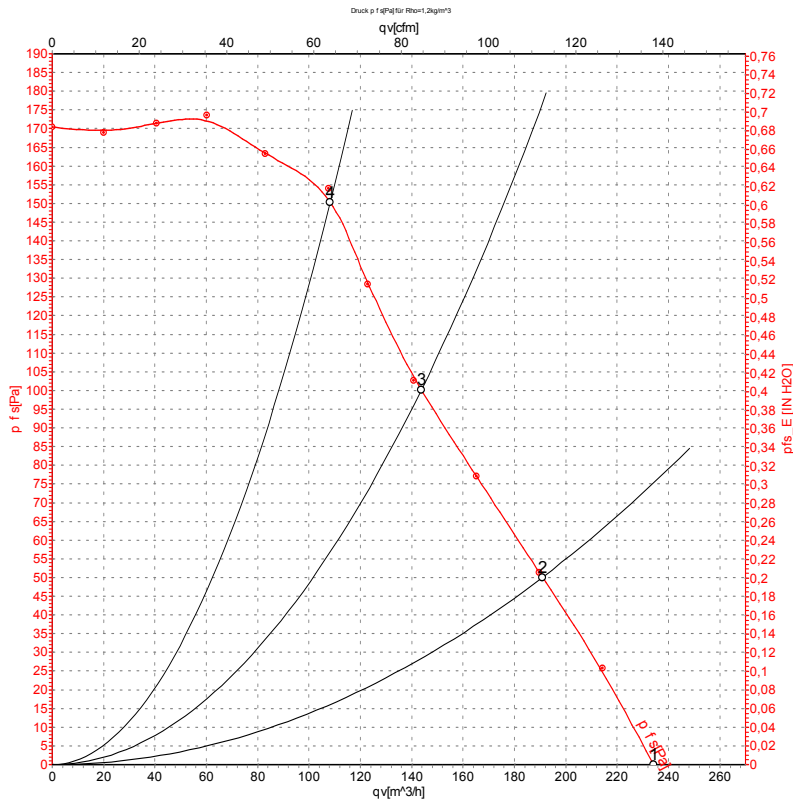

Measurement: LU-75643-1

Air performance measured according to ISO 5801 installation category A. For detailed information on the measurement setup, contact ebm-papst. Intake sound level: Sound power level according to ISO 13347 / sound pressure level measured at 1 m distance from fan axis. The values given are valid under the specified measuring conditions and may vary due to conditions of installation. For deviations from the standard configuration, the parameters have to be checked on the installed unit.

Measured values

	U	f	n	P _e	I	q _v	P _{fs}	q _v	P _{fs}
	V	Hz	min ⁻¹	W	A	m ³ /h	Pa	cfm	inH ₂ O
1	230	50	2400	32	0.14	235	0	140	0.00
2	230	50	2375	32	0.14	190	50	110	0.20
3	230	50	2400	31	0.13	145	100	85	0.40
4	230	50	2500	29	0.13	110	150	65	0.60

U = Power supply · f = Frequency · n = Speed (rpm) · P_e = Power consumption · I = Current draw · q_v = Air flow · P_{fs} = Pressure increase

