

for solid-fuel heating systems

R2E150-AN91-51 ebmpapst Datasheet

sales@fansco.com

www.fansco.com

## Nominal data

Type	R2E150-AN91-51	
Motor	M2E068-BF	
Phase		1~
Nominal voltage	VAC	230
Frequency	Hz	50
Method of obtaining data		fa
Valid for approval/standard		CE
Speed (rpm)	min <sup>-1</sup>	2400
Power consumption	W	32
Current draw	A	0.14
Capacitor	μF	1
Capacitor voltage	VDB	400
Capacitor standard		S0 (CE)
Min. back pressure	Pa	0
Min. back pressure	inH2O	0
Min. ambient temperature	°C	-25
Max. ambient temperature	°C	100
Starting current	A	0.2

ml = Max. load · me = Max. efficiency · fa = Free air · cs = Customer specification · ce = Customer equipment  
Subject to change



### Technical description

Weight	2.3 kg
Fan size	150 mm
Rotor surface	Unpainted
Impeller material	Sheet steel, rust-resistant
Number of blades	6
Direction of rotation	Counterclockwise, viewed toward rotor
Degree of protection	IP44; installation- and position-dependent
Insulation class	"F"
Moisture (F) / Environmental (H) protection class	H0 - dry environment
Max. permitted ambient temp. for motor (transport/storage)	+ 80 °C
Min. permitted ambient temp. for motor (transport/storage)	- 40 °C
Installation position	Any
Condensation drainage holes	None
Mode	S1
Motor bearing	Ball bearing
Touch current according to IEC 60990 (measuring circuit Fig. 4, TN system)	< 0.75 mA
Motor protection	Thermal overload protector (TOP) internally connected
With cable	Variable
Protection class	I (with customer connection of protective earth)
Motor capacitor according to EN 60252-1 in safety protection class	S2
Conformity with standards	EN 60034-1; EN 60204-1; CE

Product drawing

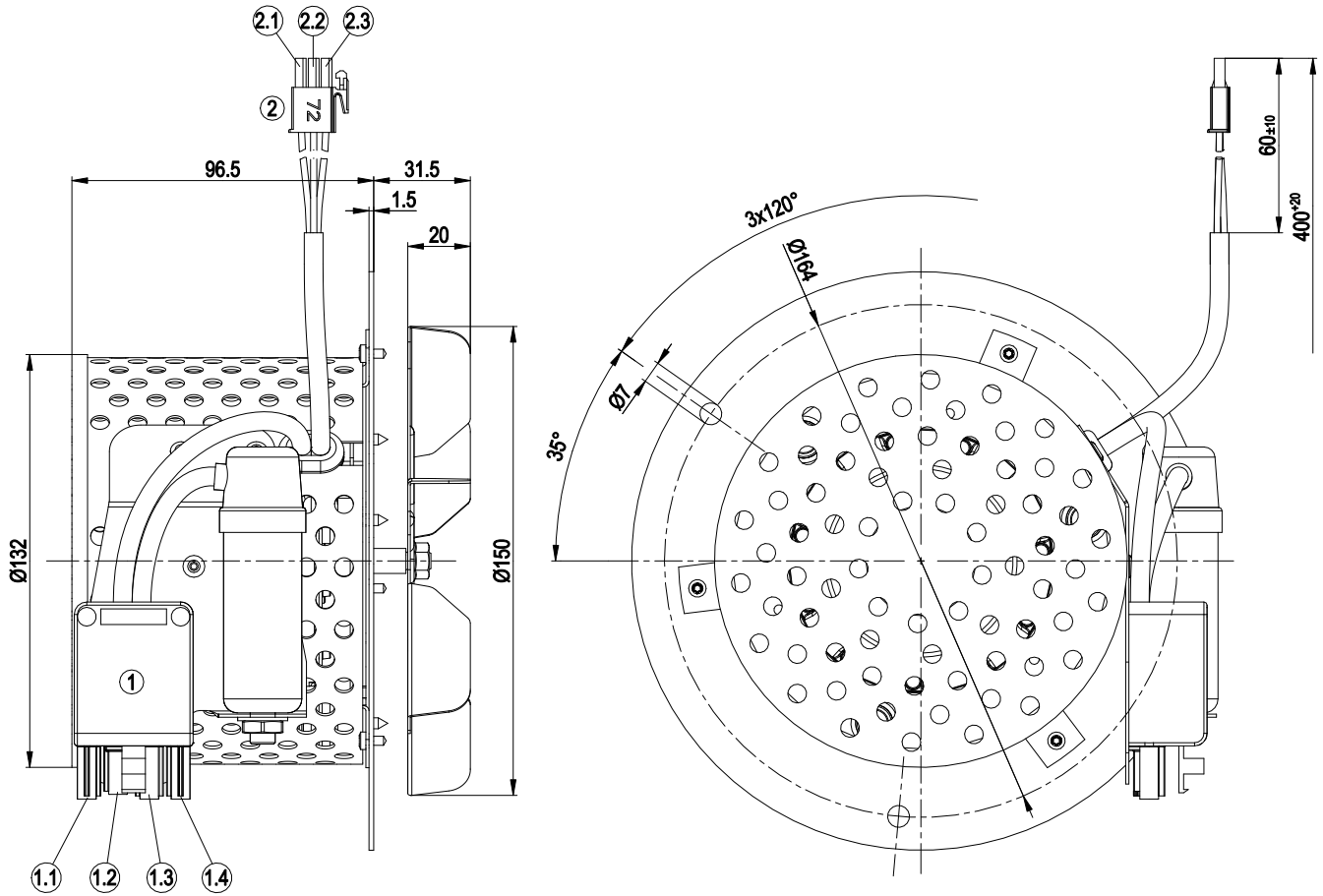

1	4-pole connector housing Wieland 93.932.4857.0
1.1	black + capacitor
1.2	green/yellow
1.3	blue
1.4	brown + capacitor
2	Cable Raychem Spec. 44, AWG24, 3-pole connector housing tyco 172166-1, 3x socket contact tyco 170361-1
2.1	red
2.2	white
2.3	black



## Connection diagram

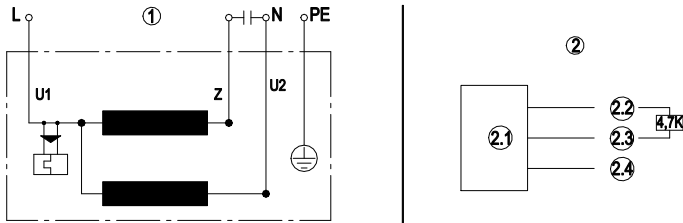

1	Fan connection diagram
---	------------------------

U1	blue
----	------

Z	brown
---	-------

U2	black
----	-------

PE	green/yellow
----	--------------

2	Hall IC circuit
---	-----------------

2.1	Hall IC
-----	---------

2.2	red (+5 V)
-----	------------

2.3	white (out)
-----	-------------

2.4	black (0 V)
-----	-------------

## Curves: Air performance 50 Hz

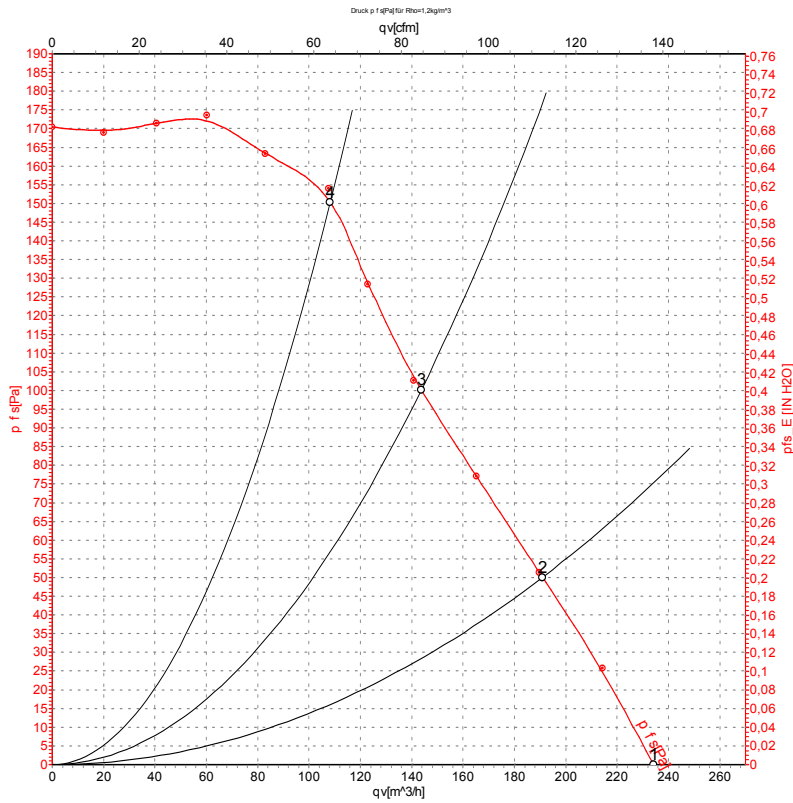

Measurement: LU-75643-1

Air performance measured according to ISO 5801 installation category A. For detailed information on the measurement setup, contact ebm-papst. Intake sound level: Sound power level according to ISO 13347 / sound pressure level measured at 1 m distance from fan axis. The values given are valid under the specified measuring conditions and may vary due to conditions of installation. For deviations from the standard configuration, the parameters have to be checked on the installed unit.

## Measured values

	U	f	n	P <sub>e</sub>	I	q <sub>v</sub>	p <sub>is</sub>	q <sub>v</sub>	p <sub>is</sub>
	V	Hz	min <sup>-1</sup>	W	A	m <sup>3</sup> /h	Pa	cfm	inH <sub>2</sub> O
1	230	50	2400	32	0.14	235	0	140	0.00
2	230	50	2375	32	0.14	190	50	110	0.20
3	230	50	2400	31	0.13	145	100	85	0.40
4	230	50	2500	29	0.13	110	150	65	0.60

U = Power supply · f = Frequency · n = Speed (rpm) · P<sub>e</sub> = Power consumption · I = Current draw · q<sub>v</sub> = Air flow · p<sub>is</sub> = Pressure increase

