

for solid-fuel heating systems

R2E150-AN91-05 ebmpapst Datasheet

sales@fansco.com

www.fansco.com

Limited partnership · Headquarters Mulfingen

Amtsgericht (court of registration) Stuttgart · HRA 590344

General partner Elektrobau Mulfingen GmbH · Headquarters Mulfingen

Amtsgericht (court of registration) Stuttgart · HRB 590142

## Nominal data

Type	R2E150-AN91-05	
Motor	M2E068-BF	
Phase		1~
Nominal voltage	VAC	230
Frequency	Hz	50
Method of obtaining data		fa
Valid for approval/standard		CE
Speed (rpm)	min <sup>-1</sup>	2400
Power consumption	W	32
Current draw	A	0.14
Capacitor	µF	1
Capacitor voltage	VDB	400
Min. back pressure	Pa	0
Min. back pressure	inH <sub>2</sub> O	0
Min. ambient temperature	°C	-25
Max. ambient temperature	°C	100

ml = Max. load · me = Max. efficiency · fa = Free air · cs = Customer specification · ce = Customer equipment  
Subject to change



### Technical description

<b>Weight</b>	2.0 kg
<b>Fan size</b>	150 mm
<b>Rotor surface</b>	Unpainted
<b>Impeller material</b>	Sheet steel, stainless
<b>Housing material</b>	Steel, phosphated and coated with black plastic
<b>Support plate material</b>	Sheet steel, hot-dip galvanized
<b>Number of blades</b>	6
<b>Direction of rotation</b>	Counterclockwise, viewed toward rotor
<b>Degree of protection</b>	IP44; installation- and position-dependent
<b>Insulation class</b>	"F"
<b>Moisture (F) / Environmental (H) protection class</b>	H0 - dry environment
<b>Max. permitted ambient temp. for motor (transport/storage)</b>	+ 80 °C
<b>Min. permitted ambient temp. for motor (transport/storage)</b>	- 40 °C
<b>Installation position</b>	Any
<b>Condensation drainage holes</b>	None
<b>Mode</b>	S1
<b>Motor bearing</b>	Ball bearing
<b>Touch current according to IEC 60990 (measuring circuit Fig. 4, TN system)</b>	< 0.75 mA
<b>Motor protection</b>	Thermal overload protector (TOP) internally connected
<b>With cable</b>	Variable
<b>Protection class</b>	I (with customer connection of protective earth)
<b>Conformity with standards</b>	EN 60335-1; CE
<b>Approval</b>	EAC

Product drawing

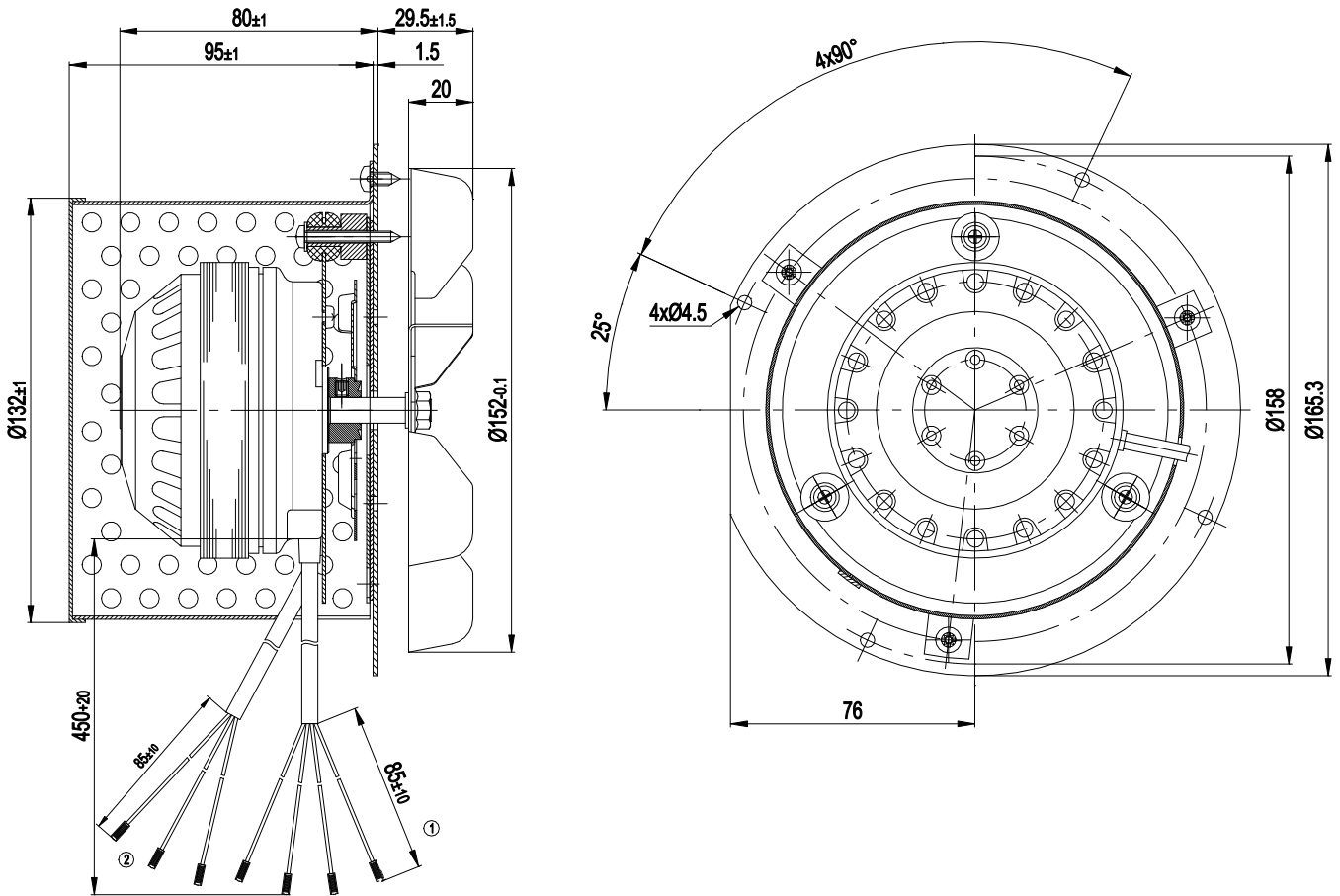

- 1 Cable silicone, 4x crimped splices
- 2 Cable, 3x crimped splices



## Connection diagram

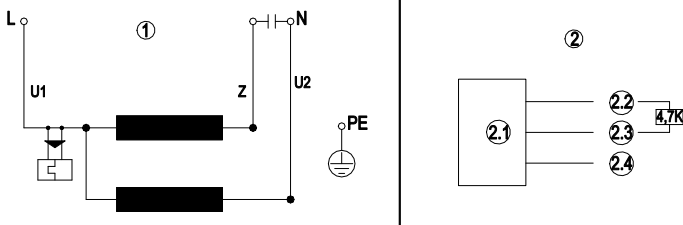

1	Fan connection diagram
U1	blue
Z	brown
U2	black
PE	green/yellow
2	Hall IC circuit
2.1	Hall IC
2.2	red (+5 V)
2.3	white (out)
2.4	black (0 V)



## Curves: Air performance 50 Hz

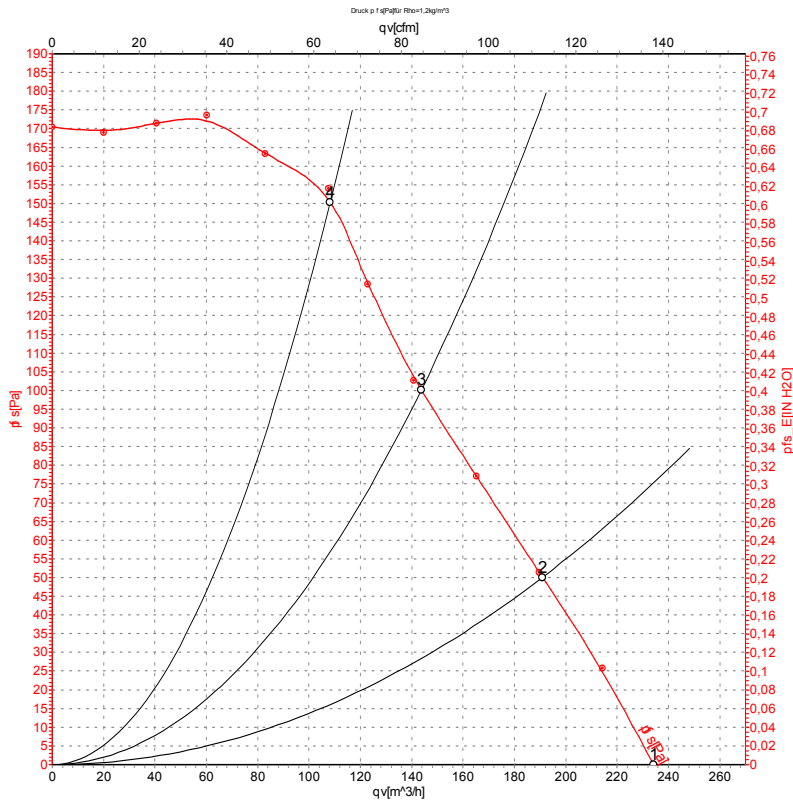

Measurement: LU-75643-1

Air performance measured according to ISO 5801 installation category A. For detailed information on the measurement setup, contact ebm-papst. Intake sound level: Sound power level according to ISO 13347 / sound pressure level measured at 1 m distance from fan axis. The values given are valid under the specified measuring conditions and may vary due to conditions of installation. For deviations from the standard configuration, the parameters have to be checked on the installed unit.

## Measured values

	U	f	n	P <sub>e</sub>	I	qv	p <sub>fs</sub>	qv	p <sub>fs</sub>
	V	Hz	min <sup>-1</sup>	W	A	m <sup>3</sup> /h	Pa	CFM	inH <sub>2</sub> O
1	230	50	2400	32	0.14	235	0	140	0.00
2	230	50	2375	32	0.14	190	50	110	0.20
3	230	50	2400	31	0.13	145	100	85	0.40
4	230	50	2500	29	0.13	110	150	65	0.60

U = Power supply · f = Frequency · n = Speed (rpm) · P<sub>e</sub> = Power consumption · I = Current draw · qv = Air flow · p<sub>fs</sub> = Pressure increase

