

for solid fuel heating systems

R2E150-AN89-16 ebmpapst Datasheet

sales@fansco.com

www.fansco.com

Limited partnership · Headquarters Muldingen
 County court Stuttgart · HRA 590344

General partner Elektrobau Muldingen GmbH · Headquarters Muldingen
 County court Stuttgart · HRB 590142

Nominal data

Type	R2E150-AN89-16	
Motor	M2E068-BF	
Phase		1~
Nominal voltage	VAC	115
Frequency	Hz	60
Type of data definition		fa
Valid for approval / standard		CE
Speed	min ⁻¹	2550
Power input	W	33
Current draw	A	0.3
Motor capacitor	µF	3
Capacitor voltage	VDB	220
Min. back pressure	Pa	0
Max. ambient temperature	°C	100

ml = max. load · me = max. efficiency · fa = running at free air · cs = customer specs · cu = customer unit
 Subject to alterations



Technical features

Mass	1.7 kg
Size	150 mm
Surface of rotor	Uncoated
Material of impeller	Sheet steel, galvanised
Number of blades	6
Direction of rotation	Counter-clockwise, seen on rotor
Type of protection	IP 44; Depending on installation and position
Insulation class	"F"
Humidity class	F0
Max. permissible ambient motor temp. (transp./ storage)	+ 80 °C
Min. permissible ambient motor temp. (transp./storage)	- 40 °C
Mounting position	Any
Condensate discharge holes	None
Operation mode	S1
Motor bearing	Ball bearing
Touch current acc. IEC 60990 (measuring network Fig. 4, TN system)	< 0.75 mA
Motor protection	Thermal overload protector (TOP) wired internally
Cable exit	Variable
Protection class	I (if protective earth is connected by customer)
Product conforming to standard	EN 60335-1; CE
Approval	UL 1004-1; CSA C22.2 Nr.100

Product drawing

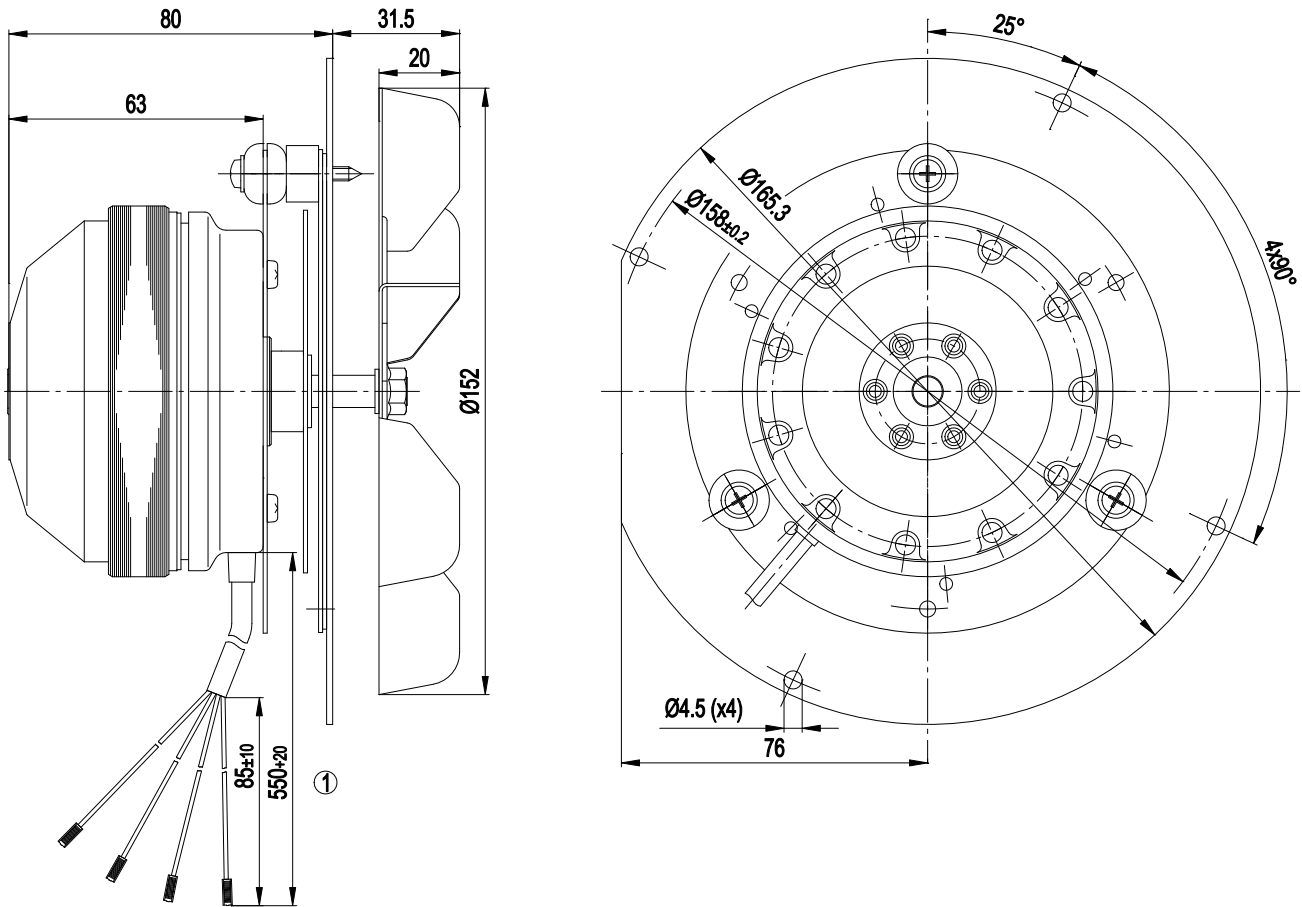

1 Connection line PFA, 4x brass lead tips crimped

Connection screen

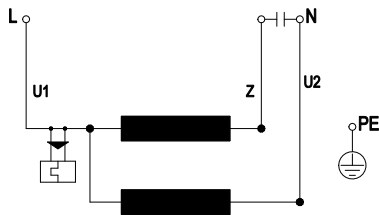

U1	blue	Z	brown	U2	black
PE	green/yellow				

Charts: Air flow 60 Hz

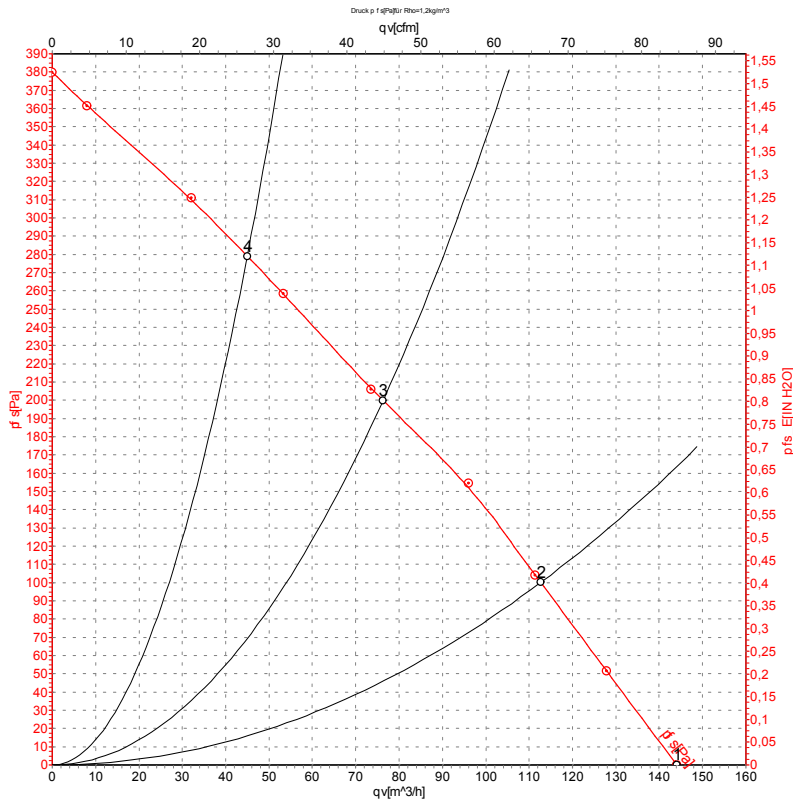

Measurement: LU-13862

Air performance measured as per ISO 5801 Installation category A. For detailed information on the measuring set-up, please contact ebmpapst. Suction-side noise levels: L_{wA} measured as per ISO 13347 / L_{pA} measured with 1m distance to fan axis. The values given are valid under the measuring conditions mentioned above and may vary according to the actual installation situation. With any deviation from the standard set-up, the specific values have to be checked and reviewed with the unit installed.

Measured values

	U	f	n	P _e	I	qv	P _{fs}
	V	Hz	min ⁻¹	W	A	m ³ /h	Pa
1	115	60	2550	33	0.30	145	0
2	115	60	2635	32	0.28	115	100
3	115	60	2755	31	0.27	75	200
4	115	60	2865	30	0.26	45	280

U = Supply voltage · f = Frequency · n = Speed · P_e = Power input · I = Current draw · qv = Air flow · P_{fs} = Pressure increase

