

for solid-fuel heating systems

R2E150-AN89-14 ebmpapst Datasheet

sales@fansco.com

www.fansco.com

Limited partnership · Headquarters Mulfingen

Amtsgericht (court of registration) Stuttgart · HRA 590344

General partner Elektrobau Mulfingen GmbH · Headquarters Mulfingen

Amtsgericht (court of registration) Stuttgart · HRB 590142

## Nominal data

Type	R2E150-AN89-14		
Motor	M2E068-BF		
Phase		1~	1~
Nominal voltage	VAC	115	115
Frequency	Hz	60	60
Method of obtaining data		fa	fa
Valid for approval/standard		CE	UL 2111
Speed (rpm)	min <sup>-1</sup>	2550	-
Power consumption	W	33	40
Current draw	A	0.3	
Capacitor	µF	3	3
Capacitor voltage	VDB	220	220
Capacitor standard			UL
Min. back pressure	Pa	0	0
Min. back pressure	inH2O	0	0
Min. ambient temperature	°C	-25	-25
Max. ambient temperature	°C	80	80

ml = Max. load · me = Max. efficiency · fa = Free air · cs = Customer specification · ce = Customer equipment  
Subject to change



### Technical description

Weight	1.3 kg
Fan size	150 mm
Rotor surface	Unpainted
Impeller material	Sheet steel, stainless
Number of blades	6
Direction of rotation	Counterclockwise, viewed toward rotor
Degree of protection	IP44; installation- and position-dependent
Insulation class	"B"
Moisture (F) / Environmental (H) protection class	H0 - dry environment
Max. permitted ambient temp. for motor (transport/storage)	+ 80 °C
Min. permitted ambient temp. for motor (transport/storage)	- 40 °C
Installation position	Any
Condensation drainage holes	None
Mode	S1
Motor bearing	Ball bearing
Touch current according to IEC 60990 (measuring circuit Fig. 4, TN system)	< 0.75 mA
Motor protection	Thermal overload protector (TOP) internally connected
With cable	Variable
Protection class	I (with customer connection of protective earth)
Conformity with standards	EN 60335-1; CE
Approval	UL 2111; CSA C22.2 No. 77

## Product drawing

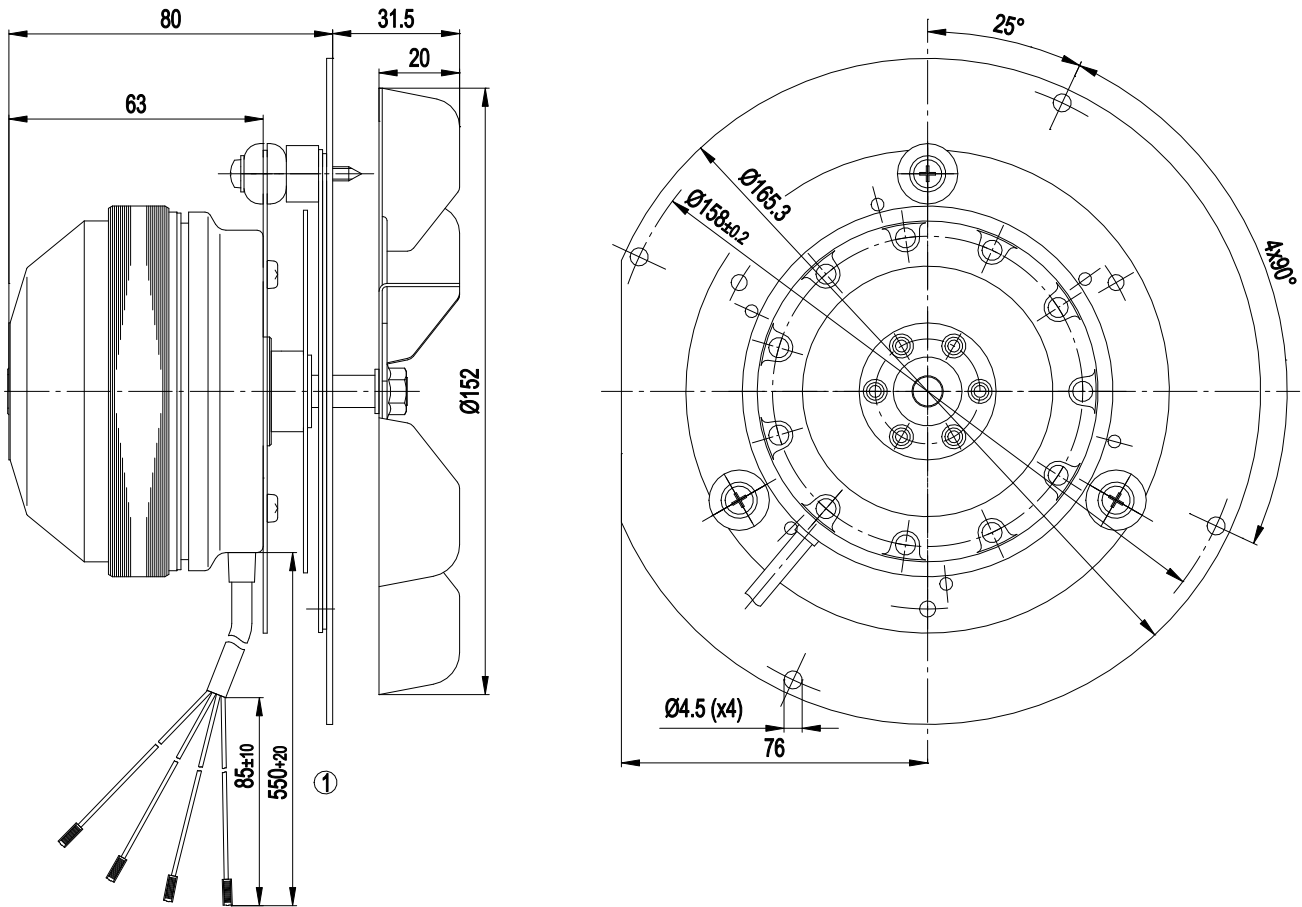

1 Cable PVC 4G AWG20, 4x crimped splices

## Connection diagram

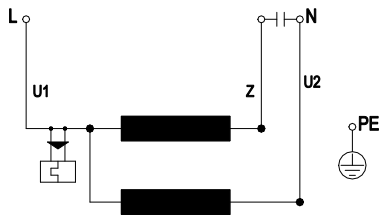

U1	blue	Z	brown	U2	black
PE	green/yellow				



## Curves: Air performance 60 Hz

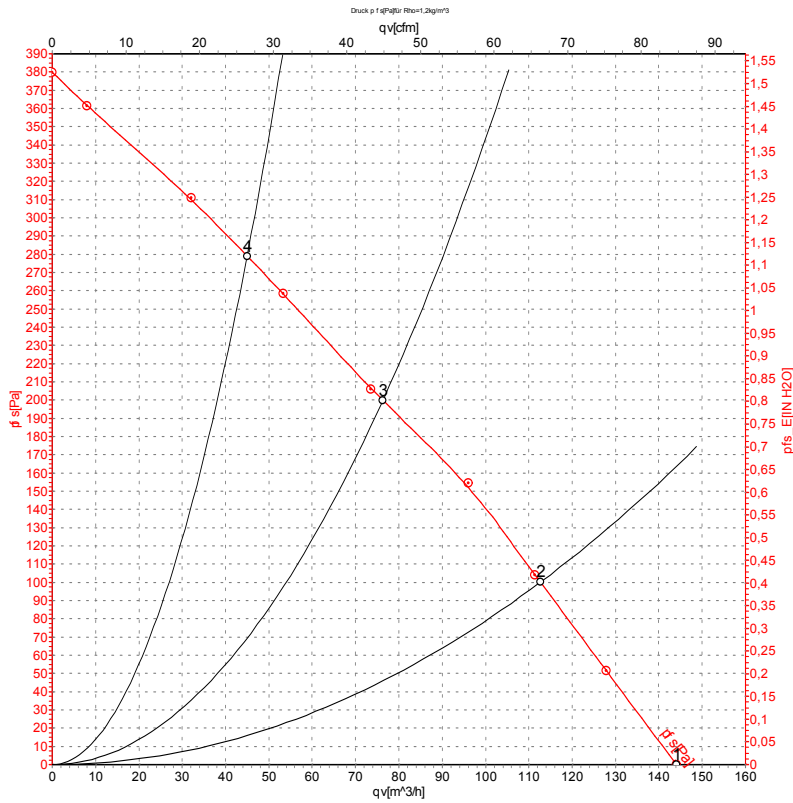

Measurement: LU-13862-1

Air performance measured according to ISO 5801 installation category A. For detailed information on the measurement setup, contact ebmpapst. Intake sound level: Sound power level according to ISO 13347 / sound pressure level measured at 1 m distance from fan axis. The values given are valid under the specified measuring conditions and may vary due to conditions of installation. For deviations from the standard configuration, the parameters have to be checked on the installed unit.

## Measured values

	U	f	n	P <sub>e</sub>	I	q <sub>v</sub>	p <sub>fs</sub>	q <sub>v</sub>	p <sub>fs</sub>
	V	Hz	min <sup>-1</sup>	W	A	m <sup>3</sup> /h	Pa	cfm	inH <sub>2</sub> O
1	115	60	2550	33	0.30	145	0	85	0.00
2	115	60	2635	32	0.28	115	100	65	0.40
3	115	60	2755	31	0.27	75	200	45	0.80
4	115	60	2865	30	0.26	45	280	25	1.12

U = Power supply · f = Frequency · n = Speed (rpm) · P<sub>e</sub> = Power consumption · I = Current draw · q<sub>v</sub> = Air flow · p<sub>fs</sub> = Pressure increase

