

R2E140-BN16-18 ebmpapst Datasheet FansCo

sales@fansco.com

www.fansco.com

Nominal data

Type	R2E140-BN16-18	
Motor	M2E068-CA	
Phase		1~
Nominal voltage	VAC	230
Frequency	Hz	50
Method of obtaining data		fa
Valid for approval/standard		CE
Speed (rpm)	min ⁻¹	1700
Power consumption	W	130
Current draw	A	0.57
Capacitor	μF	3
Capacitor voltage	VDB	450
Min. back pressure	Pa	0
Min. back pressure	in. wg	0
Min. ambient temperature	°C	-25
Max. ambient temperature	°C	40

ml = Max. load · me = Max. efficiency · fa = Free air · cs = Customer specification · ce = Customer equipment
Subject to change



Technical description

Weight	1.4 kg
Size	140 mm
Motor size	68
Rotor surface	Painted black
Impeller material	Sheet steel, galvanized
Direction of rotation	Clockwise, viewed toward rotor
Degree of protection	IP44; installation- and position-dependent as per EN 60034-5
Insulation class	"B"
Moisture (F) / Environmental (H) protection class	H1
Max. permitted ambient temp. for motor (transport/storage)	+ 80 °C
Min. permitted ambient temp. for motor (transport/storage)	- 40 °C
Installation position	Shaft horizontal or rotor on bottom; rotor on top on request
Condensation drainage holes	On rotor side
Mode	S1
Motor mounting	Ball bearing
Touch current according to IEC 60990 (measuring circuit Fig. 4, TN system)	< 0.75 mA
Motor protection	Temperature limiter manual reset
With cable	Variable
Protection class	I (with customer connection of protective earth)
Conformity with standards	EN 60335-1; CE

Product drawing

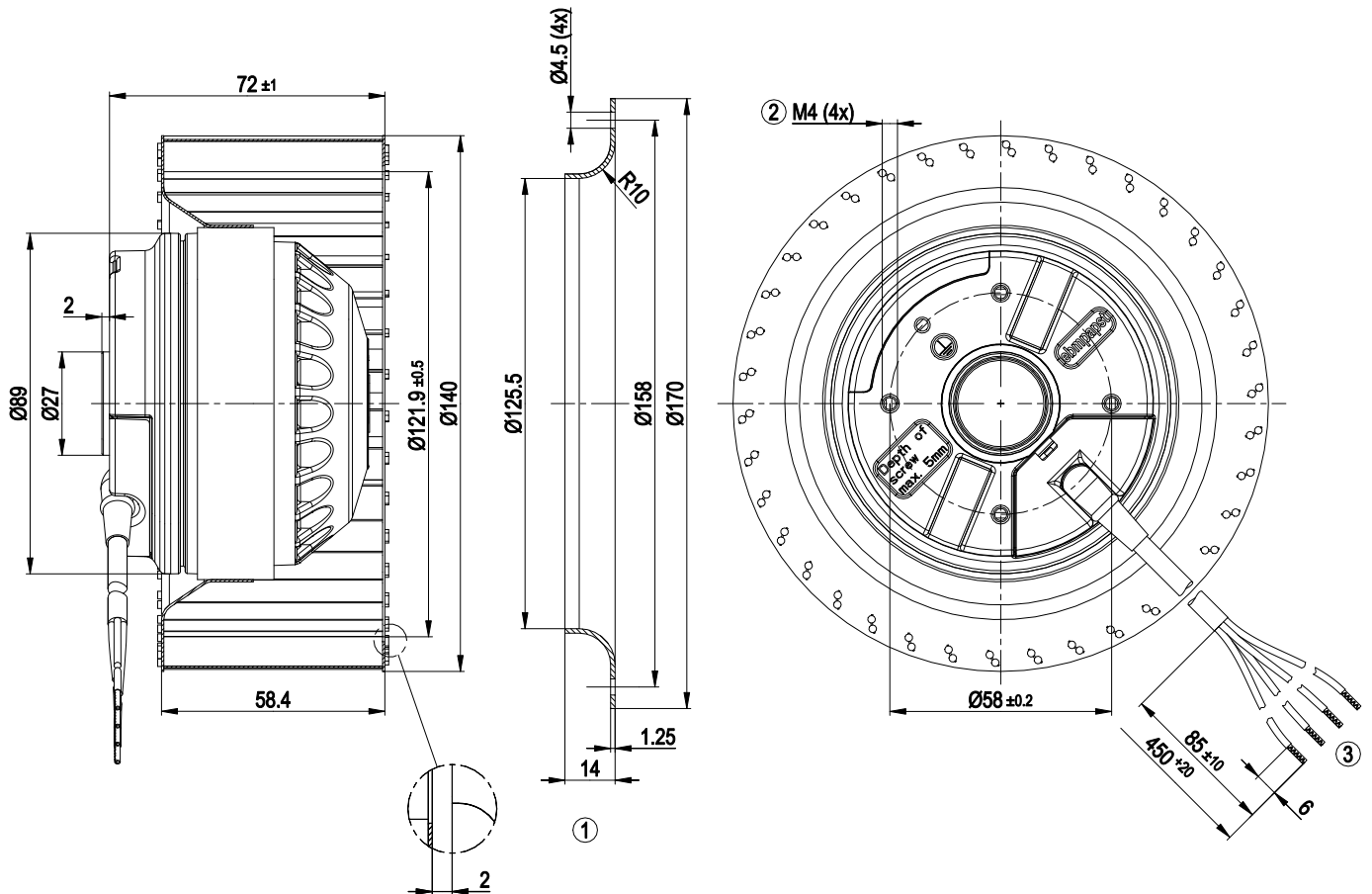

- 1 Accessory part: Inlet ring 09576-2-4013, not included in scope of delivery
- 2 Max. clearance for screw 5 mm
- 3 Cable PVC 4G 0.5 mm², 4x crimped splices

Connection diagram



U1	blue	Z	brown	U2	black
PE	green/yellow				



Curves: Air performance 50 Hz

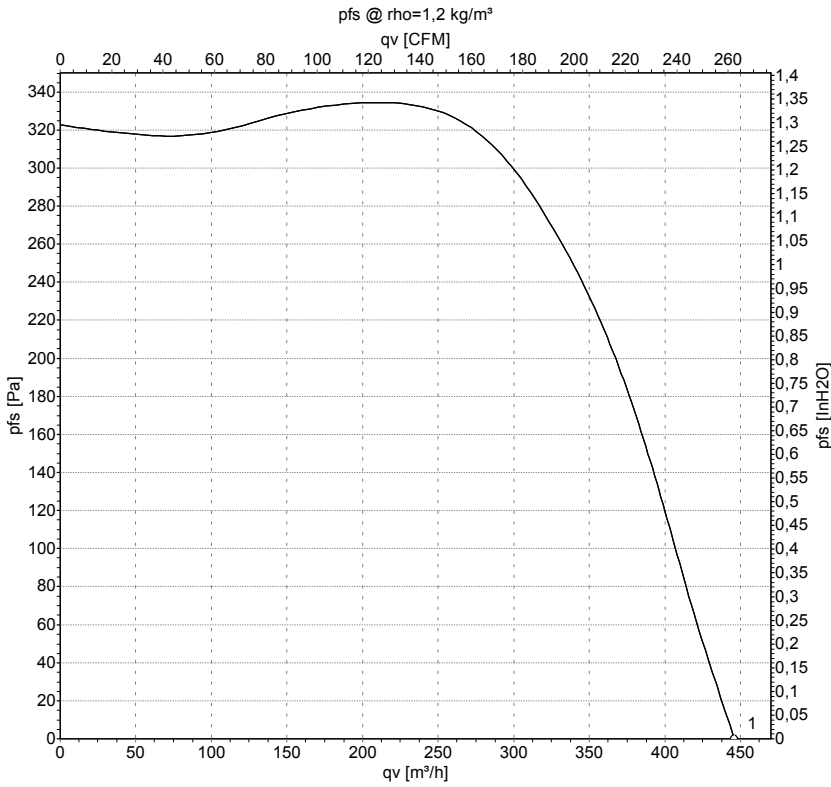

Measurement: LU-3495-1

Air performance measured according to ISO 5801 installation category A. For detailed information on the measurement setup, contact ebm-papst. Intake sound level: Sound power level according to ISO 13347 / sound pressure level measured at 1 m distance from fan axis. The values given are valid under the specified measuring conditions and may vary due to conditions of installation. For deviations from the standard configuration, the parameters have to be checked on the installed unit.

Measured values

	U	f	n	P _e	I	q _v	q _v	P _{fs}
	V	Hz	min ⁻¹	W	A	m ³ /h	cfm	in. wg
1	230	50	1700	130	0.57	445	265	0.00

U = Power supply · f = Frequency · n = Speed (rpm) · P_e = Power consumption · I = Current draw · q_v = Air flow

