

R2D225-RA26-13 ebmpapst Datasheet

sales@fansco.com

www.fansco.com

Limited partnership · Headquarters Mulfingen
County court Stuttgart · HRA 590344General partner Elektrobau Mulfingen GmbH · Headquarters Mulfingen
County court Stuttgart · HRB 590142

Nominal data

Type	R2D225-RA26-13			
Motor	M2D068-DF			
Phase		3~	3~	3~
Nominal voltage	VAC	400	400	480
Connection		Y	Y	Y
Frequency	Hz	50	60	60
Type of data definition		ml	ml	ml
Valid for approval / standard		CE	CE	CE
Speed (rpm)	min ⁻¹	2530	2700	2900
Power input	W	150	200	235
Current draw	A	0.27	0.33	0.33
Min. back pressure	Pa	0	0	0
Min. ambient temperature	°C	-25	-25	-25
Max. ambient temperature	°C	80	55	55
Starting current	A	0.74	0.72	0.83

ml = Max. load · me = Max. efficiency · fa = Running at free air · cs = Customer specs · cu = Customer unit
Subject to alterations

Data according to ErP directive

		Actual	Request 2015			
01 Overall efficiency η_{es}	%	43.6	42.5	09 Power input P_e	kW	0.14
02 Measurement category		A		09 Air flow q_v	m ³ /h	705
03 Efficiency category		Static		09 Pressure increase p_{fs}	Pa	318
04 Efficiency grade N		63.1	62	10 Speed (rpm) n	min ⁻¹	2555
05 Variable speed drive		No		11 Specific ratio*		1.00

Data definition with optimum efficiency.
The ErP data is determined using a motor-impeller combination in a standardised measurement configuration.* Specific ratio = $1 + p_g / 100\,000\text{ Pa}$

LU-140430



Technical features

Mass	2.2 kg
Size	225 mm
Material of impeller	PA plastic
Number of blades	7
Direction of rotation	Clockwise, seen on rotor
Type of protection	IP 44; Depending on installation and position
Insulation class	"F"
Humidity (F)/environmental protection class (H)	F1-1
Max. permissible ambient motor temp. (transp./ storage)	+ 80 °C
Min. permissible ambient motor temp. (transp./storage)	- 40 °C
Mounting position	Any
Condensate discharge holes	None
Operation mode	S1
Motor bearing	Ball bearing
Touch current acc. IEC 60990 (measuring network Fig. 4, TN system)	< 0.75 mA
Motor protection	Thermal overload protector (TOP) brought out, basic insulation
Cable exit	Lateral
Protection class	I (if protective earth is connected by customer)
Product conforming to standard	EN 60335-1; CE

Product drawing

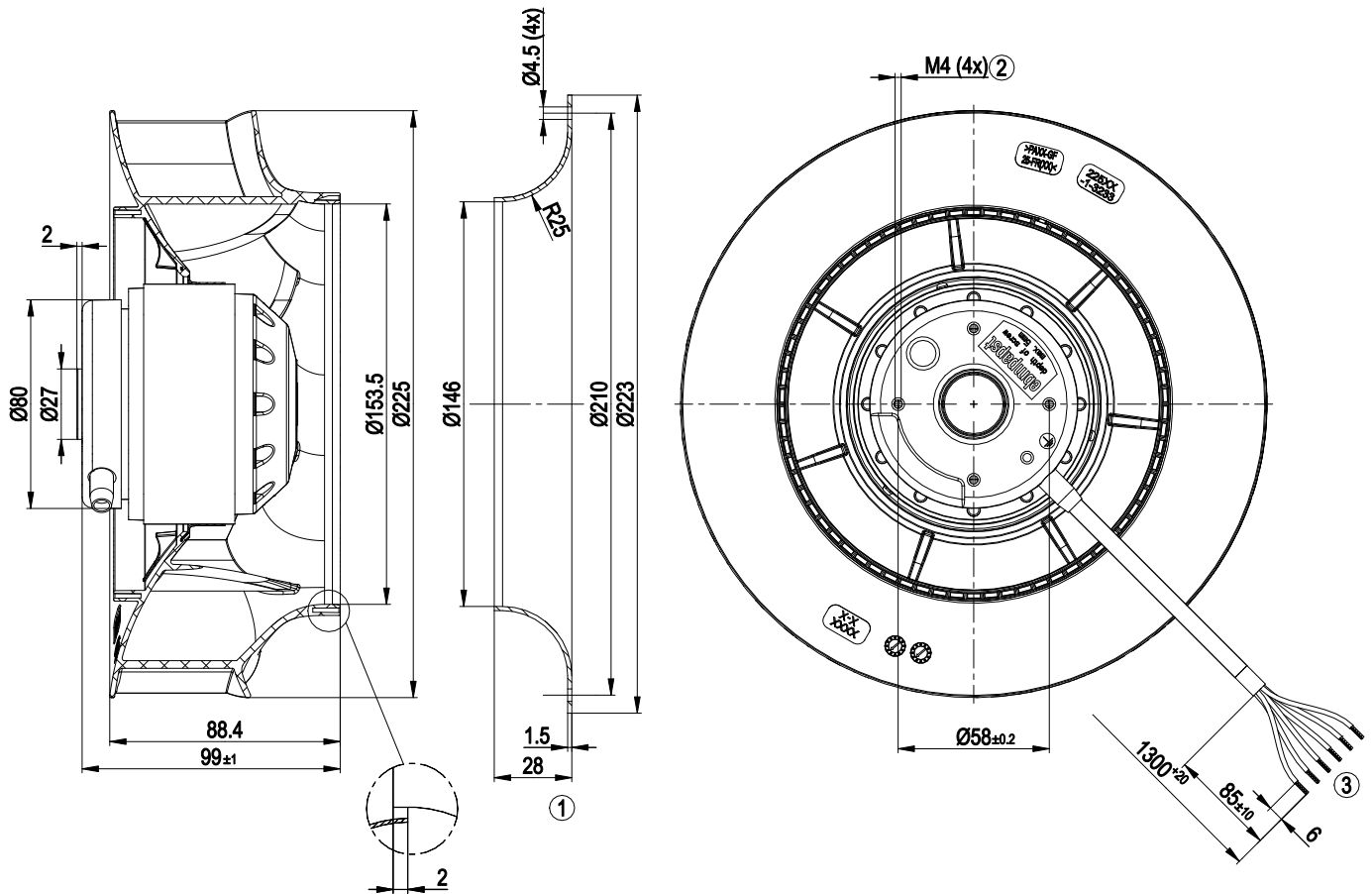

- | | |
|---|---|
| 1 | Accessory part: Inlet nozzle 96358-2-4013 not included in scope of delivery |
| 2 | Thread reach max. 5 mm |
| 3 | Connection line silicone 6G 0.5mm ² , 6x lead tips crimped |

Connection screen

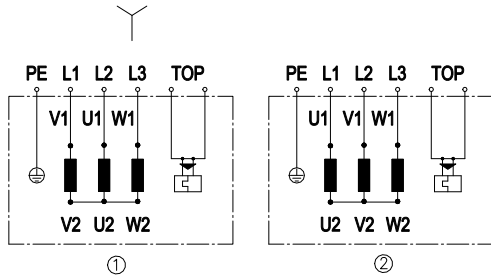

Change direction of rotation by reversing two phases

	Three-phase motor
Y	Star connection
1	Anti-clockwise operation
L1	= V1 = blue
L2	= U1 = black
L3	= W1 = brown
2	Clockwise operation
L1	= U1 = black
L2	= V1 = blue
L3	= W1 = brown
PE	green/yellow
TOP	2x grey

Charts: Air flow 50 Hz

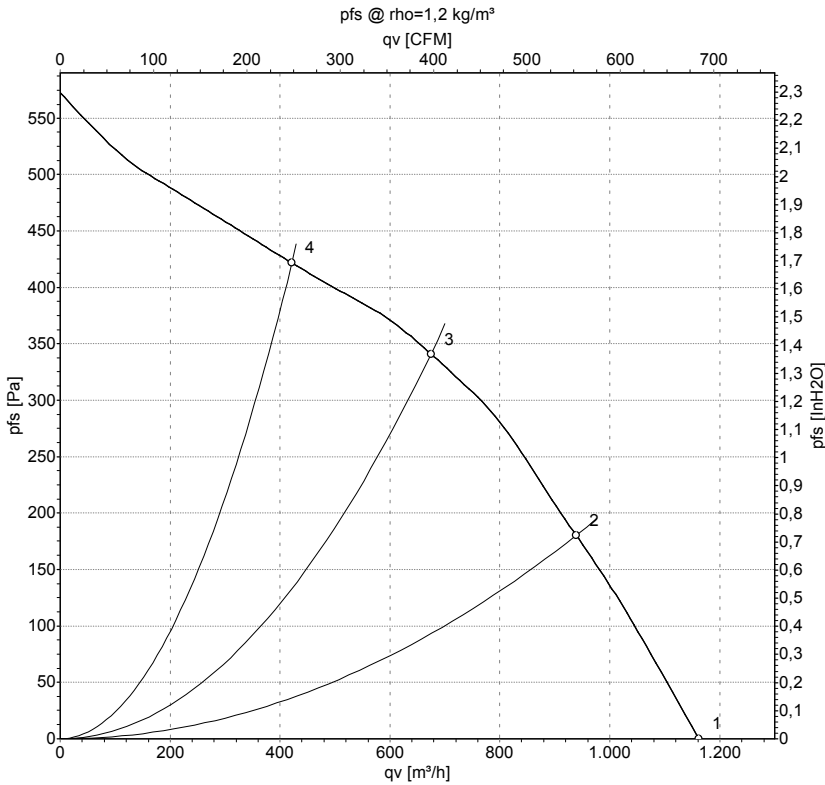

Measurement: LU-140430-1

Air performance measured as per ISO 5801 Installation category A. For detailed information on the measuring set-up, please contact ebm-papst. Suction-side noise levels: LwA measured as per ISO 13347 / LpA measured with 1m distance to fan axis. The values given are valid under the measuring conditions mentioned above and may vary according to the actual installation situation. With any deviation from the standard set-up, the specific values have to be checked and reviewed with the unit installed.

Measured values

	U	f	n	P _e	I	LpA _{in}	LwA _{in}	q _v	p _{fs}	q _v	p _{fs}
	V	Hz	min ⁻¹	W	A	dB(A)	dB(A)	m ³ /h	Pa	cfm	inH2O
1	400	50	2645	122	0.24	66	74	1160	0	685	0.00
2	400	50	2530	150	0.27	61	69	940	180	555	0.72
3	400	50	2555	141	0.26	57	65	675	340	395	1.36
4	400	50	2600	128	0.24	62	70	420	420	250	1.69

U = Supply voltage · f = Frequency · n = Speed (rpm) · P_e = Power input · I = Current draw · LpA_{in} = Sound pressure level inlet side · LwA_{in} = Sound power level inlet side · q_v = Air flow
 p_{fs} = Pressure increase



Charts: Air flow 60 Hz

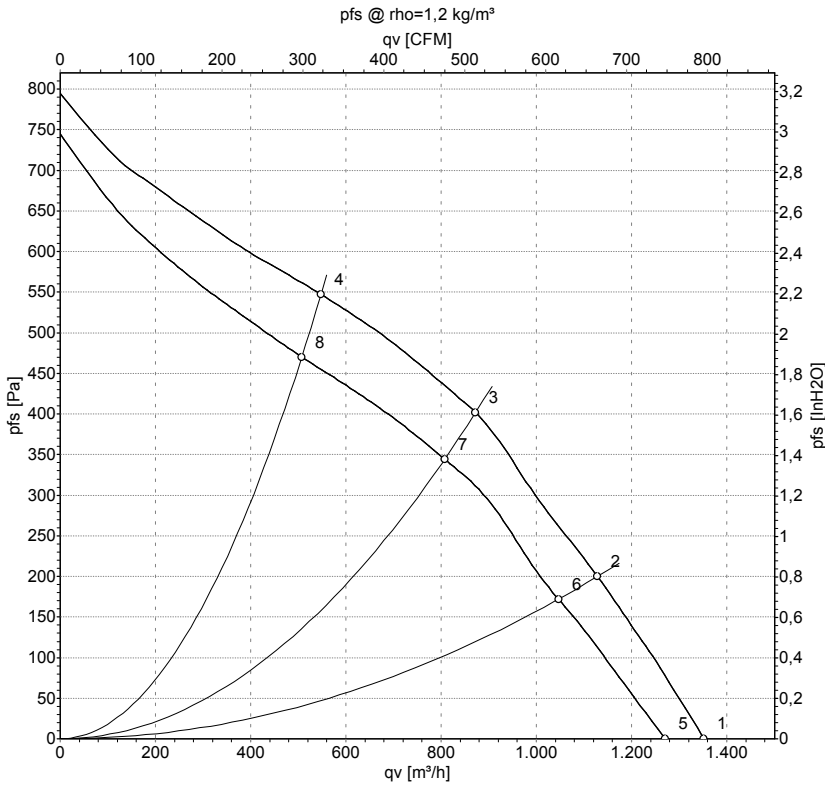

Measurement: LU-140437-1
Measurement: LU-140433-1

Air performance measured as per ISO 5801 Installation category A. For detailed information on the measuring set-up, please contact ebm-papst. Suction-side noise levels: LwA measured as per ISO 13347 / LpA measured with 1m distance to fan axis. The values given are valid under the measuring conditions mentioned above and may vary according to the actual installation situation. With any deviation from the standard set-up, the specific values have to be checked and reviewed with the unit installed.

Measured values

	U	f	n	P _e	I	LpA _{in}	LwA _{in}	q _v	p _{fs}	q _v	p _{fs}
	V	Hz	min ⁻¹	W	A	dB(A)	dB(A)	m³/h	Pa	cfm	inH2O
1	480	60	3065	192	0.28	70	78	1350	0	795	0.00
2	480	60	2940	225	0.32	66	74	1130	200	665	0.80
3	480	60	2900	235	0.33	61	69	870	400	515	1.61
4	480	60	3000	209	0.30	64	73	545	550	320	2.21
5	400	60	2880	171	0.28	69	76	1270	0	745	0.00
6	400	60	2725	197	0.32	65	72	1045	172	615	0.69
7	400	60	2700	200	0.33	60	68	805	345	475	1.39
8	400	60	2775	186	0.30	64	74	505	470	300	1.89

U = Supply voltage · f = Frequency · n = Speed (rpm) · P_e = Power input · I = Current draw · LpA_{in} = Sound pressure level inlet side · LwA_{in} = Sound power level inlet side · q_v = Air flow
p_{fs} = Pressure increase

