

R2D225-AG02-12 ebmpapst Datasheet

sales@fansco.com

www.fansco.com

Nominal data

Type	R2D225-AG02-12				
Motor	M2D068-EC				
Phase		3~	3~	3~	3~
Nominal voltage	VAC	230	230	400	400
Wiring		Δ	Δ	Y	Y
Frequency	Hz	50	60	50	60
Method of obtaining data		fa	fa	fa	fa
Valid for approval/standard		CE	CE	CE	CE
Speed (rpm)	min ⁻¹	2700	3000	2700	3000
Power consumption	W	165	250	165	250
Current draw	A	0.50	0.67	0.29	0.39
Min. back pressure	Pa	0	0	0	0
Min. back pressure	in. wg	0	0	0	0
Min. ambient temperature	°C	-25	-25	-25	-25
Max. ambient temperature	°C	105	75	105	75
Starting current	A	1.73	1.65	1.0	0.95

ml = Max. load · me = Max. efficiency · fa = Free air · cs = Customer specification · ce = Customer equipment
Subject to change



Technical description

Weight	4 kg
Size	225 mm
Motor size	68
Rotor surface	Unpainted
Motor suspension	Motor mounted with brackets on one side
Direction of rotation	Clockwise, viewed toward rotor
Degree of protection	IP20
Insulation class	"F"
Moisture (F) / Environmental (H) protection class	F1-1; H0+
Max. permitted ambient temp. for motor (transport/storage)	+ 80 °C
Min. permitted ambient temp. for motor (transport/storage)	- 40 °C
Installation position	Shaft horizontal
Condensation drainage holes	None
Mode	S1
Motor bearing	Ball bearing
Touch current according to IEC 60990 (measuring circuit Fig. 4, TN system)	< 0.75 mA
Electrical hookup	Via terminal strip
With cable	Axial
Protection class	I (if protective earth is connected by customer to the housing's connection point)
Conformity with standards	CE

Product drawing

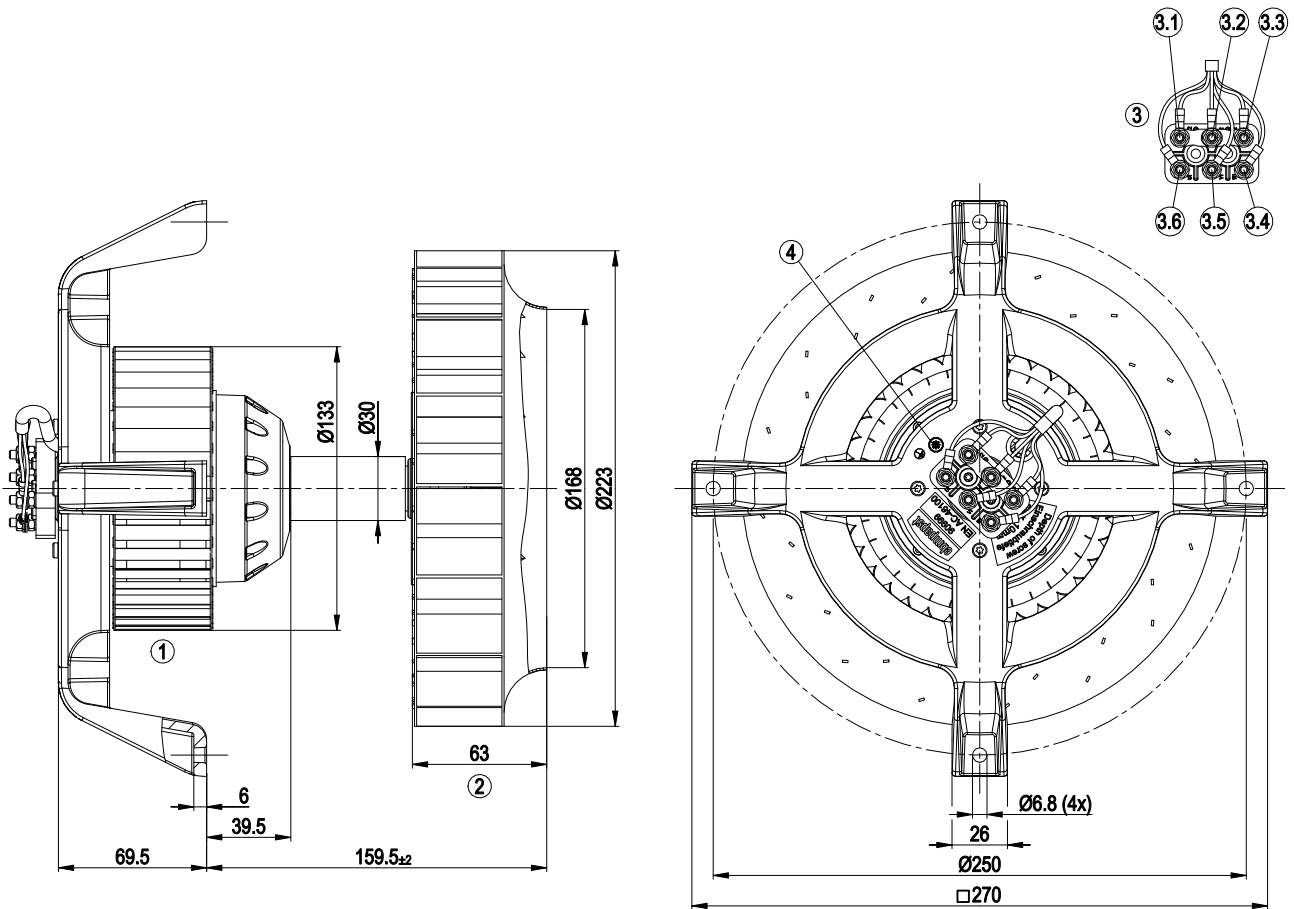

1	Centrifugal fan impeller (sheet steel, galvanized)
2	Centrifugal fan impeller (sheet steel, rust- and acid-resistant)
3.1	yellow
3.2	green
3.3	white
3.4	brown
3.5	blue
3.6	black
4	M4 screw for fastening ground connector
	Max. clearance for screw 5 mm

Connection diagram

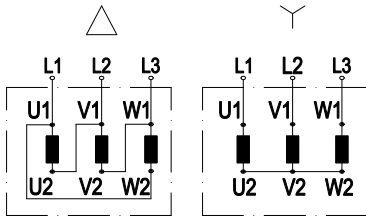

Change of rotation direction by reversing two phases

	Three-phase motor	Δ	Delta connection	Y	Star connection
L1	= U1 = black	L2	= V1 = blue	L3	= W1 = brown
U2	green	V2	white	W2	yellow



Curves: Air performance 50 Hz

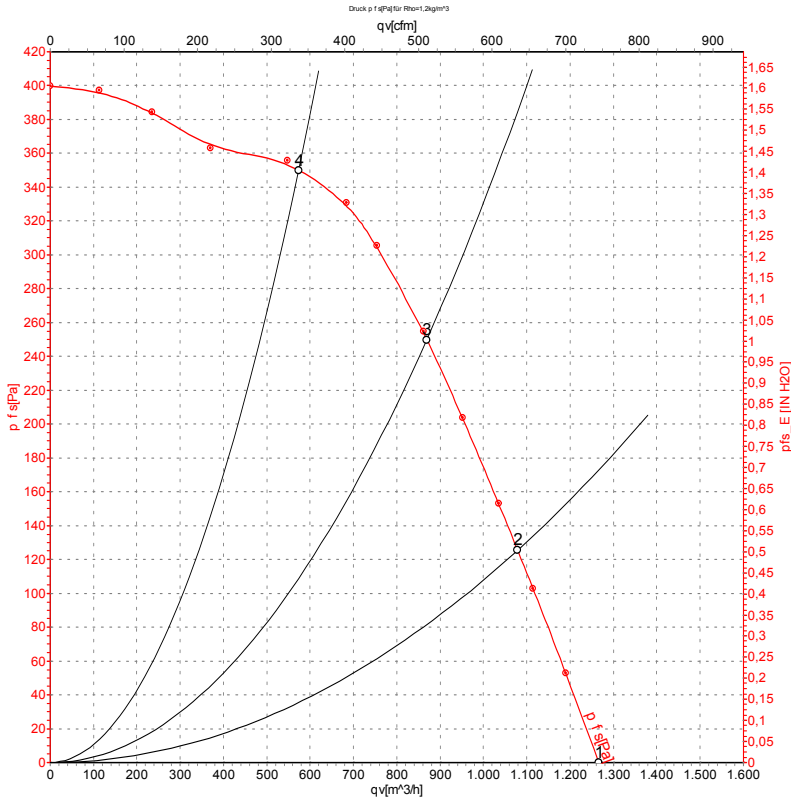

Measurement: LU-23648-1

Air performance measured according to ISO 5801 installation category A. For detailed information on the measurement setup, contact ebmpapst. Intake sound level: Sound power level according to ISO 13347 / sound pressure level measured at 1 m distance from fan axis. The values given are valid under the specified measuring conditions and may vary due to conditions of installation. For deviations from the standard configuration, the parameters have to be checked on the installed unit.

Measured values

	U	f	n	P _e	I	q _v	P _{fs}	q _v	P _{fs}
	V	Hz	min ⁻¹	W	A	m ³ /h	Pa	cfm	in. wg
1	400	50	2700	165	0.29	1265	0	745	0.00
2	400	50	2665	185	0.33	1080	125	635	0.50
3	400	50	2640	197	0.34	870	250	510	1.00
4	400	50	2660	188	0.33	575	350	335	1.41

U = Voltage · f = Frequency · n = Speed (rpm) · P_e = Power consumption · I = Current draw · q_v = Air flow · P_{fs} = Pressure increase



Curves: Air performance 60 Hz

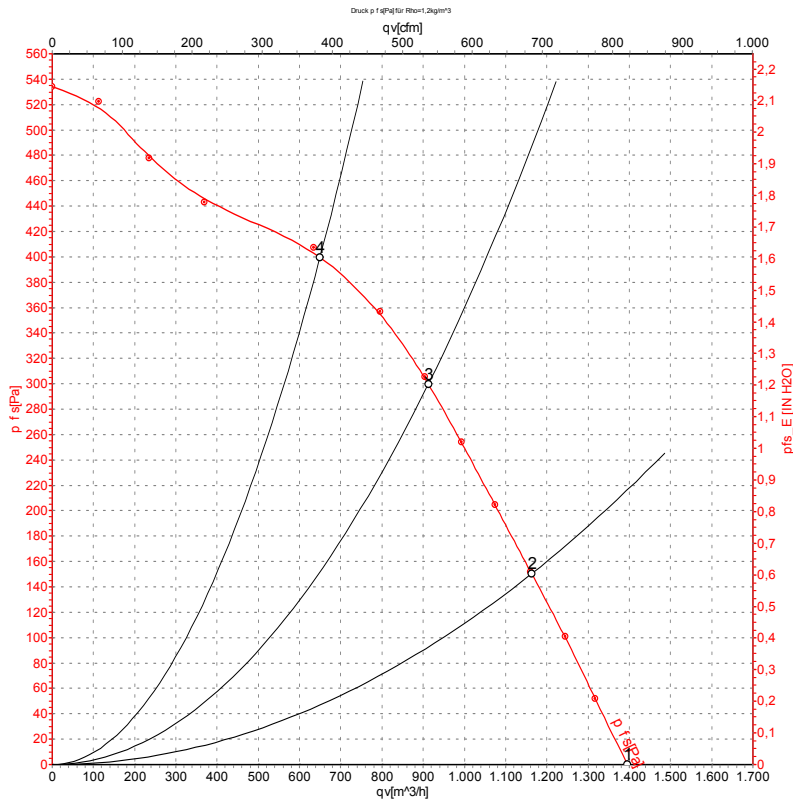

Measurement: LU-23649-1

Air performance measured according to ISO 5801 installation category A. For detailed information on the measurement setup, contact ebmpapst. Intake sound level: Sound power level according to ISO 13347 / sound pressure level measured at 1 m distance from fan axis. The values given are valid under the specified measuring conditions and may vary due to conditions of installation. For deviations from the standard configuration, the parameters have to be checked on the installed unit.

Measured values

	U	f	n	P _e	I	q _v	P _{fs}	q _v	P _{fs}
	V	Hz	min ⁻¹	W	A	m ³ /h	Pa	cfm	in. wg
1	400	60	3000	250	0.39	1395	0	820	0.00
2	400	60	2890	275	0.43	1165	150	685	0.60
3	400	60	2830	290	0.45	915	300	535	1.20
4	400	60	2860	280	0.43	650	400	380	1.61

U = Voltage · f = Frequency · n = Speed (rpm) · P_e = Power consumption · I = Current draw · q_v = Air flow · P_{fs} = Pressure increase

