

R2D220-AB02-19

AC centrifugal fan

backward-curved, single-intake



R2D220-AB02-19 ebmpapst Datasheet

sales@fansco.com

www.fansco.com

Nominal data

Type	R2D220-AB02-19		
Motor	M2D068-DF		
Phase		3~	3~
Nominal voltage	VAC	400	400
Wiring		Y	Y
Frequency	Hz	50	60
Method of obtaining data		fa	fa
Valid for approval/standard		CE	CE
Speed (rpm)	min ⁻¹	2800	3200
Power consumption	W	80	115
Current draw	A	0.2	0.21
Min. back pressure	Pa	0	0
Min. back pressure	in. wg	0	0
Max. ambient temperature	°C	55	55

ml = Max. load · me = Max. efficiency · fa = Free air · cs = Customer specification · ce = Customer equipment
Subject to change



Technical description

Weight	2 kg
Size	220 mm
Motor size	68
Rotor surface	Painted black
Impeller material	PA66 plastic, glass-fiber reinforced
Number of blades	11
Direction of rotation	Clockwise, viewed toward rotor
Degree of protection	IP44; installation- and position-dependent as per EN 60034-5
Insulation class	"B"
Moisture (F) / Environmental (H) protection class	H1+
Max. permitted ambient temp. for motor (transport/storage)	+ 80 °C
Min. permitted ambient temp. for motor (transport/storage)	- 40 °C
Installation position	Shaft horizontal or rotor on bottom; rotor on top on request
Condensation drainage holes	On rotor side
Mode	S1
Motor bearing	Ball bearing
Touch current according to IEC 60990 (measuring circuit Fig. 4, TN system)	< 0.75 mA
With cable	Lateral
Protection class	I (with customer connection of protective earth)
Conformity with standards	EN 60335-1, motor does not have factory-installed overheating protection; CE
Approval	EAC; CSA C22.2 No. 100; UL 1004-1

Product drawing

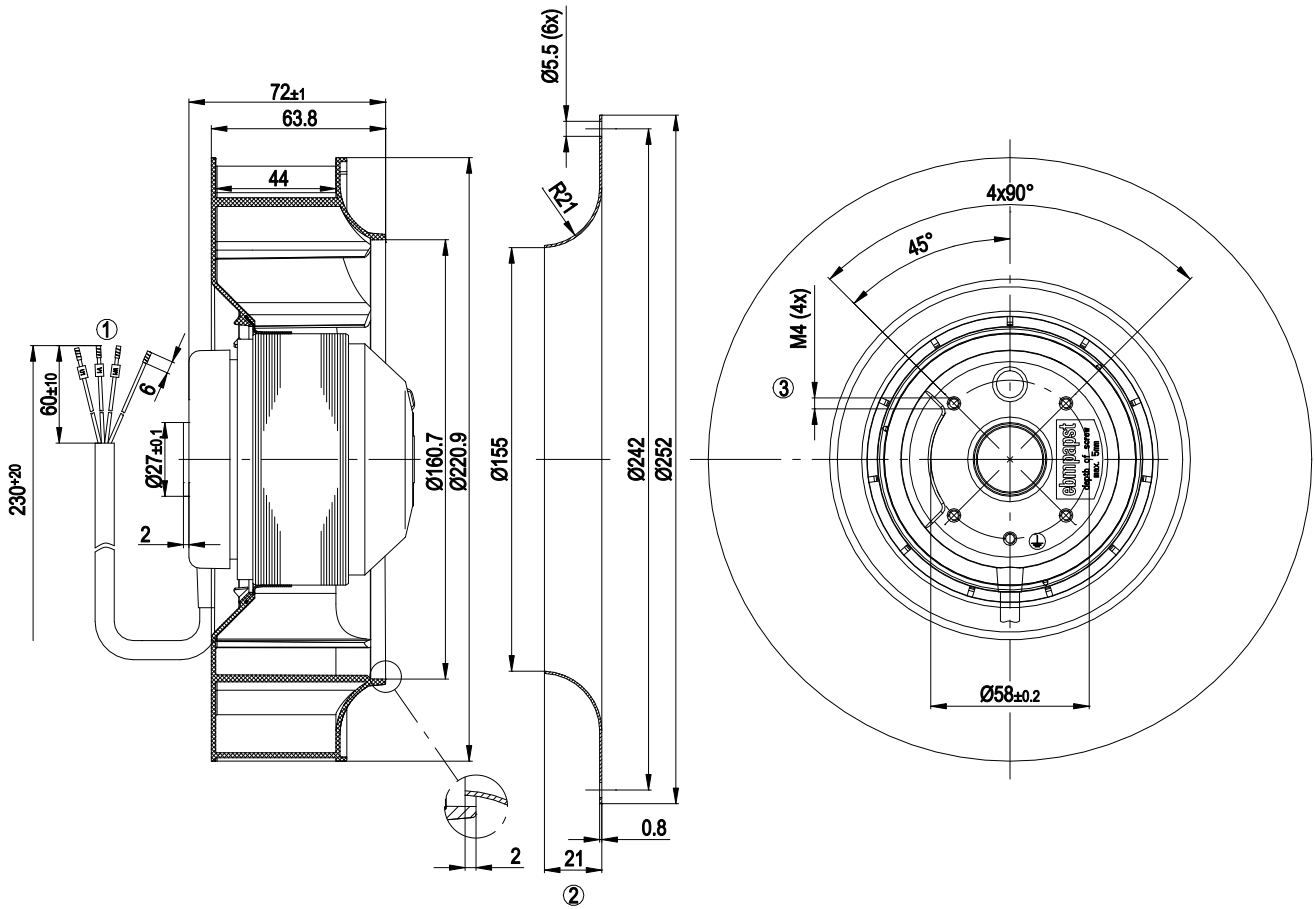

1	Cable PFA AWG20, 4 x crimped splices
2	Accessory part: Inlet ring 09609-2-4013, not included in scope of delivery
3	Max. clearance for screw 5 mm

Connection diagram

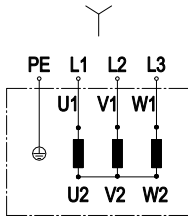

Change of rotation direction by reversing two phases

	Three-phase motor	Y	Star connection	L1	black
L2	blue	L3	brown	PE	green/yellow



Curves: Air performance 50 Hz Y

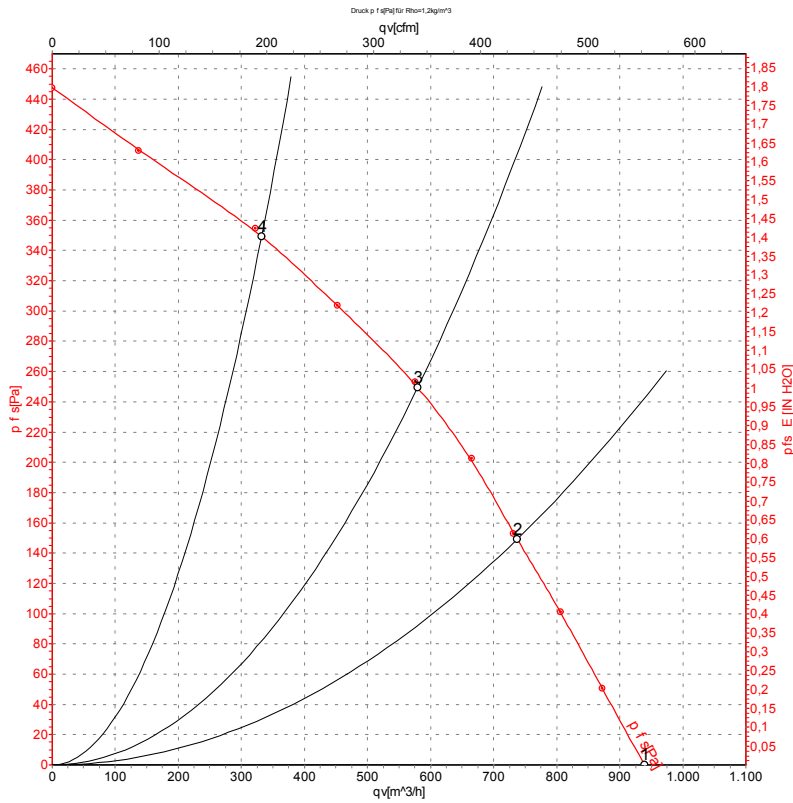

Measurement: LU-45696-1

Air performance measured according to ISO 5801 installation category A. For detailed information on the measurement setup, contact ebm-papst. Intake sound level: Sound power level according to ISO 13347 / sound pressure level measured at 1 m distance from fan axis. The values given are valid under the specified measuring conditions and may vary due to conditions of installation. For deviations from the standard configuration, the parameters have to be checked on the installed unit.

Measured values

	Wired	U	f	n	P _e	I	q _v	P _{fs}	q _v	P _{fs}
		V	Hz	min ⁻¹	W	A	m ³ /h	Pa	cfm	in. wg
1	Y	400	50	2800	80	0.20	940	0	555	0.00
2	Y	400	50	2665	100	0.21	740	150	435	0.60
3	Y	400	50	2630	109	0.22	580	250	340	1.00
4	Y	400	50	2660	102	0.21	330	350	195	1.41

Wired = Wiring · U = Voltage · f = Frequency · n = Speed (rpm) · P_e = Power consumption · I = Current draw · q_v = Air flow · P_{fs} = Pressure increase



Curves: Air performance 60 Hz Y

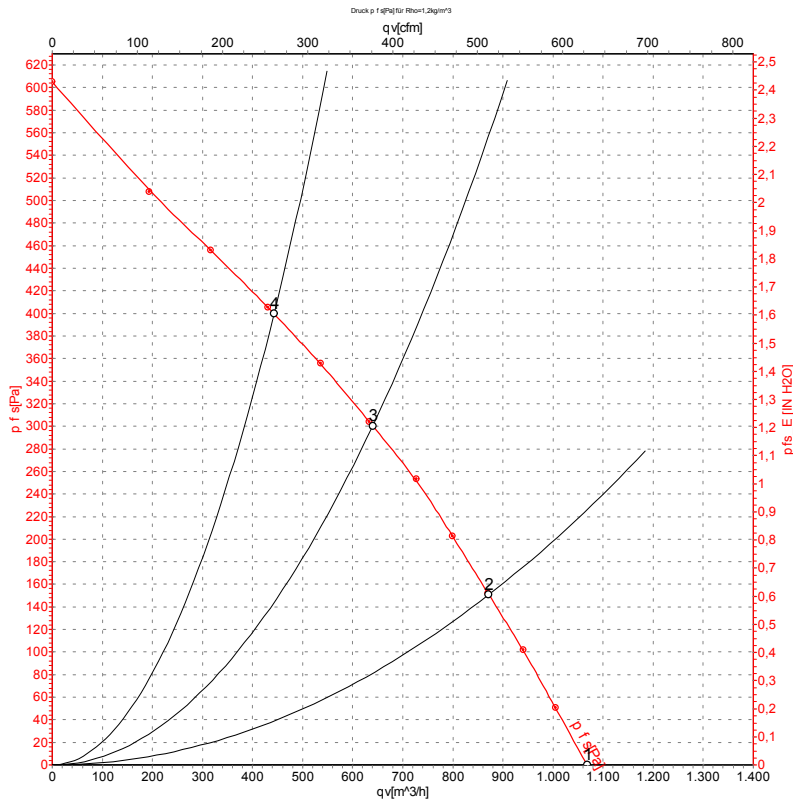

Measurement: LU-45697-1

Air performance measured according to ISO 5801 installation category A. For detailed information on the measurement setup, contact ebm-papst. Intake sound level: Sound power level according to ISO 13347 / sound pressure level measured at 1 m distance from fan axis. The values given are valid under the specified measuring conditions and may vary due to conditions of installation. For deviations from the standard configuration, the parameters have to be checked on the installed unit.

Measured values

	Wired	U	f	n	P _e	I	q _v	P _{fs}	q _v	P _{fs}
		V	Hz	min ⁻¹	W	A	m ³ /h	Pa	cfm	in. wg
1	Y	400	60	3200	115	0.21	1070	0	630	0.00
2	Y	400	60	3000	138	0.23	870	150	515	0.60
3	Y	400	60	2905	155	0.25	640	300	375	1.20
4	Y	400	60	2935	151	0.25	445	400	260	1.61

Wired = Wiring · U = Voltage · f = Frequency · n = Speed (rpm) · P_e = Power consumption · I = Current draw · q_v = Air flow · P_{fs} = Pressure increase

