

R2D190-RA08-09 ebmpapst Datasheet FansCo

sales@fansco.com

www.fansco.com

Nominal data

Type	R2D190-RA08-09		
Motor	M2D068-BF		
Phase		3~	3~
Nominal voltage	VAC	415	415
Connection		Y	Y
Frequency	Hz	50	60
Type of data definition		ml	ml
Valid for approval / standard		CE	CE
Speed (rpm)	min ⁻¹	2370	2480
Power input	W	52	62
Current draw	A	0.1	0.1
Min. back pressure	Pa	0	0
Min. ambient temperature	°C	-25	-25
Max. ambient temperature	°C	80	80
Starting current	A	0.19	0.18

ml = Max. load · me = Max. efficiency · fa = Running at free air · cs = Customer specs · cu = Customer unit
 Subject to alterations



Technical features

Mass	1.3 kg
Size	190 mm
Motor size	68
Surface of rotor	Coated in black
Material of impeller	PP plastic
Number of blades	7
Direction of rotation	Clockwise, seen on rotor
Type of protection	IP44; Depending on installation and position
Insulation class	"F"
Humidity (F) / environmental protection class (H)	H1+
Max. permissible ambient motor temp. (transp./ storage)	+ 80 °C
Min. permissible ambient motor temp. (transp./storage)	- 40 °C
Mounting position	Any
Condensation drainage holes	None
Operation mode	S1
Motor bearing	Ball bearing
Touch current acc. IEC 60990 (measuring network Fig. 4, TN system)	< 0.75 mA
Electrical connection	Connector with connection line
Motor protection	Thermal overload protector (TOP) brought out, basic insulation
Cable exit	Axial
Protection class	I (if protective earth is connected by customer)
Product conforming to standard	EN 60335-1; CE
Approval	UL 1004-1; CSA C22.2 no. 100

Product drawing

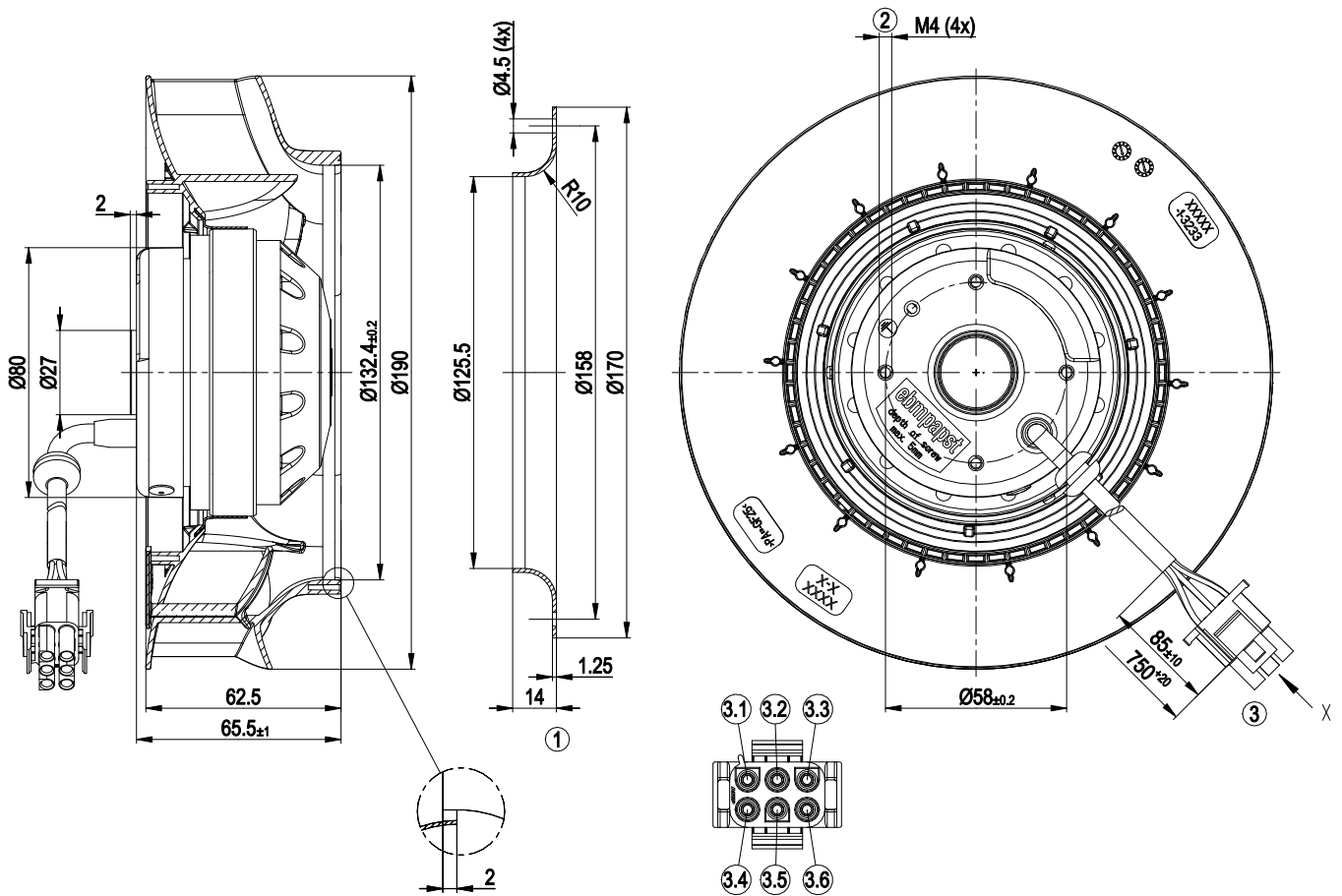

1	Accessory part: Inlet nozzle 09576-2-4013 not included in scope of delivery
2	Screw depth max. 5 mm
3	Connection line PFA AWG20 (green/yellow AWG18), connector housing 6-pole tyco 1-1644055-3, 6x plug pin tyco 926885-1
3.1	black
3.2	blue
3.3	brown
3.4	green/yellow
3.5	grey (TOP)
3.6	grey (TOP)

Connection screen

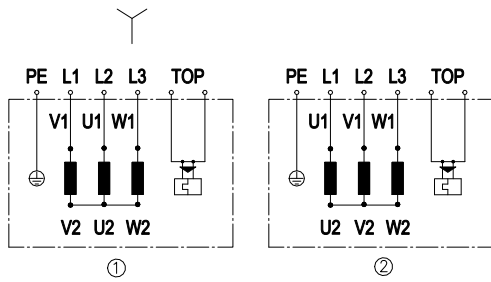

Change direction of rotation by reversing two phases

	Three-phase motor
Y	Star connection
1	Anti-clockwise operation
L1	= V1 = blue
L2	= U1 = black
L3	= W1 = brown
2	Clockwise operation
L1	= U1 = black
L2	= V1 = blue
L3	= W1 = brown
PE	green/yellow
TOP	2x grey

Charts: Air flow 50 Hz

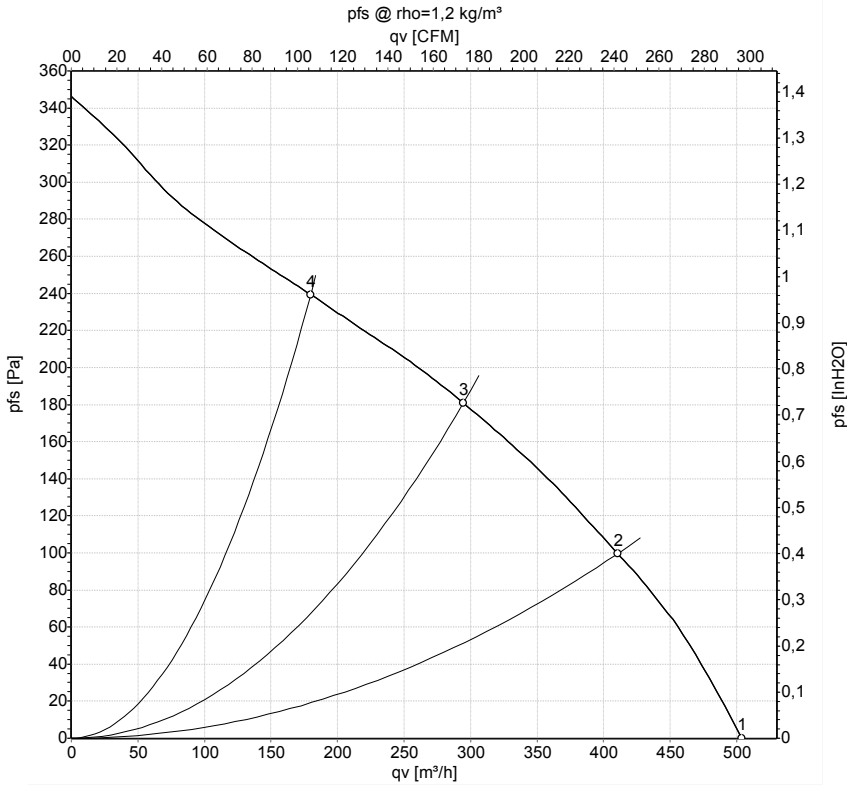

Measurement: LU-160953-1

Air performance measured as per ISO 5801 Installation category A. For detailed information on the measuring set-up, please contact ebm-papst. Suction-side noise levels: L_{wA} measured as per ISO 13347 / L_{pA} measured with 1m distance to fan axis. The values given are valid under the measuring conditions mentioned above and may vary according to the actual installation situation. With any deviation from the standard set-up, the specific values have to be checked and reviewed with the unit installed.

Measured values

	Conn.	U	f	n	P _e	I	q _v	P _{fs}	q _v	P _{fs}
		V	Hz	min ⁻¹	W	A	m ³ /h	Pa	cfm	in. wg
1	Y	415	50	2495	45	0.09	505	0	295	0.00
2	Y	415	50	2435	48	0.09	410	100	240	0.40
3	Y	415	50	2370	52	0.10	295	180	175	0.72
4	Y	415	50	2430	48	0.09	180	240	105	0.96

Conn. = Connection · U = Supply voltage · f = Frequency · n = Speed (rpm) · P_e = Power input · I = Current draw · q_v = Air flow · p_e = Pressure increase



Charts: Air flow 60 Hz

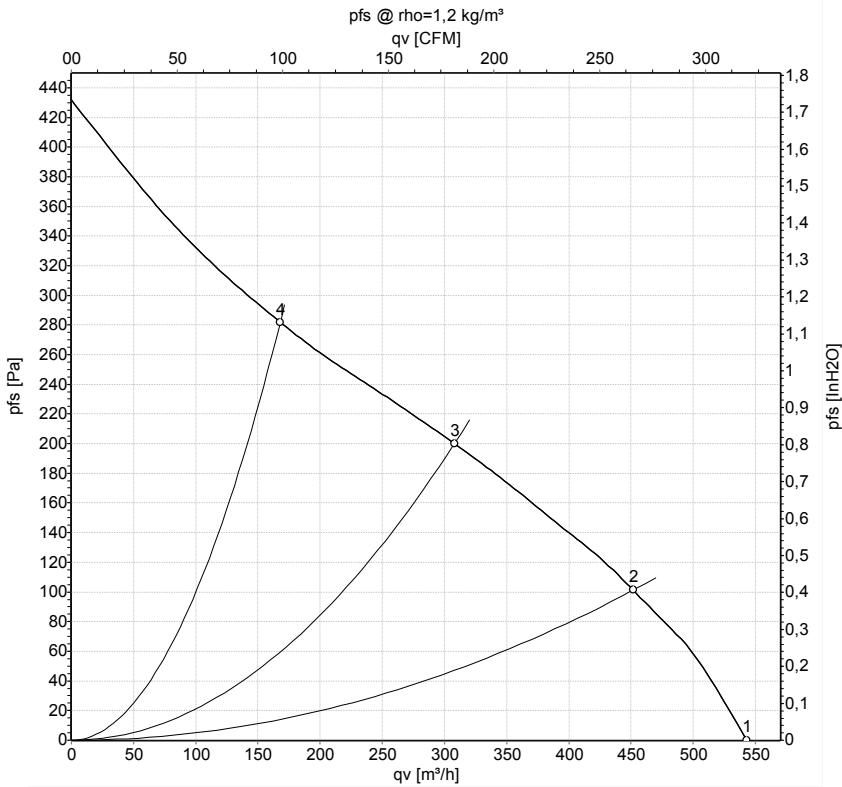

Measurement: LU-160954-1

Air performance measured as per ISO 5801 Installation category A. For detailed information on the measuring set-up, please contact ebm-papst. Suction-side noise levels: LwA measured as per ISO 13347 / LpA measured with 1m distance to fan axis. The values given are valid under the measuring conditions mentioned above and may vary according to the actual installation situation. With any deviation from the standard set-up, the specific values have to be checked and reviewed with the unit installed.

Measured values

	Conn.	U	f	n	P _e	I	q _v	P _{fs}	q _v	P _{fs}
		V	Hz	min ⁻¹	W	A	m ³ /h	Pa	cfm	in. wg
1	Y	415	60	2680	54	0.09	545	0	320	0.00
2	Y	415	60	2605	57	0.09	450	100	265	0.40
3	Y	415	60	2480	62	0.10	310	200	180	0.80
4	Y	415	60	2605	56	0.09	170	282	100	1.13

Conn. = Connection · U = Supply voltage · f = Frequency · n = Speed (rpm) · P_e = Power input · I = Current draw · q_v = Air flow · p_s = Pressure increase

