

R2D190-AC08-13 ebmpapst Datasheet

sales@fansco.com

www.fansco.com

Nominal data

Type	R2D190-AC08-13				
Motor	M2D068-BF				
Phase		3~	3~	3~	3~
Nominal voltage	VAC	230	230	400	400
Connection		Δ	Δ	Y	Y
Frequency	Hz	50	60	50	60
Type of data definition		fa	fa	fa	fa
Valid for approval / standard		CE	CE	CE	CE
Speed	min ⁻¹	2450	2600	2450	2600
Power input	W	43	53	43	53
Current draw	A	0.16	0.16	0.09	0.09
Min. back pressure	Pa	0	0	0	0
Min. ambient temperature	°C	-25	-25	-25	-25
Max. ambient temperature	°C	55	55	55	55
Starting current	A	0.35	0.35	0.2	0.2

ml = max. load · me = max. efficiency · fa = running at free air · cs = customer specs · cu = customer unit
 Subject to alterations



Technical features

Mass	1.3 kg
Size	190 mm
Surface of rotor	Coated in black
Material of impeller	Plastic PA6, fibreglass-reinforced
Number of blades	7
Direction of rotation	Clockwise, seen on rotor
Type of protection	IP 44; Depending on installation and position as per EN 60034-5
Insulation class	"F"
Humidity class	F2-2
Max. permissible ambient motor temp. (transp./ storage)	+ 80 °C
Min. permissible ambient motor temp. (transp./storage)	- 40 °C
Mounting position	Shaft horizontal or rotor on bottom; rotor on top on request
Condensate discharge holes	Rotor-side
Operation mode	S1
Motor bearing	Ball bearing
Touch current acc. IEC 60990 (measuring network Fig. 4, TN system)	< 0.75 mA
Cable exit	Axial
Protection class	I (if protective earth is connected by customer)
Product conforming to standard	EN 60335-1

AC centrifugal fan

backward curved, single inlet

Product drawing

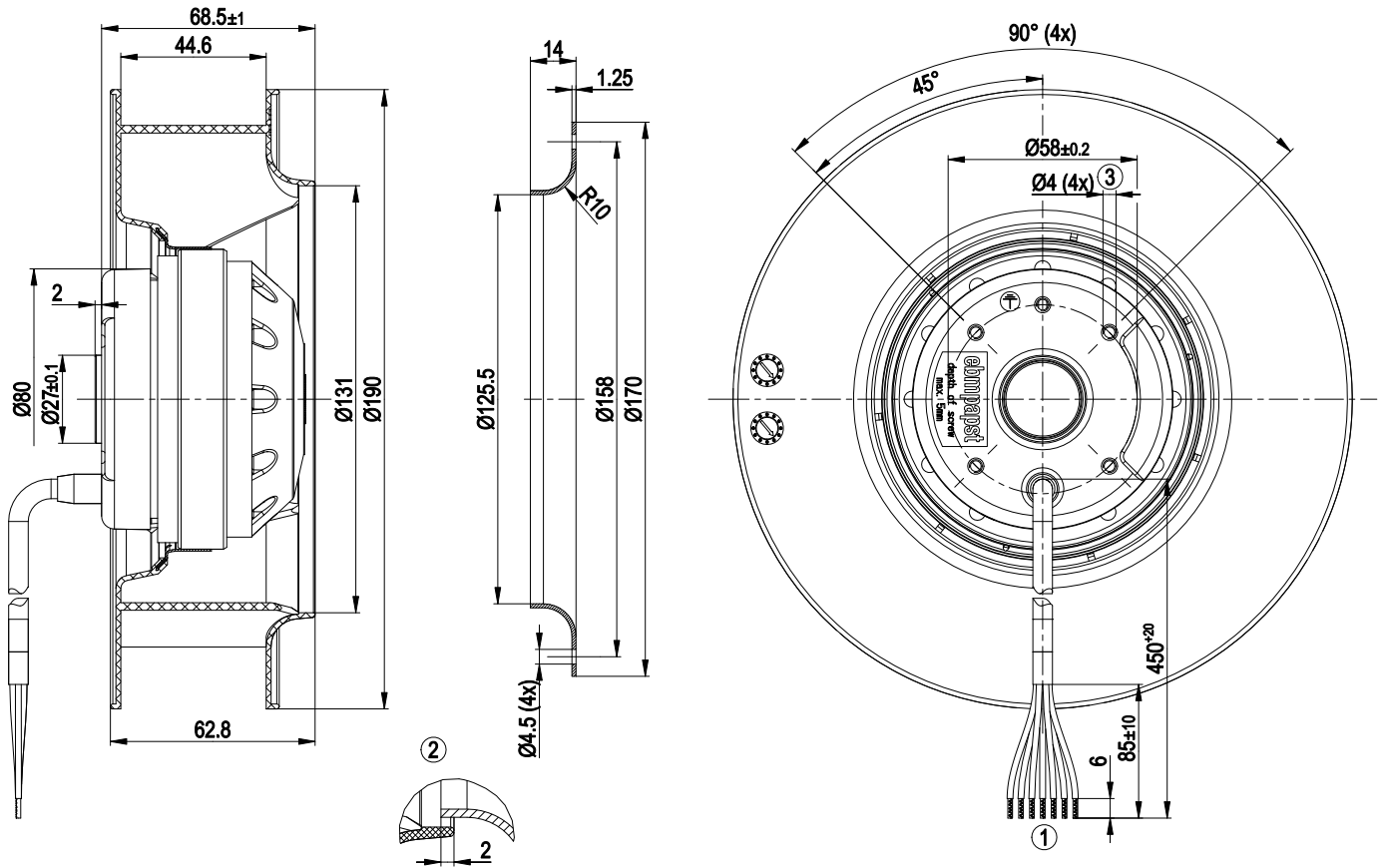

1	Connection line Dipotherm 7G 0.5mm ² , 7x brass lead tips crimped
2	Accessory part: Inlet nozzle 09576-2-4013, not included in the standard scope of delivery
3	Depth of screw max. 5 mm



Connection screen

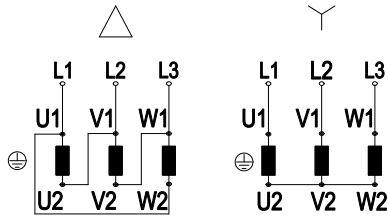

Note: Direction of rotation changes when two phases are reversed

Δ	Delta connection	Y	Star connection	L1	black
L2	blue	L3	brown	U1	black
V1	blue	W1	brown	U2	green
V2	white	W2	yellow		

Charts: Air flow 50 Hz

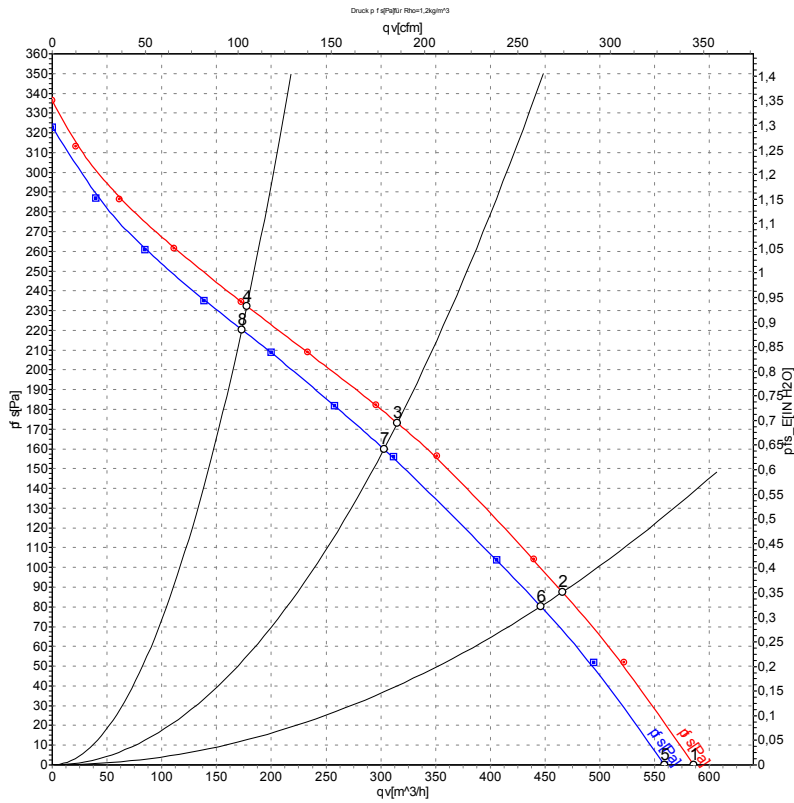

Measurement: LU-50948
Measurement: LU-50798

Air performance measured as per ISO 5801 Installation category A. For detailed information on the measuring set-up, please contact ebmpapst. Suction-side noise levels: LwA measured as per ISO 13347 / LpA measured with 1m distance to fan axis. The values given are valid under the measuring conditions mentioned above and may vary according to the actual installation situation. With any deviation from the standard set-up, the specific values have to be checked and reviewed with the unit installed.

Measured values

	U	f	n	P _e	I	qv	P _{fs}
	V	Hz	min ⁻¹	W	A	m ³ /h	Pa
1	440	50	2550	51	0.11	585	0
2	440	50	2455	55	0.11	465	88
3	440	50	2400	58	0.11	315	173
4	440	50	2460	54	0.10	180	232
5	400	50	2450	43	0.09	560	0
6	400	50	2375	47	0.09	445	80
7	400	50	2310	50	0.09	305	160
8	400	50	2385	46	0.09	175	220

U = Supply voltage · f = Frequency · n = Speed · P_e = Power input · I = Current draw · qv = Air flow · P_{fs} = Pressure increase



Charts: Air flow 60 Hz

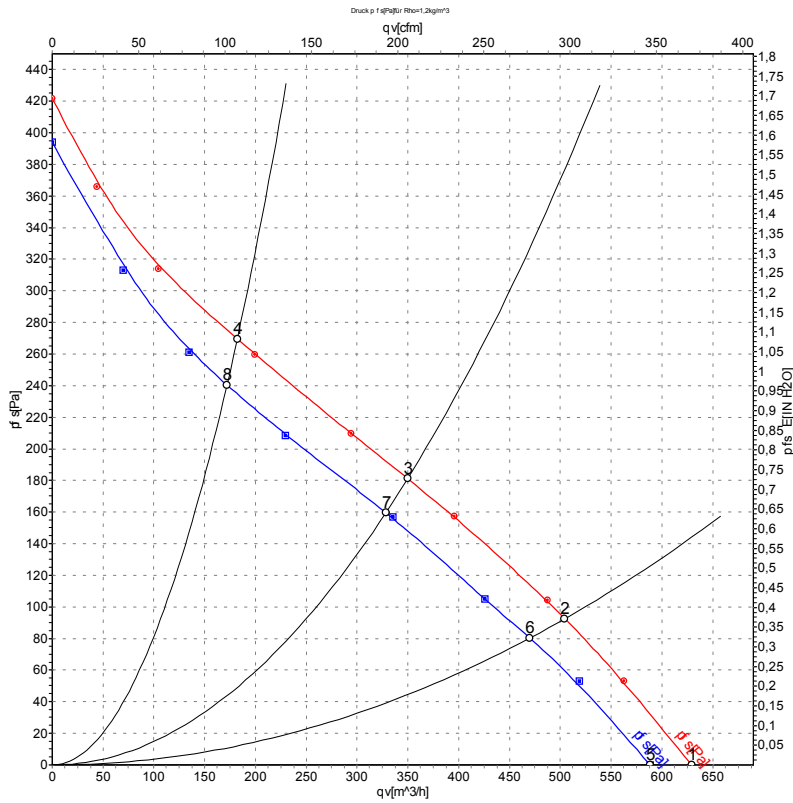

Measurement: LU-50949
Measurement: LU-50800

Air performance measured as per ISO 5801 Installation category A. For detailed information on the measuring set-up, please contact ebmpapst. Suction-side noise levels: LwA measured as per ISO 13347 / LpA measured with 1m distance to fan axis. The values given are valid under the measuring conditions mentioned above and may vary according to the actual installation situation. With any deviation from the standard set-up, the specific values have to be checked and reviewed with the unit installed.

Measured values

	U	f	n	P _e	I	qv	P _{fs}
	V	Hz	min ⁻¹	W	A	m ³ /h	Pa
1	440	60	2700	58	0.09	630	0
2	440	60	2615	63	0.10	505	93
3	440	60	2525	67	0.10	350	181
4	440	60	2635	62	0.10	180	269
5	400	60	2600	53	0.09	590	0
6	400	60	2475	58	0.10	470	80
7	400	60	2375	61	0.10	330	160
8	400	60	2490	57	0.09	170	240

U = Supply voltage · f = Frequency · n = Speed · P_e = Power input · I = Current draw · qv = Air flow · P_{fs} = Pressure increase

