

# AC centrifugal fan

backward-curved, single-intake

R2D175-AE08-09 ebmpapst Datasheet FansCo

sales@fansco.com

www.fansco.com

## Nominal data

Type	R2D175-AE08-09	
Motor	M2D068-BF	
Phase		3~
Nominal voltage	VAC	380
Wiring		Y
Frequency	Hz	50
Method of obtaining data		fa
Valid for approval/standard		CE
Speed (rpm)	min <sup>-1</sup>	2450
Power consumption	W	35
Current draw	A	0.08
Min. ambient temperature	°C	-25
Max. ambient temperature	°C	80

ml = Max. load · me = Max. efficiency · fa = Free air · cs = Customer specification · ce = Customer equipment  
Subject to change



## Technical description

Weight	1.3 kg
Fan size	175 mm
Rotor surface	Unpainted
Impeller material	Sheet steel, galvanized
Number of blades	16
Direction of rotation	Clockwise, viewed toward rotor
Degree of protection	IP44; installation- and position-dependent
Insulation class	"B"
Moisture (F) / Environmental (H) protection class	H0 - dry environment
Max. permitted ambient temp. for motor (transport/storage)	+ 70 °C
Min. permitted ambient temp. for motor (transport/storage)	- 40 °C
Installation position	Any
Condensation drainage holes	None
Mode	S1
Motor bearing	Ball bearing
Touch current according to IEC 60990 (measuring circuit Fig. 4, TN system)	< 0.75 mA
With cable	Axial
Protection class	I (with customer connection of protective earth)
Conformity with standards	EN 60335-1, motor does not have factory-installed overheating protection; CE

## Product drawing

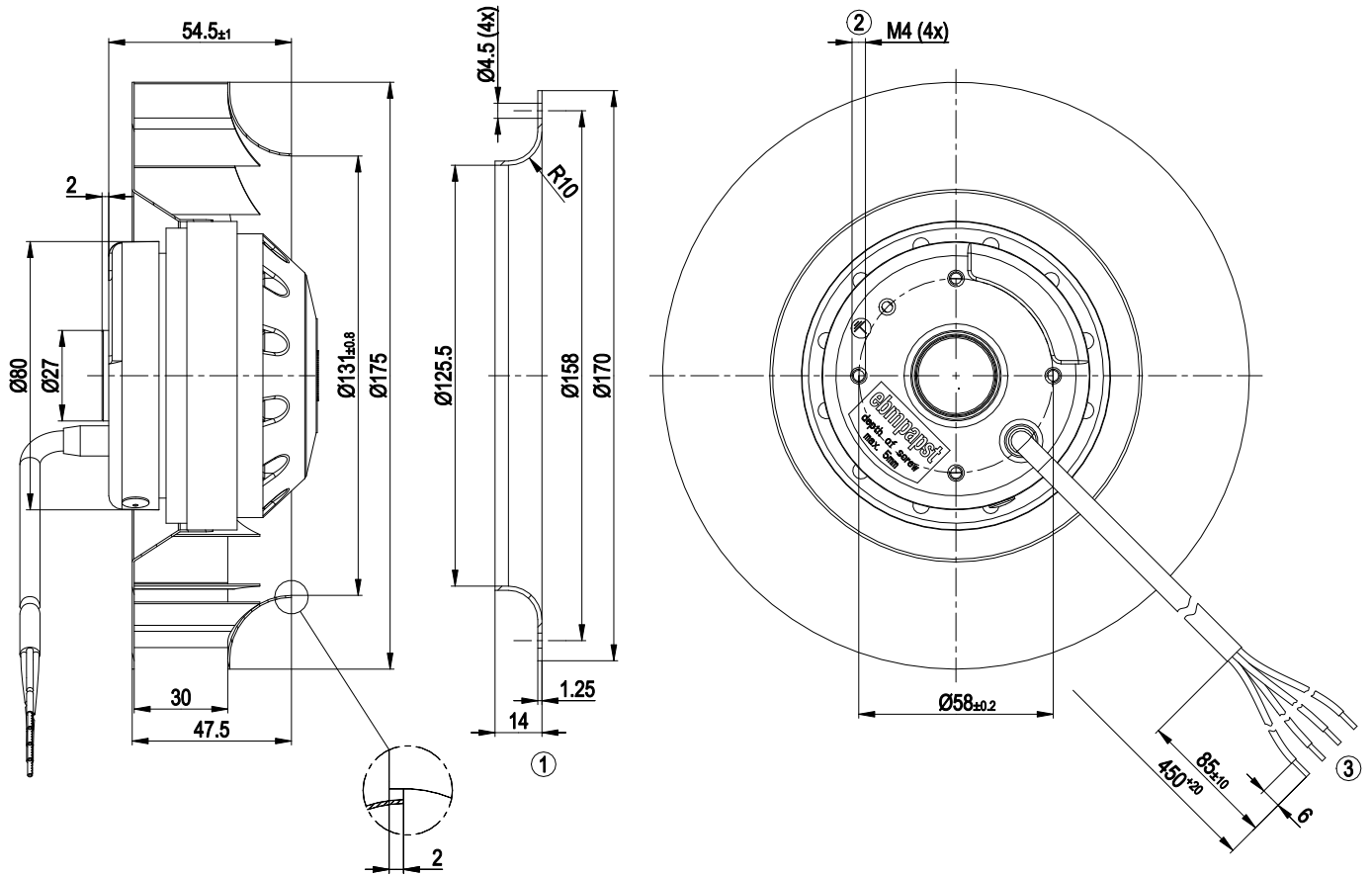

- |   |   |
|---|---|
| 1 | Accessory part: inlet ring 09576-2-4013 not included in scope of delivery |
| 2 | Max. clearance for screw 5 mm   |
| 3 | Cable PVC 4G 0.5 mm <sup>2</sup> , 4x crimped splices                     |

## Connection diagram

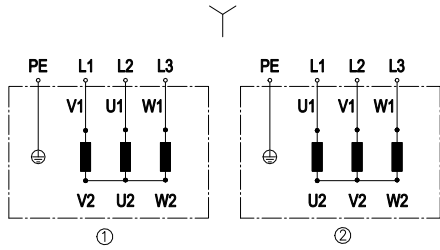

Change of rotation direction by reversing two phases

	Three-phase motor
Y	Star connection
1	Counterclockwise operation
L1	= V1 = blue
L2	= U1 = black
L3	= W1 = brown
2	Clockwise operation
L1	= U1 = black
L2	= V1 = blue
L3	= W1 = brown
PE	green/yellow

## Curves: Air performance 50 Hz

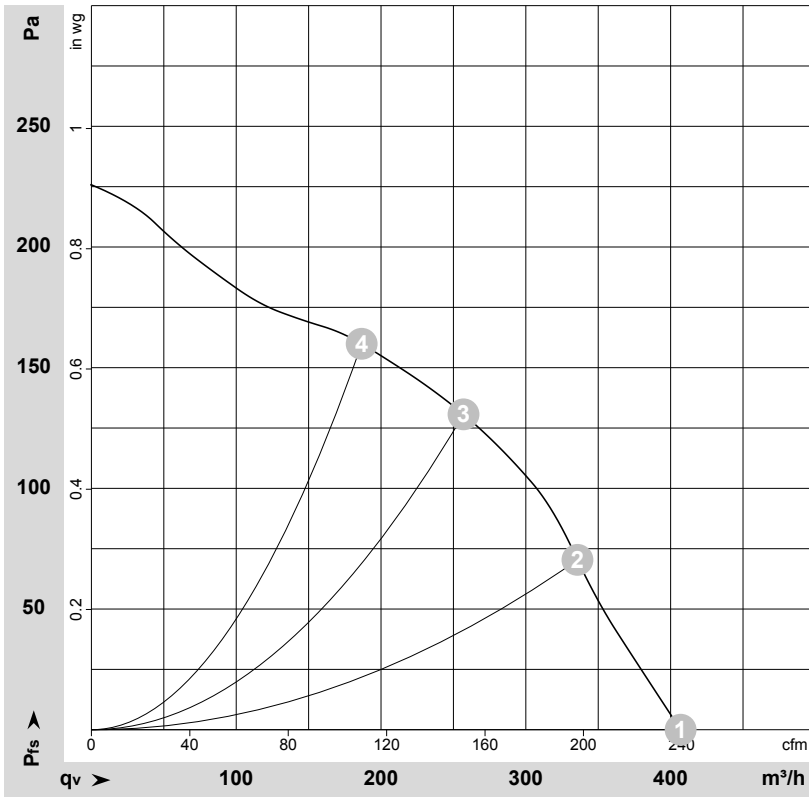

$\rho = 1.15 \text{ kg/m}^3 \pm 2 \%$

Measurement: LU-167117-1

Air performance measured according to ISO 5801 installation category A. For detailed information on the measurement setup, contact ebmpapst. Intake sound level: Sound power level according to ISO 13347 / sound pressure level measured at 1 m distance from fan axis. The values given are valid under the specified measuring conditions and may vary due to conditions of installation. For deviations from the standard configuration, the parameters have to be checked on the installed unit.

## Measured values

	Wired	U	f	n	Pe	I	qv	Pfs	qv	Pfs
		V	Hz	min <sup>-1</sup>	W	A	m <sup>3</sup> /h	Pa	CFM	inH2O
1	Y	400	50	2450	40	0.08	405	0	240	0.00
2	Y	400	50	2385	41	0.08	335	70	200	0.28
3	Y	400	50	2415	40	0.08	255	130	150	0.52
4	Y	400	50	2455	38	0.08	185	160	110	0.64

Wired = Wiring · U = Power supply · f = Frequency · n = Speed (rpm) · Pe = Power consumption · I = Current draw · qv = Air flow · Pfs = Pressure increase

