

R1G250-RC75-03

# EC centrifugal fan - RadiCal

forward curved, single inlet

Automotive



R1G250-RC75-03 ebmpapst Datasheet

[sales@fansco.com](mailto:sales@fansco.com)

[www.fansco.com](http://www.fansco.com)

Limited partnership · Headquarters Mulfingen  
County court Stuttgart · HRA 590344

General partner Elektrobau Mulfingen GmbH · Headquarters Mulfingen  
County court Stuttgart · HRB 590142

## Nominal data

Type	R1G250-RC75-03	
Motor	M1G074-CF	
Nominal voltage	VDC	24
Nominal voltage range	VDC	16 .. 28
Type of data definition		fa
State		prelim.
Speed (rpm)	min <sup>-1</sup>	2550
Power input	W	130
Current draw	A	7.1
Min. ambient temperature	°C	-40
Max. ambient temperature	°C	60

ml = Max. load · me = Max. efficiency · fa = Running at free air · cs = Customer specs · cu = Customer unit  
Subject to alterations



### Technical features

Mass	2.0 kg
Size	250 mm
Surface of rotor	Galvanised
Material of electronics housing	Die-cast aluminium, coated in black
Material of impeller	PA plastic
Number of blades	7
Direction of rotation	Clockwise, seen on rotor
Type of protection	IP 24 KM; Electronics IP 66 / 69 K
Insulation class	"B"
Humidity (F)/environmental protection class (H)	H4
Note ambient temperature	Occasional start-up between -40°C and -25°C is permissible. For continuous operation at ambient temperatures below -25°C (e.g. refrigeration applications) we recommend our fan version with special low-temperature bearings.
Max. permissible ambient motor temp. (transp./ storage)	+70 °C
Min. permissible ambient motor temp. (transp./storage)	-40 °C
Mounting position	Shaft horizontal or rotor on bottom; rotor on top on request
Condensate discharge holes	Rotor-side
Operation mode	S1
Motor bearing	Ball bearing; (sealed)
Technical features	<ul style="list-style-type: none"> <li>- Tach output</li> <li>- Motor current limit</li> <li>- Soft start</li> <li>- Control input 0-10 VDC / PWM</li> <li>- Overvoltage detection</li> <li>- Over-temperature protected electronics</li> </ul>
Motor protection	Reverse polarity and locked-rotor protection
Cable exit	Axial
Approval	EAC

# EC centrifugal fan - RadiCal

forward curved, single inlet

Automotive

## Product drawing

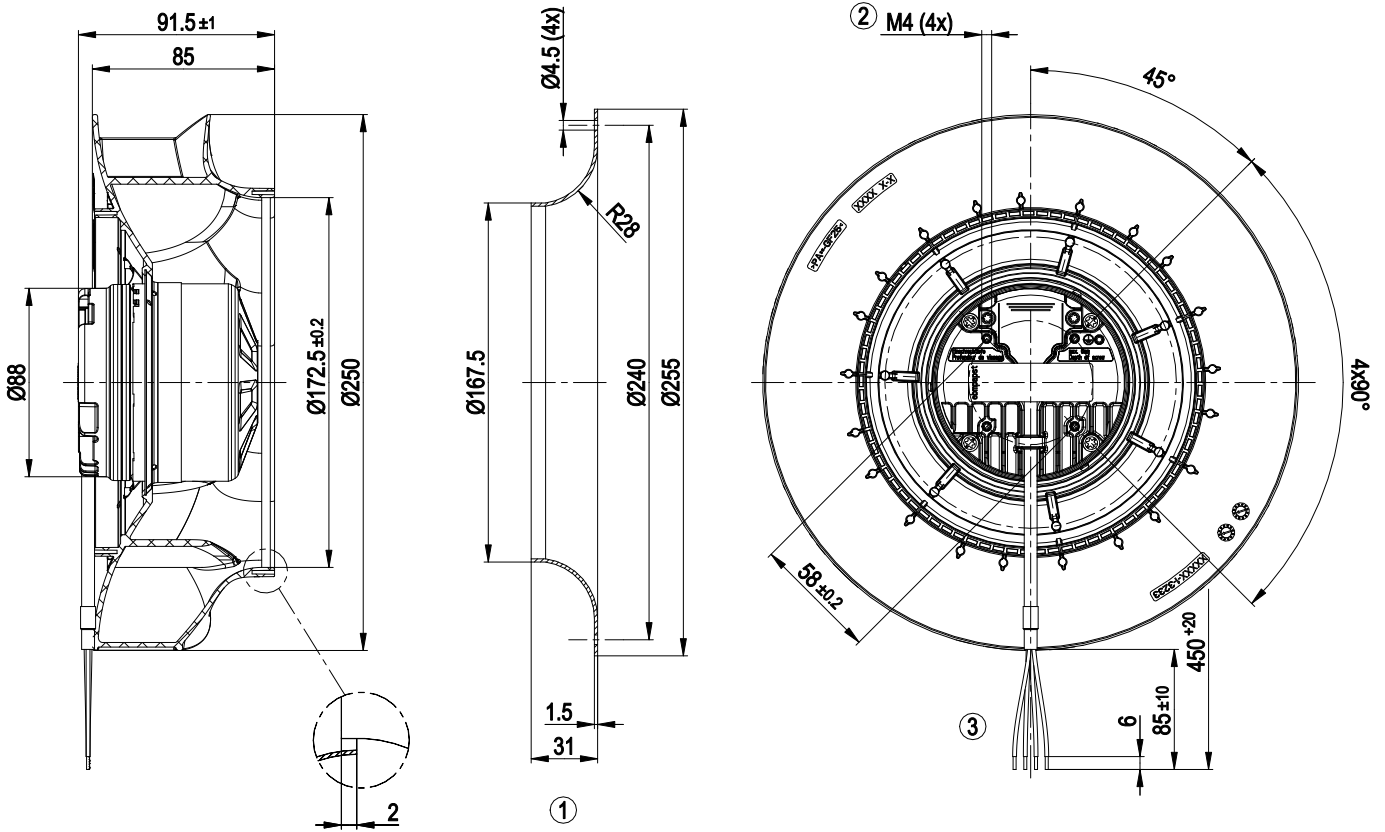

- |   |   |
|---|---|
| 1 | Accessory part: Inlet nozzle 96359-2-4013 not included in scope of delivery |
| 2 | Thread reach max. 6 mm  |
| 3 | Connection line FLRYW 4x 0.75 mm <sup>2</sup> , 4x lead tip crimped         |



# EC centrifugal fan - RadiCal

forward curved, single inlet

Automotive

## Connection screen

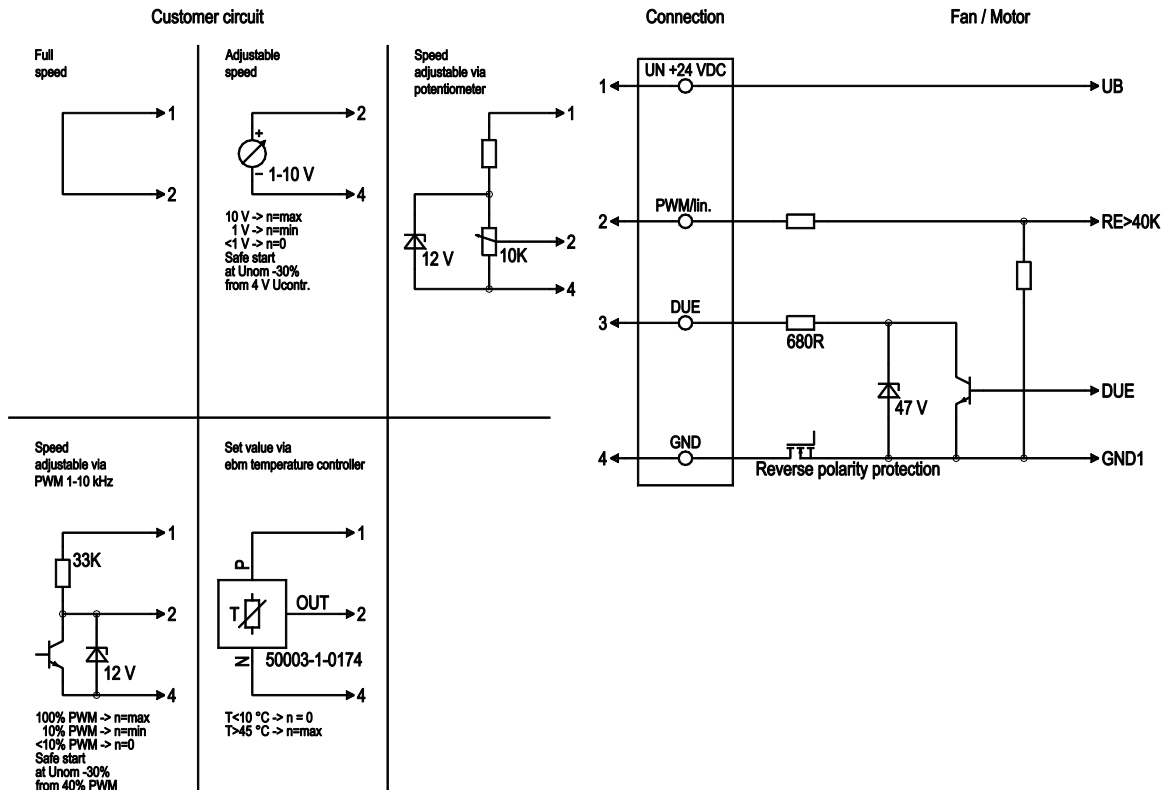

No.	Conn.	Designation	Colour	Function / assignment
	1	UN +24 VDC	red	Power supply 24 VDC, maximum ripple 3.5 %
	2	PWM/LIN	yellow	Control input Re > 40k
	3	DUE	white	Speed monitoring output, 3 pulses per revolution, Isink max = 10 mA
	4	GND	blue	Reference earth



## Charts: Air flow

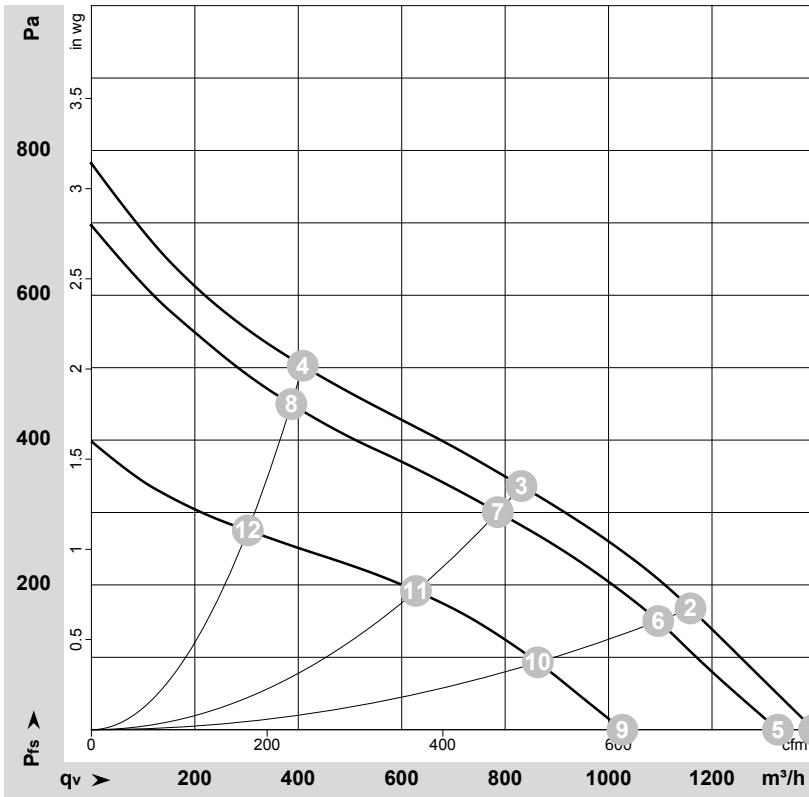

$\rho = 1.15 \text{ kg/m}^3 \pm 2 \%$

Measurement: LU-164866-1  
 Measurement: LU-164801-1  
 Measurement: LU-164863-1

Air performance measured as per ISO 5801 Installation category A. For detailed information on the measuring set-up, please contact ebm-papst. Suction-side noise levels: LwA measured as per ISO 13347 / LpA measured with 1m distance to fan axis. The values given are valid under the measuring conditions mentioned above and may vary according to the actual installation situation. With any deviation from the standard set-up, the specific values have to be checked and reviewed with the unit installed.

## Measured values

	U	n	P <sub>ed</sub>	I	LpA <sub>in</sub>	LwA <sub>in</sub>	q <sub>v</sub>	P <sub>fs</sub>	q <sub>v</sub>	P <sub>fs</sub>
	V	min <sup>-1</sup>	W	A	dB(A)	dB(A)	m <sup>3</sup> /h	Pa	cfm	inH2O
1	28	2695	153	7.84			1395	0	820	0.00
2	28	2580	162	8.43			1160	168	680	0.67
3	28	2510	164	8.66			830	337	490	1.35
4	28	2655	157	8.07			410	502	240	2.02
5	24	2550	130	7.10	68	76	1325	0	780	0.00
6	24	2440	131	7.46	64	71	1095	150	645	0.60
7	24	2370	134	7.74	61	69	785	300	465	1.20
8	24	2510	129	7.22	65	73	385	450	230	1.81
9	16	1980	59	4.78			1025	0	605	0.00
10	16	1925	63	5.11			865	93	510	0.37
11	16	1895	67	5.38			630	192	370	0.77
12	16	1965	60	4.88			300	275	180	1.10

U = Supply voltage · n = Speed (rpm) · P<sub>ed</sub> = Power input · I = Current draw · LpA<sub>in</sub> = Sound pressure level inlet side · LwA<sub>in</sub> = Sound power level inlet side · q<sub>v</sub> = Air flow · p<sub>fs</sub> = Pressure increase

