

R1G220-RD87-03

EC centrifugal fan - RadiCal

backward curved, single inlet

Automotive



R1G220-RD87-03 ebmpapst Datasheet

sales@fansco.com

www.fansco.com

Limited partnership · Headquarters Muldingen
County court Stuttgart · HRA 590344

General partner Elektrobau Muldingen GmbH · Headquarters Muldingen
County court Stuttgart · HRB 590142

Nominal data

Type	R1G220-RD87-03	
Motor	M1G074-BF	
Nominal voltage	VDC	24
Nominal voltage range	VDC	16 .. 28
Type of data definition		fa
Speed (rpm)	min ⁻¹	3030
Power input	W	112
Current draw	A	6.3
Min. ambient temperature	°C	-40
Max. ambient temperature	°C	60

ml = Max. load · me = Max. efficiency · fa = Running at free air · cs = Customer specs · cu = Customer unit
Subject to alterations



Technical features

Mass	1.5 kg
Size	220 mm
Motor size	74
Surface of rotor	Galvanised
Material of electronics housing	Die-cast aluminium, coated in black
Material of impeller	PA plastic
Number of blades	7
Direction of rotation	Clockwise, seen on rotor
Protection rating	IP 24 KM
Type of protection	Electronics IP 66 / 69 K
Insulation class	"B"
Humidity (F) / environmental protection class (H)	H4
Note ambient temperature	Occasional start-up between -40°C and -25°C is permissible. For continuous operation at ambient temperatures below -25°C (e.g. refrigeration applications) we recommend our fan version with special low-temperature bearings.
Max. permissible ambient motor temp. (transp./ storage)	+70 °C
Min. permissible ambient motor temp. (transp./storage)	-40 °C
Mounting position	Shaft horizontal or rotor on bottom; rotor on top on request
Condensation drainage holes	Rotor-side
Operation mode	S1
Motor bearing	Ball bearing; (sealed)
Technical features	<ul style="list-style-type: none"> - Tach output - Motor current limit - Soft start - Control input 0-10 VDC / PWM - Overvoltage detection - Over-temperature protected electronics
Motor protection	Reverse polarity and locked-rotor protection
Cable exit	Axial
Approval	EAC

EC centrifugal fan - RadiCal

backward curved, single inlet

Automotive

Product drawing

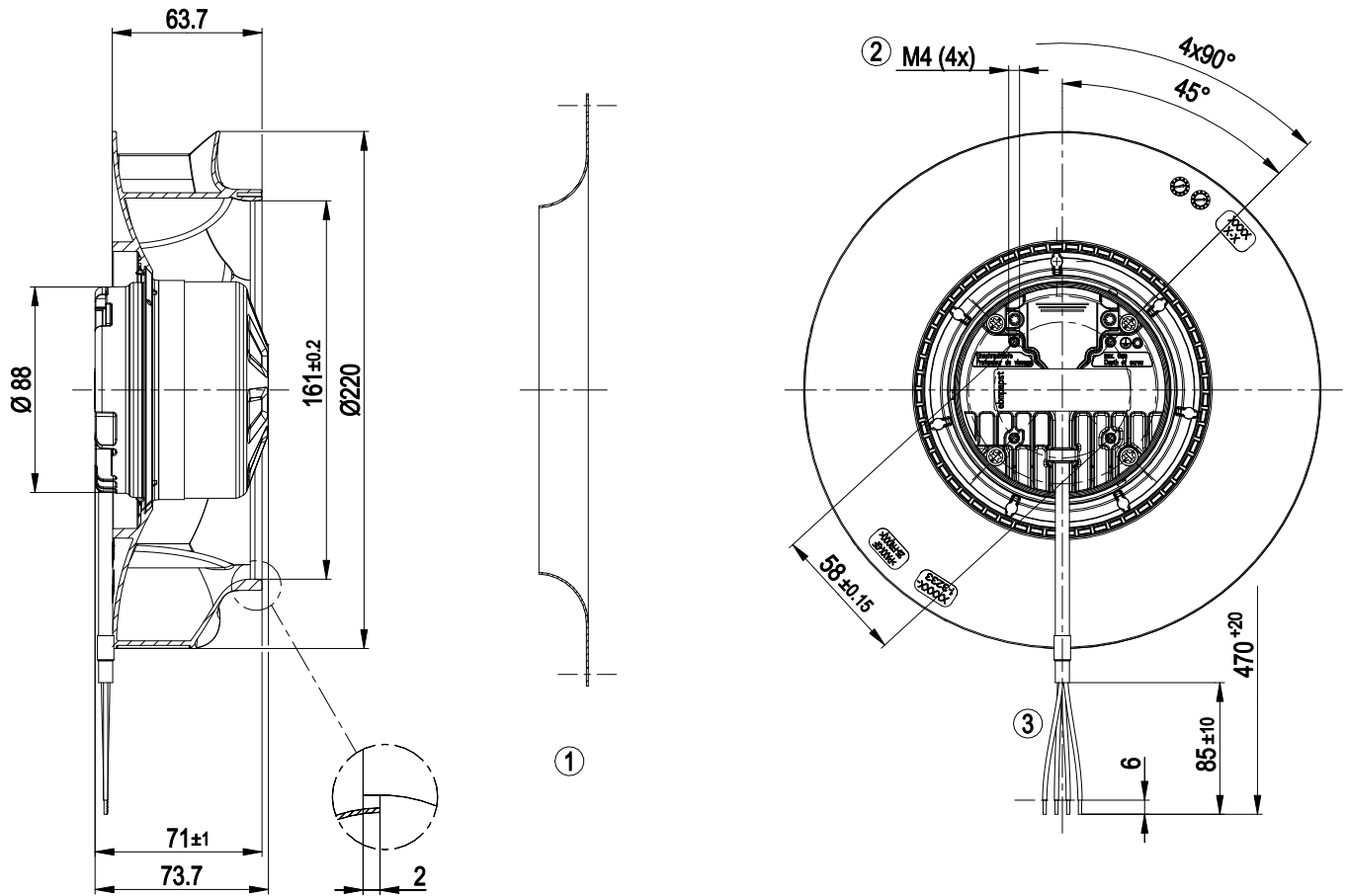

- | | |
|---|---|
| 1 | Accessory part: Inlet nozzle 09609-2-4013 not included in scope of delivery |
| 2 | Thread reach max. 6 mm |
| 3 | Connection line FLRYW 4x 0.75 mm ² , 4x lead tip crimped |



EC centrifugal fan - RadiCal

backward curved, single inlet

Automotive

Accessory part

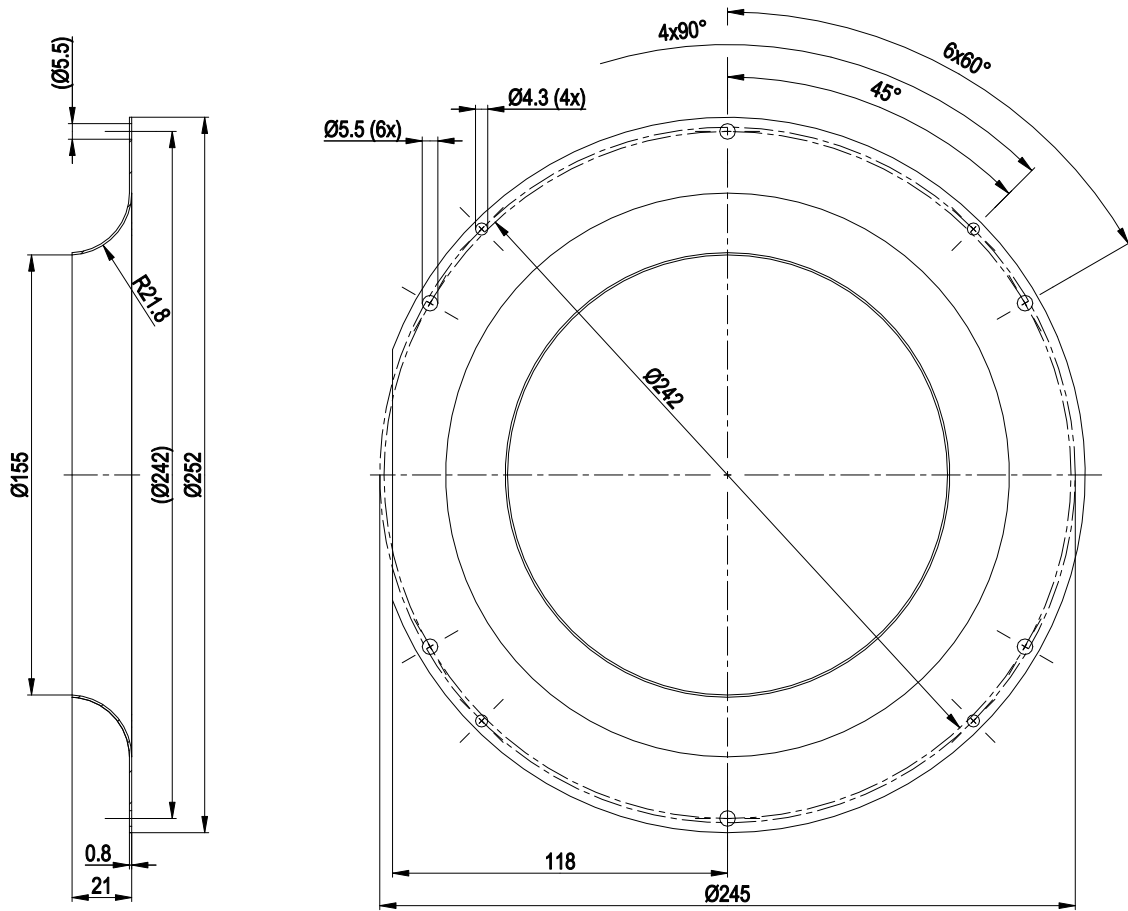

EC centrifugal fan - RadiCal

backward curved, single inlet

Automotive

Connection screen

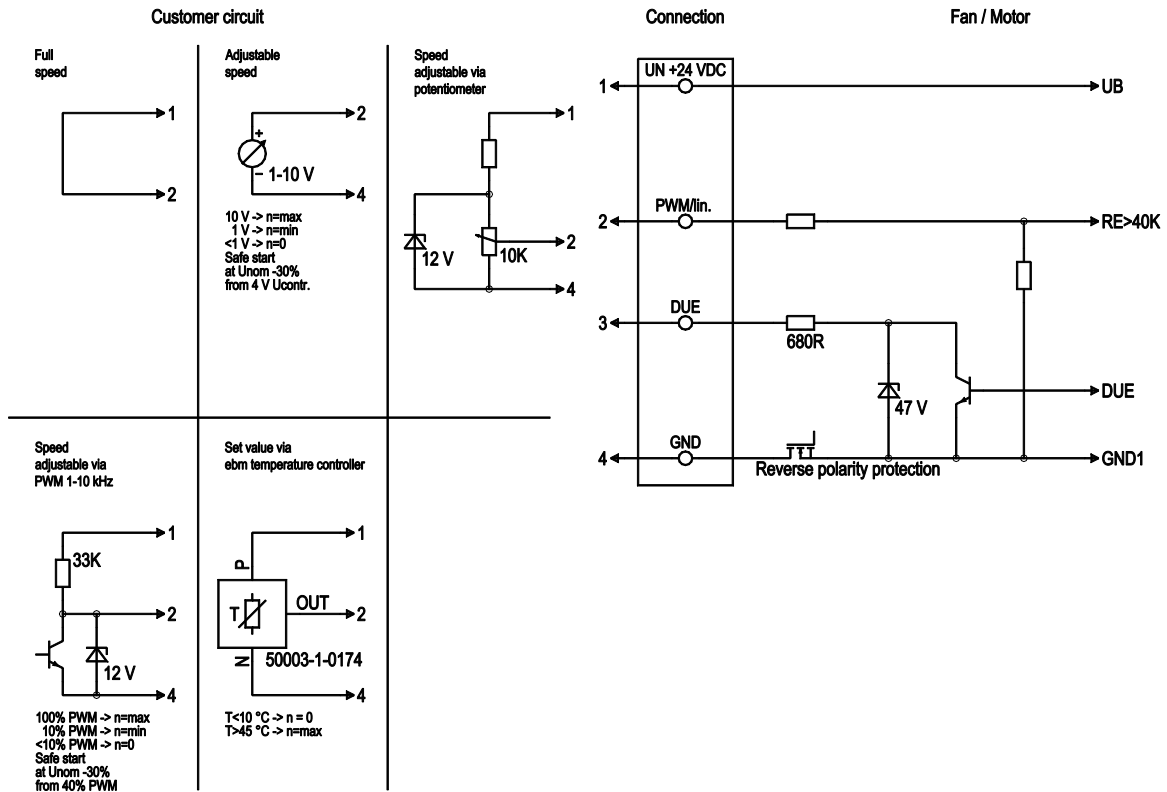

No.	Conn.	Designation	Colour	Function / assignment
	1	UN +24 VDC	red	Power supply 24 VDC, maximum ripple 3.5 %
	2	PWM/LIN	yellow	Control input Re > 40k
	3	DUE	white	Speed monitoring output, 3 pulses per revolution, Isink max = 10 mA
	4	GND	blue	Reference earth



EC centrifugal fan - RadiCal

backward curved, single inlet

Automotive

Charts: Air flow

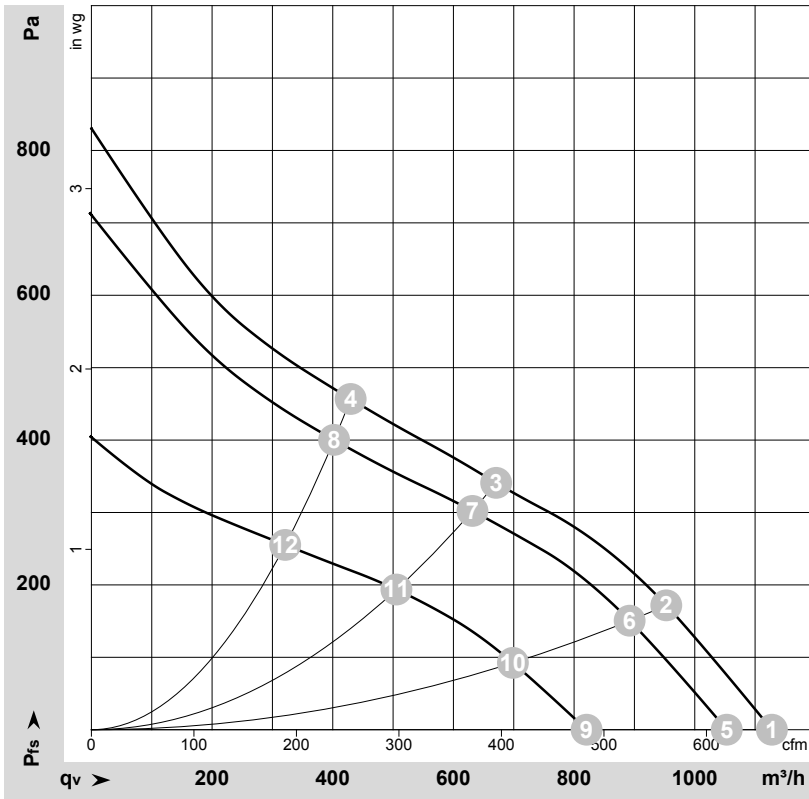

$\rho = 1.15 \text{ kg/m}^3 \pm 2 \%$

Measurement: LU-175803-1
 Measurement: LU-175755-1
 Measurement: LU-175801-1

Air performance measured as per ISO 5801 Installation category A. For detailed information on the measuring set-up, please contact ebm-papst. Suction-side noise levels: LwA measured as per ISO 13347 / LpA measured with 1m distance to fan axis. The values given are valid under the measuring conditions mentioned above and may vary according to the actual installation situation. With any deviation from the standard set-up, the specific values have to be checked and reviewed with the unit installed.

Measured values

	U	n	P _{ed}	I	LpA _{in}	LwA _{in}	q _v	P _{fs}	q _v	P _{fs}
	V	min ⁻¹	W	A	dB(A)	dB(A)	m ³ /h	Pa	cfm	in. wg
1	28	3225	139	7.05			1130	0	665	0.00
2	28	3125	141	7.29			955	172	560	0.69
3	28	3025	145	7.64			670	341	395	1.37
4	28	3105	142	7.37			430	457	255	1.83
5	24	3030	112	6.30	69	77	1055	0	620	0.00
6	24	2935	115	6.52	66	74	890	150	525	0.60
7	24	2840	117	6.78	61	69	630	300	370	1.20
8	24	2920	115	6.56	63	71	400	400	235	1.61
9	16	2390	56	4.39			820	0	485	0.00
10	16	2350	58	4.56			700	92	410	0.37
11	16	2300	60	4.78			505	194	300	0.78
12	16	2340	58	4.60			320	255	190	1.02

U = Supply voltage · n = Speed (rpm) · P_{ed} = Power input · I = Current draw · LpA_{in} = Sound pressure level inlet side · LwA_{in} = Sound power level inlet side · q_v = Air flow · p_{fs} = Pressure increase

