

M4Q045-EF01-01 ebmpapst Datasheet
 sales@fansco.com
 www.fansco.com

Nominal data

Type	M4Q045-EF01-01		
Motor	M4Q045-EF		
Phase		1~	1~
Nominal voltage	VAC	230	230
Frequency	Hz	50	60
Method of obtaining data		me	me
Valid for approval/standard		CE	CE
Speed	min ⁻¹	1300	1550
Power consumption	W	110	100
Power output	W	34	34
Current draw	A	0.75	0.65
Min. ambient temperature	°C	-30	-30
Max. ambient temperature	°C	40	40
Starting current	A	1.2	0.95

ml = Max. load · me = Max. efficiency · fa = Free air · cs = Customer specification · ce = Customer equipment
 Subject to change



Technical description

Weight	2.2 kg
Fan size	45 mm
Bearing shield material	Die-cast aluminum
Direction of rotation	Counterclockwise, viewed toward rotor
Degree of protection	IP42; installation- and position-dependent
Insulation class	"B"
Max. permitted ambient temp. for motor (transport/storage)	+ 80 °C
Min. permitted ambient temp. for motor (transport/storage)	- 40 °C
Installation position	Any, preferably horizontal
Condensation drainage holes	None
Mode	S1
Motor bearing	Calotte bearing
Touch current according to IEC 60990 (measuring circuit Fig. 4, TN system)	< 0.75 mA
Motor protection	Thermal overload protector (TOP) internally connected
With cable	Lateral
Protection class	I (with customer connection of protective earth)
Conformity with standards	EN 60335-1; CE
Approval	EAC; VDE

Product drawing

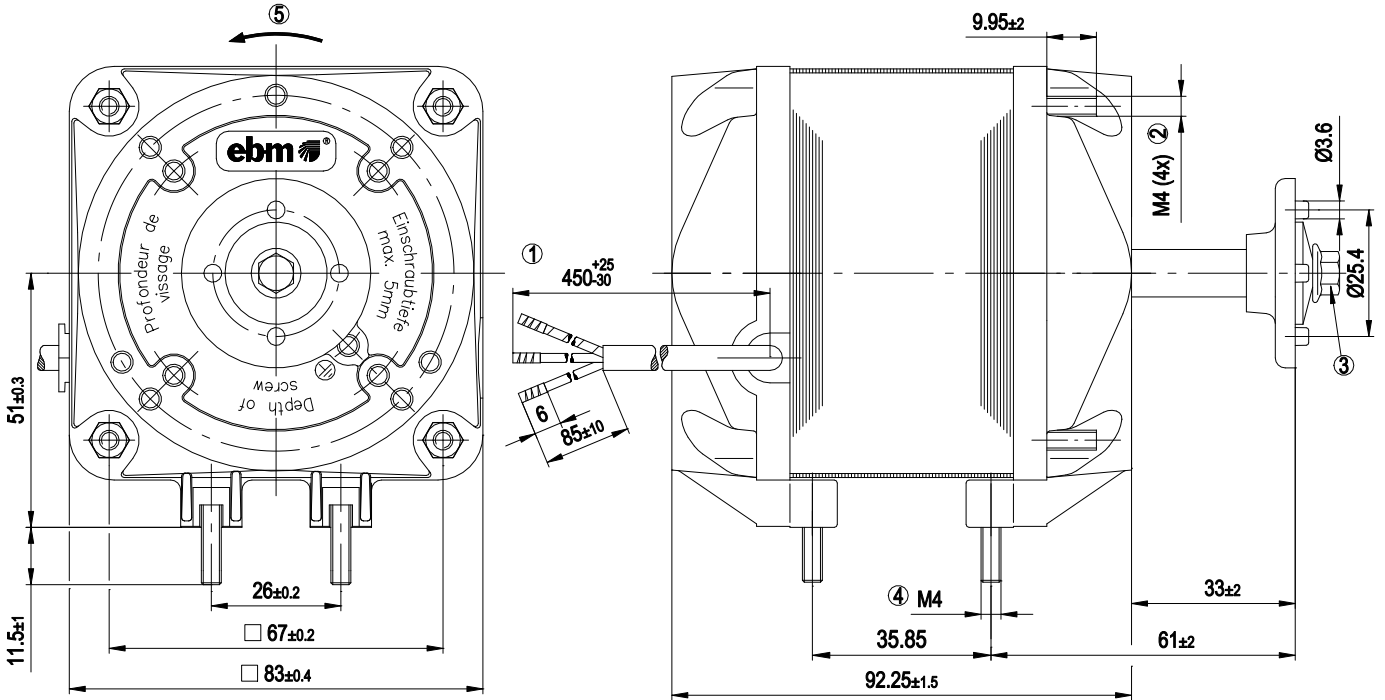

1	Cable PVC 3G 0.5mm ² , 3x crimped splices
2	Tightening torque for nuts to fasten fan housing or guard grille: 2.3 Nm
3	Tightening torque for screw to fasten fan impeller: 1.4 Nm
4	Tightening torque for nuts to fasten mounting bracket: 2.3 Nm
5	Direction of rotation counterclockwise, viewed toward shaft end

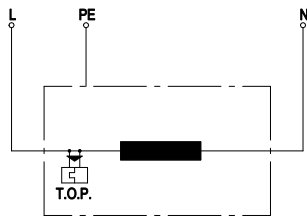

Connection diagram

L	= blue
PE	= green/yellow
N	= brown
TOP	= thermal overload protector

Curves: Speed

