

M4Q045-EA01-75 ebmpapst Datasheet

sales@fansco.com

www.fansco.com

Nominal data

Type	M4Q045-EA01-75		
Motor	M4Q045-EA		
Phase		1~	1~
Nominal voltage	VAC	230	230
Frequency	Hz	50	60
Method of obtaining data		me	me
Valid for approval/standard		CE	CE
Speed (rpm)	min ⁻¹	1300	1550
Power consumption	W	90	80
Power output	W	25	26
Current draw	A	0.62	0.55
Rated torque	Ncm	18.5	16
Mean starting torque	Ncm	8.5	6.5
Min. ambient temperature	°C	-30	-30
Max. ambient temperature	°C	40	40

ml = Max. load · me = Max. efficiency · fa = Free air · cs = Customer specification · ce = Customer equipment
 Subject to change



Technical description

Weight	2 kg
Fan size	45 mm
Bearing shield material	Die-cast aluminum
Direction of rotation	Counterclockwise, viewed toward rotor
Degree of protection	IP20
Insulation class	"B"
Max. permitted ambient temp. for motor (transport/storage)	+ 80 °C
Min. permitted ambient temp. for motor (transport/storage)	- 40 °C
Installation position	Any, preferably horizontal
Condensation drainage holes	None
Mode	S1
Motor bearing	Calotte bearing
Touch current according to IEC 60990 (measuring circuit Fig. 4, TN system)	< 0.75 mA
Motor protection	Thermal overload protector (TOP) internally connected
With cable	Lateral
Protection class	I (with customer connection of protective earth)
Conformity with standards	EN 60335-1; CE
Approval	VDE; EAC

Product drawing

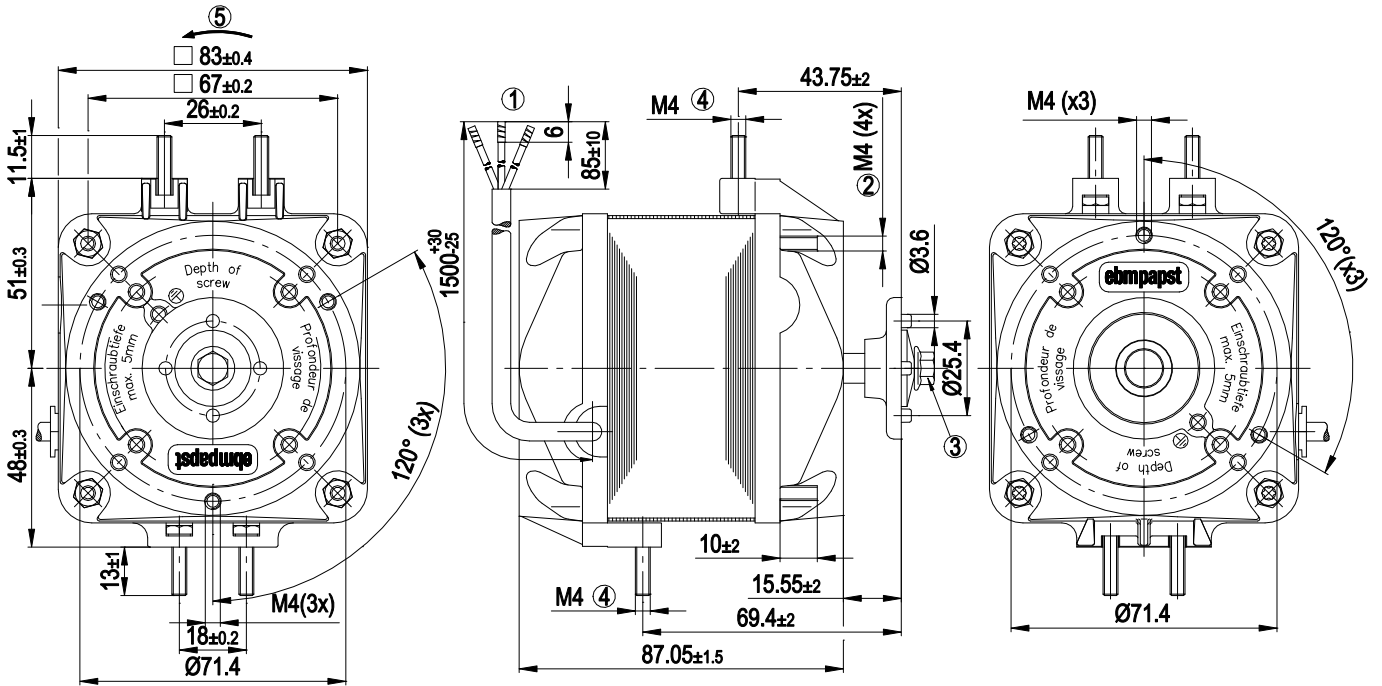

1	Cable PVC 3G 0.5 mm ² , 3x crimped splices
2	Tightening torque for nut for fastening fan housing or guard grille 2.3 Nm
3	Tightening torque for screw for fastening fan impeller 1.4 Nm
4	Tightening torque for nut for fastening mounting bracket 2.3 Nm
5	Direction of rotation counterclockwise, viewed toward shaft end

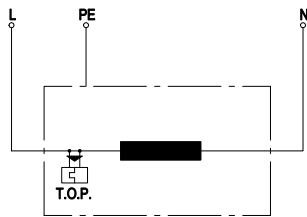

Connection diagram

L	= blue
PE	= green/yellow
N	= brown
TOP	= thermal overload protector

Curves: Speed (rpm)

