

M4Q045-DA05-01 ebmpapst Datasheet
 sales@fansco.com
 www.fansco.com

Nominal data

Type	M4Q045-DA05-01		
Motor	M4Q045-DA		
Phase		1~	1~
Nominal voltage	VAC	230	230
Frequency	Hz	50	60
Method of obtaining data		me	me
Valid for approval/standard		CE	CE
Speed (rpm)	min ⁻¹	1300	1550
Power consumption	W	86	80
Power output	W	23	25
Current draw	A	0.62	0.55
Min. ambient temperature	°C	-30	-30
Max. ambient temperature	°C	40	40
Starting current	A	0.9	0.8

ml = Max. load · me = Max. efficiency · fa = Free air · cs = Customer specification · ce = Customer equipment
 Subject to change



Technical description

Weight	1.53 kg
Fan size	45 mm
Bearing shield material	Die-cast aluminum
Direction of rotation	Counterclockwise, viewed toward rotor
Degree of protection	IP42
Insulation class	"B"
Max. permitted ambient temp. for motor (transport/storage)	+ 80 °C
Min. permitted ambient temp. for motor (transport/storage)	- 40 °C
Installation position	Shaft horizontal
Condensation drainage holes	None
Mode	S1
Motor bearing	Calotte bearing
Touch current according to IEC 60990 (measuring circuit Fig. 4, TN system)	< 0.75 mA
Motor protection	Thermal overload protector (TOP) internally connected
With cable	Lateral
Protection class	I (with customer connection of protective earth)
Conformity with standards	EN 60335-1; CE
Approval	EAC; VDE

Product drawing

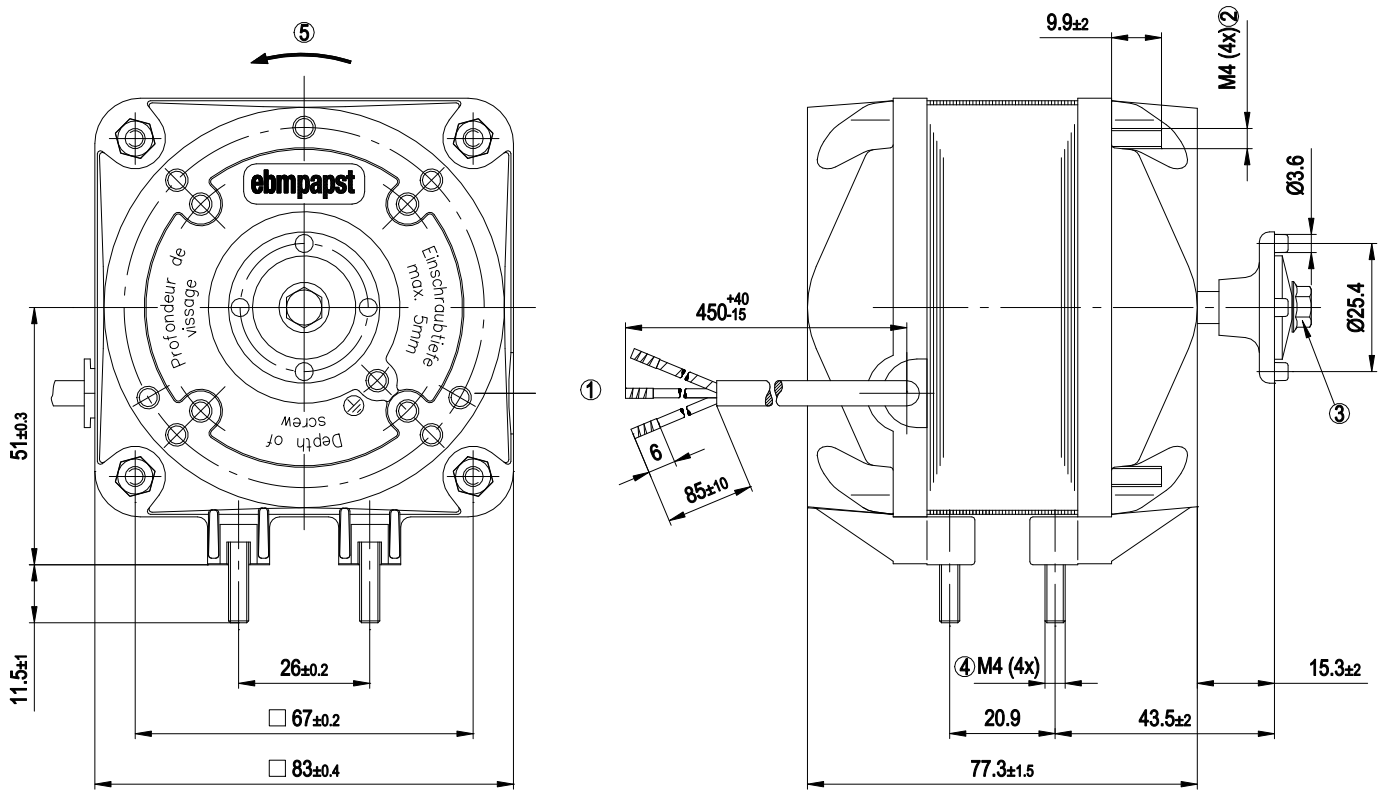

1	Cable PVC 3x 0.5 mm ² , 3x crimped splices
2	Tightening torque for nuts to fasten fan housing or guard grille: 2.3 Nm
3	Tightening torque for screw to fasten fan impeller: 1.4 Nm
4	Tightening torque for nuts to fasten mounting bracket: 2.3 Nm
5	Direction of rotation counterclockwise, viewed toward shaft end

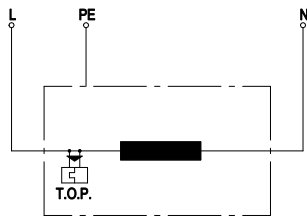

Connection diagram

L	= blue
PE	= green/yellow
N	= brown
TOP	= thermal overload protector

Curves: Speed (rpm)

