

M4Q045-CA27-E8 ebmpapst Datasheet
 sales@fansco.com
 www.fansco.com

Nominal data

Type	M4Q045-CA27-E8		
Motor	M4Q045-CA		
Phase		1~	1~
Nominal voltage	VAC	115	115
Frequency	Hz	50	60
Type of data definition		me	me
Valid for approval / standard		CE	CE
Speed	min ⁻¹	1300	1550
Power input	W	36	34
Power output	W	10	9
Current draw	A	0.5	0.45
Min. ambient temperature	°C	-30	-30
Max. ambient temperature	°C	40	40
Starting current	A	0.61	0.55

ml = max. load · me = max. efficiency · fa = running at free air · cs = customer specs · cu = customer unit
 Subject to alterations



Technical features

Size	45 mm
Material of end shield	Die-cast aluminium
Direction of rotation	Counter-clockwise, seen on rotor
Type of protection	IP 42; Depending on installation and position
Insulation class	"B"
Max. permissible ambient motor temp. (transp./ storage)	+ 80 °C
Min. permissible ambient motor temp. (transp./storage)	- 40 °C
Mounting position	Any, horizontal preferred
Condensate discharge holes	None
Operation mode	S1
Motor bearing	Calotte bearing
Touch current acc. IEC 60990 (measuring network Fig. 4, TN system)	< 0.75 mA
Motor protection	Impedance protected
Cable exit	Lateral
Protection class	I (if protective earth is connected by customer)
Product conforming to standard	CE
Approval	UL 2111; CSA C22.2 Nr.77

Product drawing

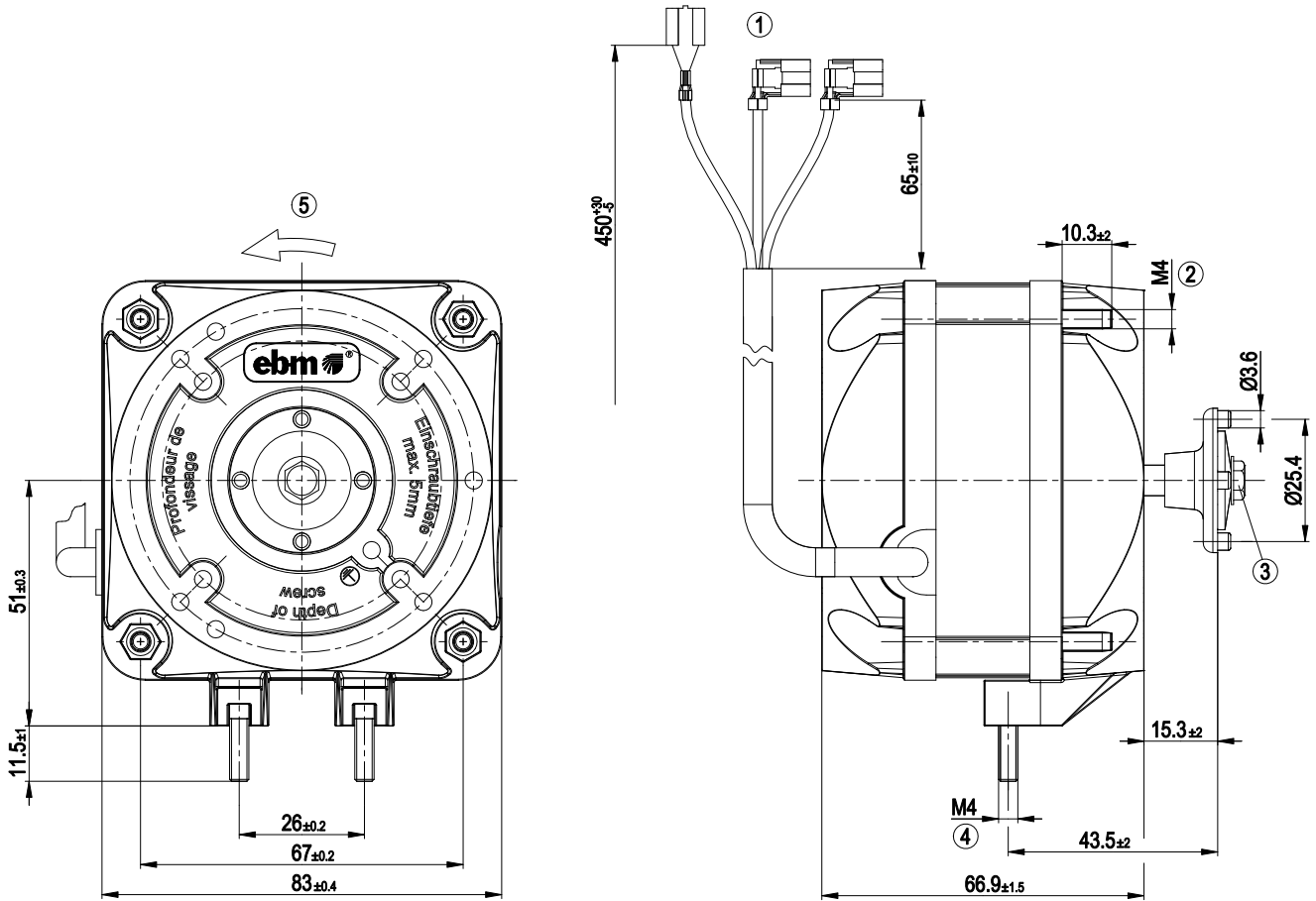

1	Connection line PVC 3G 0.5 mm ² , 1x receptacle for tabs 6.3x0.8 and 2x receptacle for tabs AMP 62718-2 crimped
2	Nut tightening torque, for fastening the wall ring or guard grille: 2.3 Nm
3	Screw tightening torque, for fastening the impeller: 1.4 Nm
4	Nut tightening torque, for fastening the mounting bracket: 2.3 Nm
5	Direction of rotation counter-clockwise, seen on shaft end

Connection screen

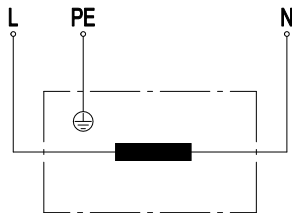

L	blue	PE	green/yellow	N	brown
---	------	----	--------------	---	-------



Charts: Speed

