

M4Q045-CA03-08 ebmpapst Datasheet
 sales@fansco.com
 www.fansco.com

Limited partnership · Headquarters Muldingen
 Amtsgericht (court of registration) Stuttgart · HRA 590344
 General partner Elektrobau Muldingen GmbH · Headquarters Muldingen
 Amtsgericht (court of registration) Stuttgart · HRB 590142

Nominal data

Type	M4Q045-CA03-08		
Motor	M4Q045-CA		
Phase		1~	1~
Nominal voltage	VAC	230	230
Frequency	Hz	50	60
Method of obtaining data		me	me
Valid for approval/standard		CE	CE
Speed (rpm)	min ⁻¹	1300	1550
Power consumption	W	36	34
Power output	W	10	9
Current draw	A	0.25	0.22
Min. ambient temperature	°C	-30	-30
Max. ambient temperature	°C	40	40
Starting current	A	0.33	0.3

ml = Max. load · me = Max. efficiency · fa = Free air · cs = Customer specification · ce = Customer equipment
 Subject to change



Technical description

Weight	1.1 kg
Fan size	45 mm
Direction of rotation	Counterclockwise, viewed toward rotor
Degree of protection	IP42; installation- and position-dependent
Insulation class	"B"
Max. permitted ambient temp. for motor (transport/storage)	+ 80 °C
Min. permitted ambient temp. for motor (transport/storage)	- 40 °C
Installation position	Any
Condensation drainage holes	None
Mode	S1
Motor bearing	Calotte bearing
Touch current according to IEC 60990 (measuring circuit Fig. 4, TN system)	< 0.75 mA
Electrical hookup	With plug
Motor protection	Impedance protection
Protection class	I (with customer connection of protective earth)
Conformity with standards	EN 60335-1; CE
Approval	VDE; EAC



Product drawing

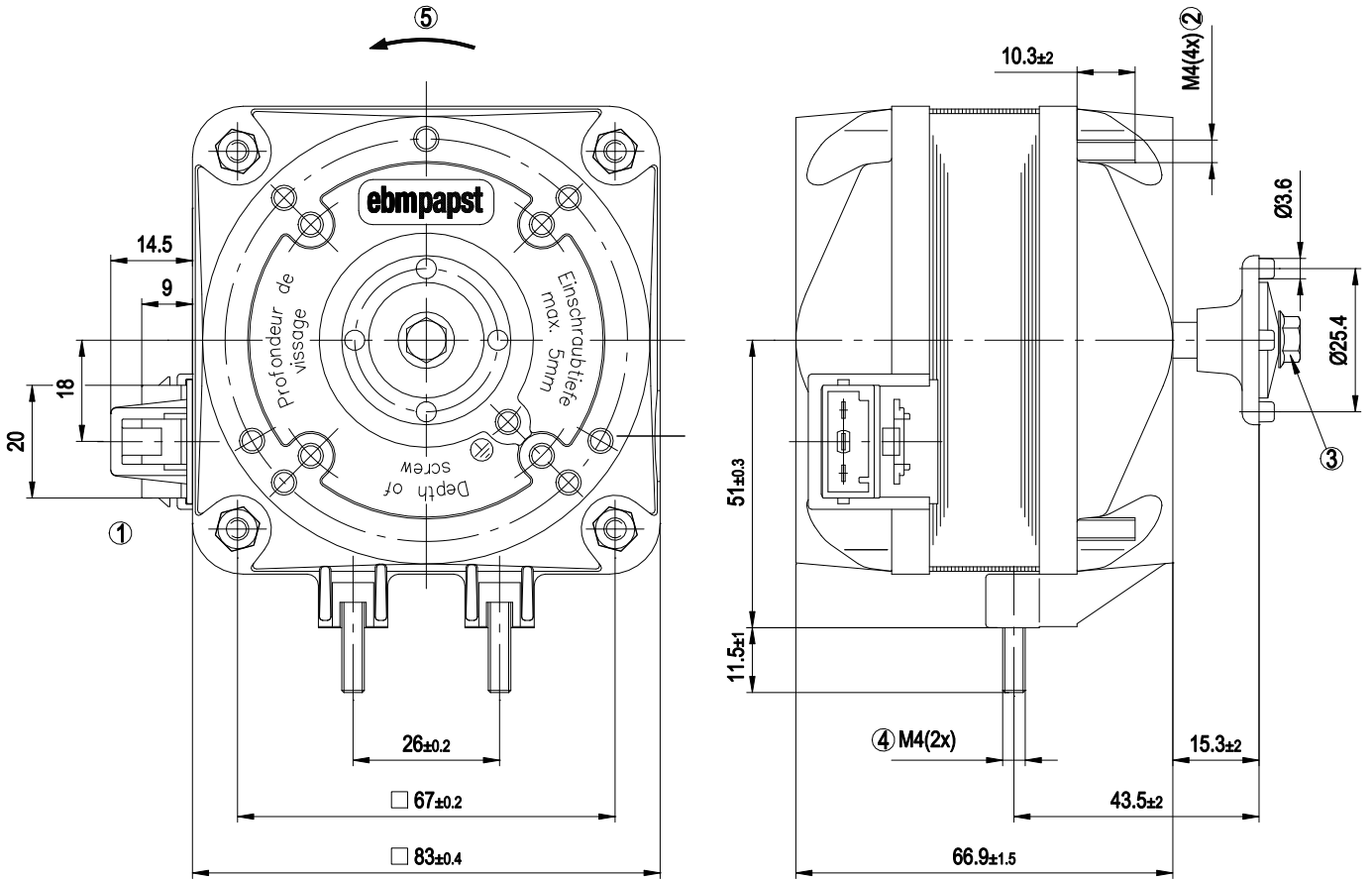

1	As stipulated by VDE, start up motor with ebmpapst cable only!
2	Tightening torque for nut for fastening fan housing or guard grille 2.3 Nm
3	Tightening torque for screw for fastening fan impeller 1.4 Nm
4	Tightening torque for nut for fastening mounting bracket 2.3 Nm
5	Direction of rotation counterclockwise, viewed toward shaft end

Connection diagram

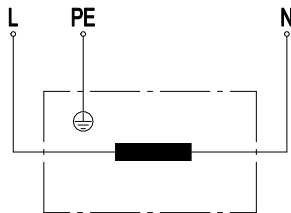

L	blue	PE	green/yellow	N	brown
---	------	----	--------------	---	-------



Curves: Speed (rpm)

