

M4Q045-CA01-G1 ebmpapst Datasheet

sales@fansco.com

www.fansco.com

Limited partnership · Headquarters Muldingen

Amtsgericht (court of registration) Stuttgart · HRA 590344

General partner Elektrobau Muldingen GmbH · Headquarters Muldingen

Amtsgericht (court of registration) Stuttgart · HRB 590142

Nominal data

Type	M4Q045-CA01-G1		
Motor	M4Q045-CA		
Phase		1~	1~
Nominal voltage	VAC	230	230
Frequency	Hz	50	60
Method of obtaining data		me	me
Valid for approval/standard		CE	CE
Speed (rpm)	min ⁻¹	1300	1550
Power consumption	W	31	30
Power output	W	7	8
Current draw	A	0.2	0.2
Max. ambient temperature	°C	40	40
Starting current	A	0.28	0.26

ml = Max. load · me = Max. efficiency · fa = Free air · cs = Customer specification · ce = Customer equipment
Subject to change



Technical description

Weight	1.07 kg
Fan size	45 mm
Bearing shield material	Die-cast aluminum
Direction of rotation	Counterclockwise, viewed toward rotor
Degree of protection	IP42; installation- and position-dependent
Insulation class	"B"
Max. permitted ambient temp. for motor (transport/storage)	+ 80 °C
Min. permitted ambient temp. for motor (transport/storage)	- 40 °C
Installation position	Shaft horizontal
Condensation drainage holes	None
Mode	S1
Motor bearing	Calotte bearing
Touch current according to IEC 60990 (measuring circuit Fig. 4, TN system)	< 0.75 mA
Motor protection	Impedance protection
With cable	Lateral
Protection class	I (additional protective earth terminal on motor housing (bearing shield) required)
Conformity with standards	EN 60335-1; CE



Product drawing

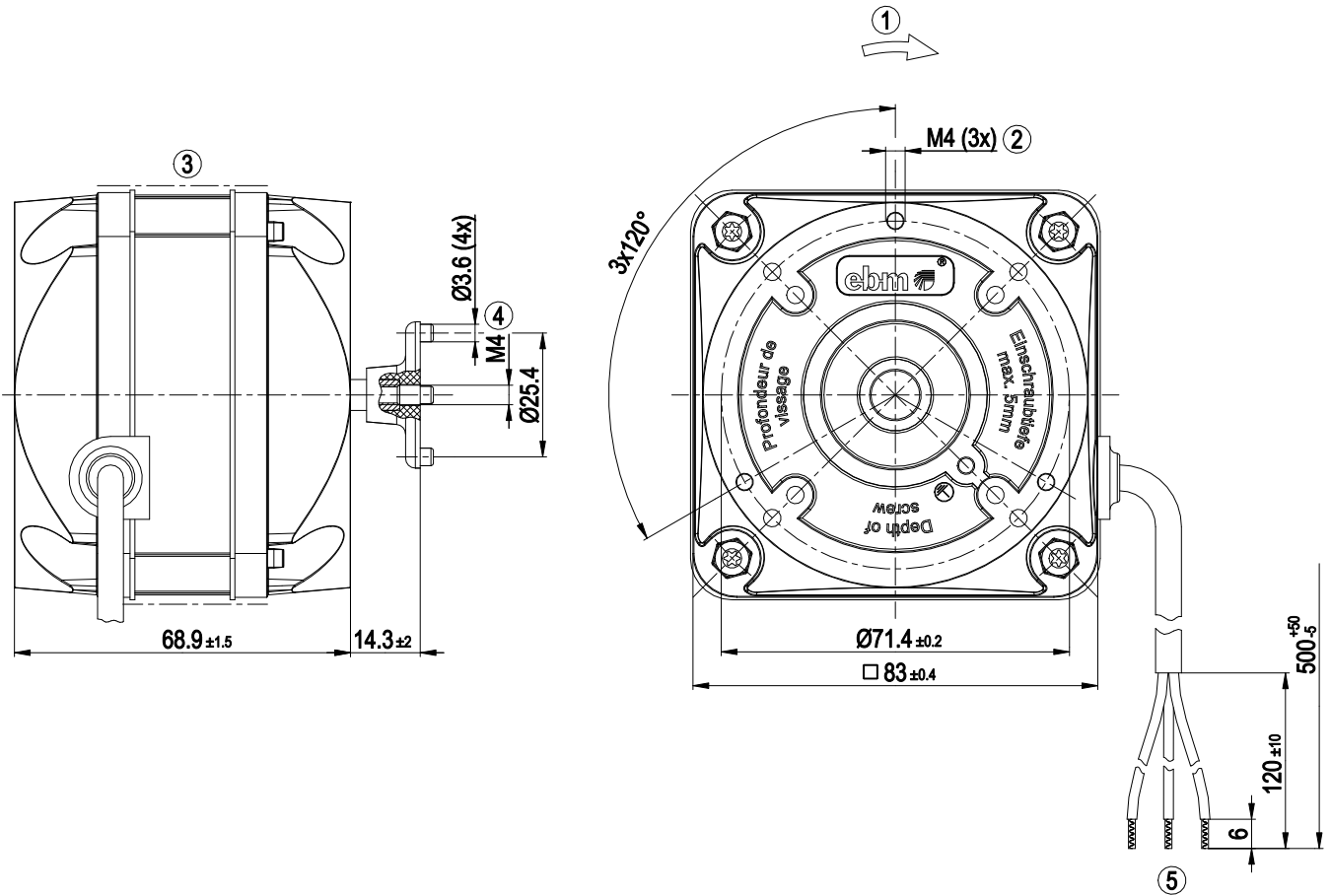

1	Direction of rotation counterclockwise, viewed toward shaft end
2	Max. clearance for screw 5 mm
3	Motor painted with finishing varnish in this area
4	Tightening torque for screw to fasten fan impeller: 1.4 Nm
5	Cable PVC 3G 0.5 mm ² , 3x crimped splices
	Additional protective earth terminal required on motor housing (bearing shield)



Connection diagram

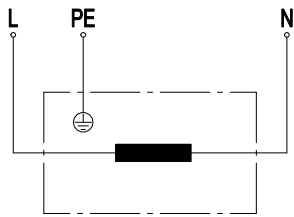

L	blue	PE	green/yellow	N	brown
---	------	----	--------------	---	-------



Curves: Speed (rpm)

