

M4Q045-BD03-04 ebmpapst Datasheet  
 sales@fansco.com  
 www.fansco.com

Limited partnership · Headquarters Muldingen  
 Amtsgericht (court of registration) Stuttgart · HRA 590344  
 General partner Elektrobau Muldingen GmbH · Headquarters Muldingen  
 Amtsgericht (court of registration) Stuttgart · HRB 590142

## Nominal data

Type	M4Q045-BD03-04		
Motor	M4Q045-BD		
Phase		1~	1~
Nominal voltage	VAC	115	115
Frequency	Hz	50	60
Method of obtaining data		me	me
Valid for approval/standard		CE	CE
Speed (rpm)	min <sup>-1</sup>	1300	1550
Power consumption	W	29	26
Power output	W	5	5
Current draw	A	0.38	0.35
Rated torque	Ncm	3	3
Mean starting torque	Ncm	2.3	1.8
Min. ambient temperature	°C	-30	-30
Max. ambient temperature	°C	40	40
Starting current	A	0.45	0.4

ml = Max. load · me = Max. efficiency · fa = Free air · cs = Customer specification · ce = Customer equipment  
 Subject to change



### Technical description

Weight	0.85 kg
Fan size	45 mm
Bearing shield material	Die-cast aluminum
Direction of rotation	Counterclockwise, viewed toward rotor
Degree of protection	IP42; installation- and position-dependent
Insulation class	"B"
Max. permitted ambient temp. for motor (transport/storage)	+ 80 °C
Min. permitted ambient temp. for motor (transport/storage)	- 40 °C
Installation position	Shaft horizontal
Condensation drainage holes	None
Mode	S1
Motor bearing	Calotte bearing
Touch current according to IEC 60990 (measuring circuit Fig. 4, TN system)	< 0.75 mA
Motor protection	Impedance protection
With cable	Lateral
Protection class	I (with customer connection of protective earth)
Conformity with standards	EN 60335-1; CE
Approval	UL 1004-2; EAC; CSA C22.2 No. 77



Product drawing

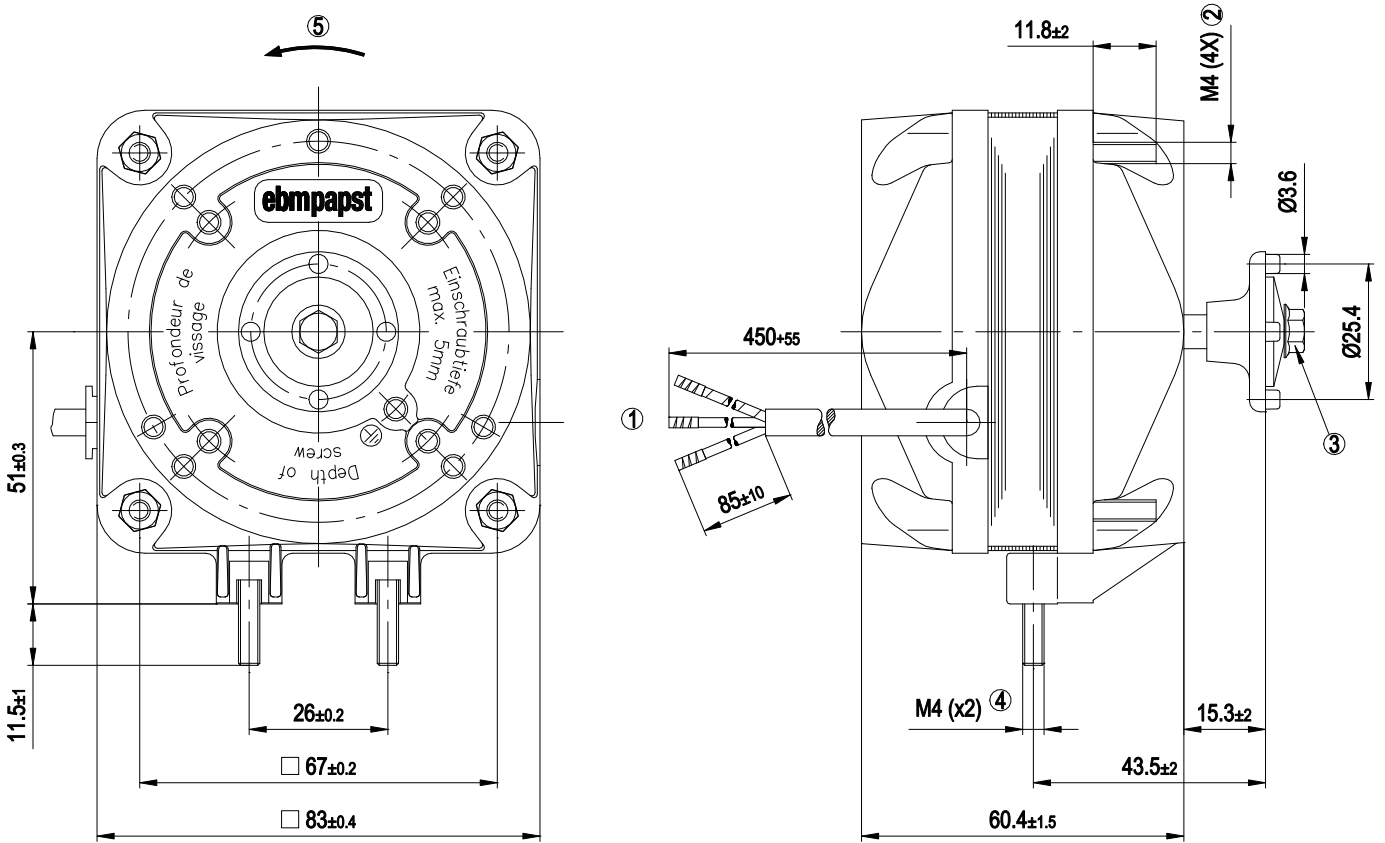

1	Cable PVC 3G AWG20, 3x crimped splices
2	Tightening torque for nuts to fasten fan housing or guard grille: 2.3 Nm
3	Tightening torque for screw to fasten fan impeller: 1.4 Nm
4	Tightening torque for nuts to fasten mounting bracket: 2.3 Nm
5	Direction of rotation counterclockwise, viewed toward shaft end

Connection diagram

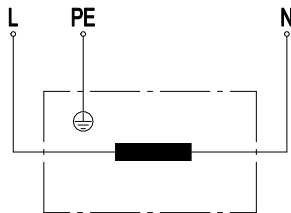

L	blue	PE	green/yellow	N	brown
---	------	----	--------------	---	-------



Curves: Speed (rpm)

