

M3G112-EA51-17 ebmpapst Datasheet
 sales@fansco.com
 www.fansco.com

Limited partnership · Headquarters Muldingen
 Amtsgericht (court of registration) Stuttgart · HRA 590344

General partner Elektrobau Muldingen GmbH · Headquarters Muldingen
 Amtsgericht (court of registration) Stuttgart · HRB 590142

Nominal data

Type	M3G112-EA51-17	
Motor	M3G112-EA	
Phase		1~
Nominal voltage range	VAC	200 .. 277
Frequency	Hz	50/60
Method of obtaining data		cs
Speed (rpm)	min ⁻¹	1150
Power consumption	W	376
Power output	W	340
Current draw	A	1.9 (230V)
Min. ambient temperature	°C	-25
Max. ambient temperature	°C	40

ml = Max. load · me = Max. efficiency · fa = Free air · cs = Customer specification · ce = Customer equipment
 Subject to change



Technical description

Weight	6 kg
Fan size	112 mm
Rotor surface	Painted black
Electronics housing material	PA plastic
Direction of rotation	Counterclockwise, viewed toward rotor
Degree of protection	IP20
Insulation class	"B"
Moisture (F) / Environmental (H) protection class	F4-1
Max. permitted ambient temp. for motor (transport/storage)	+ 80 °C
Min. permitted ambient temp. for motor (transport/storage)	- 40 °C
Installation position	Any
Condensation drainage holes	None
Mode	S1
Motor bearing	Ball bearing
Technical features	<ul style="list-style-type: none"> - Operation and alarm display: reversible voltage output 0 V / +15 V - Integrated PID controller - Motor current limitation - PFC, active - RS-485 ebmBUS - Soft start - Control interface with SELV potential safely disconnected from supply - Thermal overload protection for electronics/motor
EMC immunity to interference	According to EN 61000-6-2 (industrial environment)
EMC circuit feedback	According to EN 61000-3-2/3
EMC interference emission	According to EN 61000-6-4 (industrial environment)
Touch current according to IEC 60990 (measuring circuit Fig. 4, TN system)	<= 3.5 mA
Electrical hookup	With plug
Motor protection	Thermal overload protector (TOP) internally connected
With cable	Variable
Protection class	I (with customer connection of protective earth)
Conformity with standards	EN 61800-5-1
Approval	CCC; EAC



Connection diagram

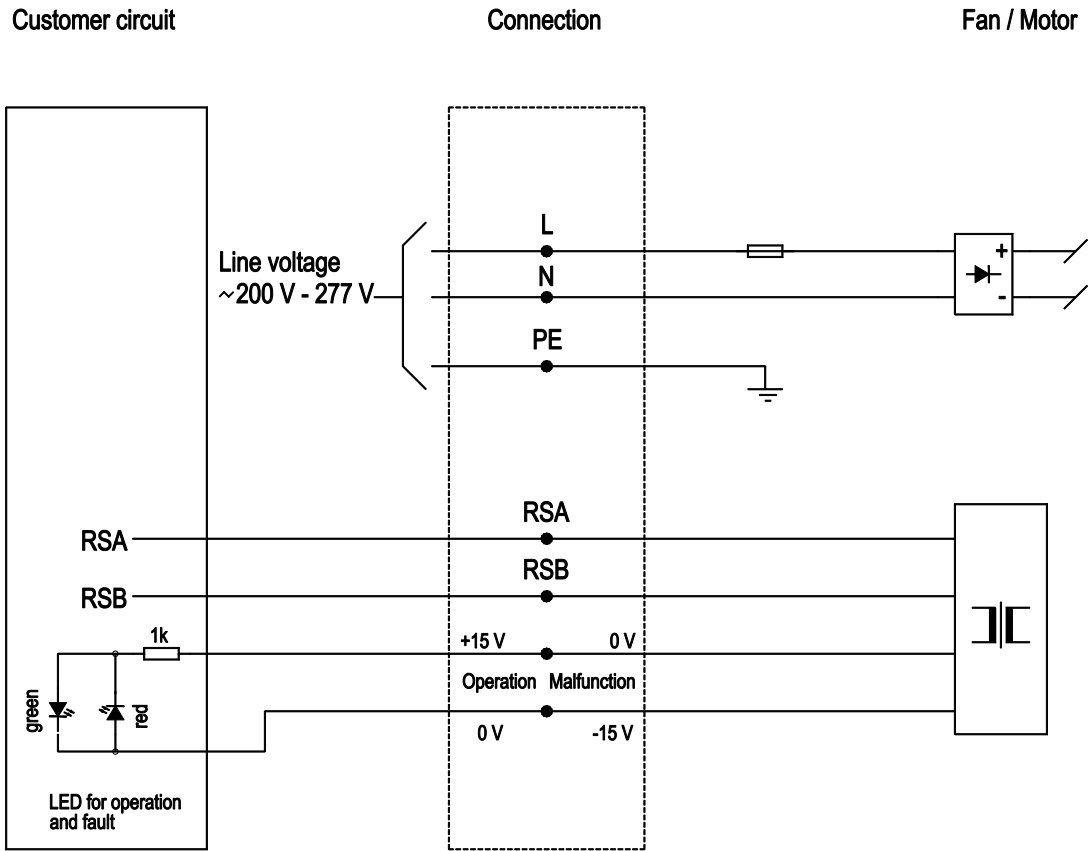

Curves: Speed (rpm)

